

Atmospheric Measurement Techniques Discussions is the access reviewed discussion forum of *Atmospheric Measurement Techniques*

TEOM and charging

N. K. Meyer et al.

Influence of particle charging on TEOM measurements in the presence of an electrostatic precipitator

N. K. Meyer¹, A. Lauber², T. Nussbaumer², and H. Burtscher¹

¹Institute for Aerosol and Sensor Technology, University of Applied Sciences, Windisch, Switzerland

²Bioenergy Research Group, University of Applied Sciences, Lucerne, Horw, Switzerland

Received: 12 September 2008 – Accepted: 27 October 2008 – Published: 8 December 2008

Correspondence to: N. K. Meyer (nicmeyer@yahoo.co.uk)

Published by Copernicus Publications on behalf of the European Geosciences Union.

Title Page

Abstract

Introduction

Conclusions

References

Tables

Figures

⏪

⏩

◀

▶

Back

Close

Full Screen / Esc

Printer-friendly Version

Interactive Discussion



Abstract

The efficiency of an electrostatic precipitator (ESP) for reducing wood combustion emissions was investigated. Real-time measurements were conducted by directly reading the change in frequency of the tapered element in a Thermo Scientific 1400a TEOM. The measurements have been shown to be influenced by the charge on the aerosols reaching the tapered element such that the TEOM overestimates mass concentration. This electrostatic effect was cross-checked with particle number concentration measurements where no influence was observed. Placing a radioactive neutraliser prior to the TEOM leads to agreement between observed ESP efficiencies as measured by both the TEOM and a CPC.

1 Introduction

Particulate emissions from domestic wood burning appliances can be reduced by placing an electrostatic precipitator (ESP) directly in the emission stack. An ESP generates corona ions which charge an aerosol, leading to forced electrophoretic deposition of the particles. The efficiency of an ESP is heavily dependant upon ion concentration, field strength between the active and grounding electrodes, temperature and stack velocity (residence time). Due to the transport mechanisms in the ESP, the precipitation is mainly influenced by the particle size, and also by particle morphology and composition. Measurement of efficiency is most readily determined by comparing samples collected while the filter is off and then on. A common method for this is the comparison of mass concentrations collected using heated gravimetric filters. Various international emission monitoring standards dictate that sampling of both ambient and combustion generated aerosols must be conducted via gravimetric analysis. This technique is both labour intensive and time consuming and subject to experimental error. Alternative methods for determination of mass concentration include the Tapered Element Oscillating Microbalance (TEOM), beta absorption and optical detection (Burtscher, 2005).

TEOM and charging

N. K. Meyer et al.

Title Page

Abstract

Introduction

Conclusions

References

Tables

Figures

⏪

⏩

◀

▶

Back

Close

Full Screen / Esc

Printer-friendly Version

Interactive Discussion



TEOM and charging

N. K. Meyer et al.

[Title Page](#)[Abstract](#)[Introduction](#)[Conclusions](#)[References](#)[Tables](#)[Figures](#)[◀](#)[▶](#)[◀](#)[▶](#)[Back](#)[Close](#)[Full Screen / Esc](#)[Printer-friendly Version](#)[Interactive Discussion](#)

UK monitoring network suggest that correction factors of approximately 1.3 should be used at ambient conditions. These correction factors are known to vary with location as source weightings vary between rural and urban regions (Green et al., 2001; Green and Fuller, 2006). Our investigations have shown that the TEOM is also influenced by the charge loading on the measured sample. When utilising electrostatic methods for measuring aerosols, for example with a Scanning Mobility Particle Sizer (SMPS), an aerosol neutralizer is used to bring about charge equilibrium. As the TEOM does not rely upon electrostatic characterisation of particle, use of a neutraliser is not prescribed. However, field analysis of the TEOM, gravimetric filter and a condensation particle counter (CPC) has indicated that the absence of a neutraliser in the sample train lead to an artificial overestimation of particle mass concentration when the ESP is on.

2 Experimental

Combustion emissions were generated using an automatic wood pellet boiler. The pellet boiler was chosen as the emission source because its operating parameters were well understood and its emissions well characterised. When operated under steady state combustion conditions its emissions were constant. It is known that the proportion of salts found in emissions from automatic wood boilers operated under ideal conditions is high whereas the organic fraction has been reported to be low when compared with emissions from a conventional log wood stove. Under ideal combustion conditions (Nussbaumer, 2003) particulate emissions consist of mainly inorganic matter (KCl, CaOH etc.) with organic carbon (OC) between 1 and 5%, while particles from incomplete combustion consist mainly of soot and organic carbon with small amounts of inorganic matter (Nussbaumer and Hasler, 1999; Oser et al., 2000; Klippel and Nussbaumer, 2006). This facet of the combustion emissions enabled observation of the electrostatic effect upon mass concentrations without the influence of losses attributed to the volatilisation of condensable materials typically observed when us-

TEOM and charging

N. K. Meyer et al.

Title Page

Abstract

Introduction

Conclusions

References

Tables

Figures

◀

▶

◀

▶

Back

Close

Full Screen / Esc

Printer-friendly Version

Interactive Discussion



TEOM and charging

N. K. Meyer et al.

ing log wood stoves. Monitoring of combustion gases and conditions was maintained throughout the experiments to ensure that steady state combustion conditions were maintained (i.e., excess air $\lambda=1.55$). A simplified experimental setup is depicted in Fig. 1. Emissions generated by the boiler pass into the emissions stack at a constant velocity (1 m/s). The ESP (built in-house) was situated a distance of two metres above the boiler and operated over a range of 12–14 kV. The sample was collected through an isokinetic probe having diameter of 14 mm and sample flow of 1 m/s; all results were normalised to 13% O₂. Raw concentrations observed in the emissions stack would saturate the TEOM and as such a dual stage heated ejector dilution unit is used to reduce observed concentrations (average dilution ~ 150). The first stage was heated to 150°C and supplied with heated, dry, hydrocarbon and particle free compressed air. The second stage dilution is supplied with the same air, albeit cold. A PM10 cyclone is used to separate out any larger fractions present. After dilution the sample is then passed to the TEOM and CPC (TSI-3025) either through the Kr85+ neutraliser (TSI, High flow, 3012) or an equivalent length of 10 mm stainless steel tube.

3 Results

3.1 TEOM measurement characteristics

To determine repeatability between the TEOM measurements three burn cycles were measured under ideal combustion conditions ($\lambda=1.55$) with the ESP off (Fig. 2). The results were normalised to 13% O₂ (Normalisation factor ~ 0.59) and in-stack concentrations were calculated using Eq. (1) where D is the dilution ratio (~ 150). The average sample time for each measurement was 25 min.

$$\left(\frac{\text{mg}}{\text{m}^3}\right)_{\text{In-Stack (normalised)}} = D \times \left(\frac{\text{mg}}{\text{m}^3}\right)_{\text{TEOM (normalised)}} \quad (1)$$

[Title Page](#)
[Abstract](#)
[Introduction](#)
[Conclusions](#)
[References](#)
[Tables](#)
[Figures](#)
[◀](#)
[▶](#)
[◀](#)
[▶](#)
[Back](#)
[Close](#)
[Full Screen / Esc](#)
[Printer-friendly Version](#)
[Interactive Discussion](#)

3.2 Influence of the ESP on TEOM measurements

To test the influence of the ESP on the TEOM measurements four different conditions were decided upon (summarised in Table 1). Average results and standard deviations from 6 tests under each conditions are presented (Fig. 3). Maximum emissions (when the ESP was off) are shown to be $\sim 16 \text{ mg/m}^3$. When the ESP was operating the particle concentration was measured to be $\sim 12.5 \text{ mg/m}^3$. Placing the neutraliser inline was observed to influence the measurements such that the measured mass concentration reduced to $\sim 2 \text{ mg/m}^3$. Given that the measurement characteristics of the TEOM are solely linked to mass accumulated on its collection substrate, this effect is both interesting and significant.

To determine whether the increase in mass observed in the absence of a neutraliser could be correlated with an increase in particle number concentration a CPC was positioned at the same measurement point as the TEOM. Results for this test can be seen in Fig. 4. The CPC number concentrations for both cases are shown in gray and the TEOM results in white. Number concentration as measured with the CPC remains constant whether the neutraliser is present or absent in the sample path. Mass concentration however, was observed to decrease when the neutraliser was placed inline, yet remain high in its absence. As a reference, total number concentrations measured when the ESP was off were an order of magnitude higher than those presented in Fig. 4. As such the particulate removal efficiency of the ESP as measured by both the TEOM and CPC was found to be $\sim 90\%$. The results in Fig. 4 suggest that the charge induced on an aerosol does lead to a substantial overestimation of mass measured by the TEOM.

4 Discussion

Given that the mass concentrations reported by the instrument are derived from the oscillating frequency of the tapered element further confirmation that the electrostatic

TEOM and charging

N. K. Meyer et al.

Title Page

Abstract

Introduction

Conclusions

References

Tables

Figures

⏪

⏩

◀

▶

Back

Close

Full Screen / Esc

Printer-friendly Version

Interactive Discussion



TEOM and charging

N. K. Meyer et al.

effect is a measurement artefact can be derived via analysis of change in operating frequency of the instrument. Duplicate results collected during a single sampling day are presented in Fig. 5. The measurement conditions presented refer to cases where the ESP is off, the ESP is on (without neutraliser) and the ESP is off (with neutraliser present). The differential of the frequency of the tapered element (df) reduces in this order according to the deposited mass. The case where the ESP is off shows the most negative gradient, this corresponds to the largest mass deposition, while the case where the ESP is on and the neutraliser present shows a gradient closest to zero, corresponding to the lowest mass deposited. Between these two lines lays the response of TEOM frequency to the particles charged by the ESP. The gradient of this line is ~ -10 times that observed for the neutralised particles and approximately half that of the maximum observed mass. This analysis indicates a force (which can be attributed to particle charge) is acting on the oscillator. The TEOM manual indicates that the tapered element is seated between opposing field electrodes while Baron and Willeke (2001) state that the element is coated in a conductive material so that oscillation can be induced in the glass element. It is unclear whether only a portion or the whole of the element is conductive. If the former is the case, it is possible that collected charge could contribute the observed reduction in oscillator frequency.

5 Conclusions

The influence of particle charging on TEOM measurements was investigated while conducting ESP efficiency tests on emissions from a domestic pellet boiler. Activating the ESP led to an increase in observed mass measured by the TEOM. This was inconsistent with values obtained during parallel TSP tests conducted using mass filter testing. This overestimation of mass by the TEOM was negated by placing a high flow neutraliser inline before the TEOM. Under optimal combustion conditions, ESP efficiency was found to be 94% when using the radioactive source and 55% when not. This variance is thought to be an artefact induced by the charge loading on the parti-

[Title Page](#)[Abstract](#)[Introduction](#)[Conclusions](#)[References](#)[Tables](#)[Figures](#)[◀](#)[▶](#)[◀](#)[▶](#)[Back](#)[Close](#)[Full Screen / Esc](#)[Printer-friendly Version](#)[Interactive Discussion](#)

cles and could be negated by placing an aerosol neutraliser inline prior to the TEOM. This electrostatic effect was confirmed to be an artefact by measuring particle number concentration with a CPC to confirm that no change in particle number concentration occurred in cases where charging was thought to influence the TEOM. Further analysis of the frequency read directly from the tapered element of the instrument indicates that some dampening of the oscillator is observed. Given the high number of in-use TEOM's in long-term monitoring programs worldwide, this effect demands further investigation.

References

- 10 Baron, P. A. and Willeke, K. (Eds.): *Aerosol Measurement: Principles, Techniques and Applications*, Wiley Interscience, 2001.
- Burtscher, H.: Physical characterization of particulate emissions from diesel engines: a review, *J. Aerosol Sci.*, 36(7), 896–932, 2005.
- EPA: Ambient Air Monitoring Reference and Equivalent Methods Designation, US Environmental Protection Agency, Federal Register, 55, 43 406–43 407, 1990.
- 15 Chen, J. and Davidson, J. H.: Model of the Negative DC Corona Plasma: Comparison to the Positive DC Corona Plasma, *Plasma Chem. Plasma Process.*, 23(1), 83–102, 2002.
- Green, D., Fuller, G., and Barratt, B.: Evaluation of the TEOM “correction factors” for assessing EU Stage 1 limit values for PM10, *Atmos. Environ.*, 35, 2589–2593, 2001.
- 20 Green, D. and Fuller, G. W.: The implications of tapered element oscillating microbalance (TEOM) software configuration on particulate matter measurements in the UK and Europe, *Atmos. Environ.*, 40, 5608–5616, 2006.
- Klippel, N. and Nussbaumer, T.: Feinstaubbildung in Holzfeuerungen und Gesundheitsrelevanz von Holzstaub im Vergleich zu Dieselruss, 9th Wood Energy Symposium, ETH, Zurich, Switzerland, 2006.
- 25 Nussbaumer, T.: Combustion and co-combustion of biomass: Fundamentals, technologies and primary measures for emission reduction, *Ener. Fuels*, 17, 1510–1521, 2003.
- Nussbaumer, T. and Hasler, P.: Bildung und Eigenschaften von Aerosolen aus Holzfeuerungen, *Holz als Roh- und Werkstoff*, 57, 13–22, 1999.

TEOM and charging

N. K. Meyer et al.

Title Page

Abstract

Introduction

Conclusions

References

Tables

Figures

◀

▶

◀

▶

Back

Close

Full Screen / Esc

Printer-friendly Version

Interactive Discussion



Oser, M., Nussbaumer, T., Schweizer, B., et al.: Untersuchung der Einflüsse auf die Partikelemissionen in einer Unterschubfeuerung, 6th Wood Energy Symposium, ETH, Zurich, 2000.

AMTD

1, 435–449, 2008

TEOM and charging

N. K. Meyer et al.

Title Page

Abstract

Introduction

Conclusions

References

Tables

Figures



Back

Close

Full Screen / Esc

Printer-friendly Version

Interactive Discussion



TEOM and charging

N. K. Meyer et al.

[Title Page](#)[Abstract](#)[Introduction](#)[Conclusions](#)[References](#)[Tables](#)[Figures](#)[Back](#)[Close](#)[Full Screen / Esc](#)[Printer-friendly Version](#)[Interactive Discussion](#)**Table 1.** Summary of test conditions used when measuring with the TEOM.

	ESP	Kr85 ⁺ Source
1. Off/no rad	off	bypass
2. Off/rad	off	inline
3. On/no rad	on	bypass
4. On/rad	on	inline

TEOM and charging

N. K. Meyer et al.

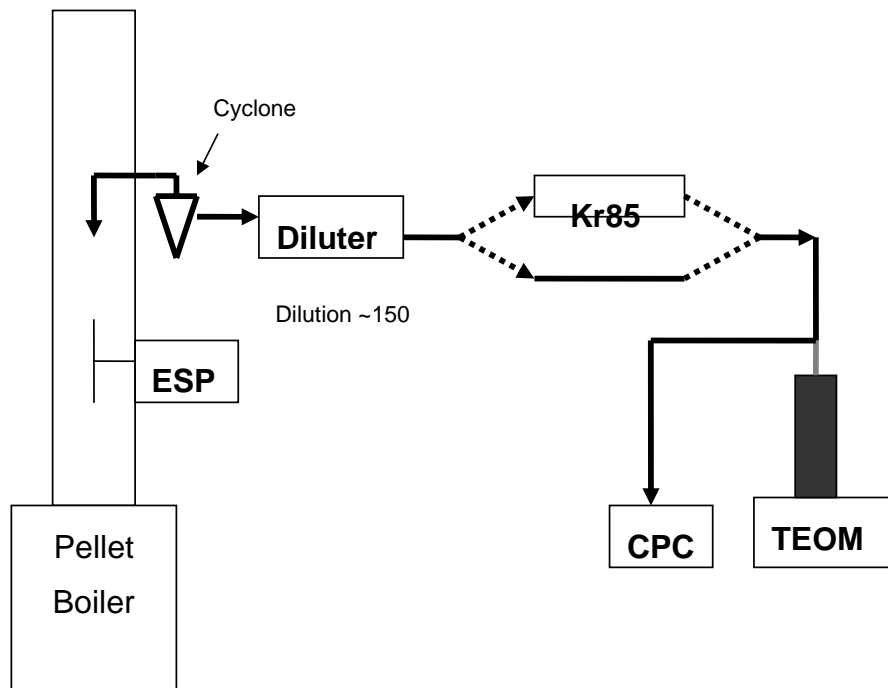

Fig. 1. Experimental setup.

[Title Page](#)[Abstract](#)[Introduction](#)[Conclusions](#)[References](#)[Tables](#)[Figures](#)[◀](#)[▶](#)[◀](#)[▶](#)[Back](#)[Close](#)[Full Screen / Esc](#)[Printer-friendly Version](#)[Interactive Discussion](#)

TEOM and charging

N. K. Meyer et al.

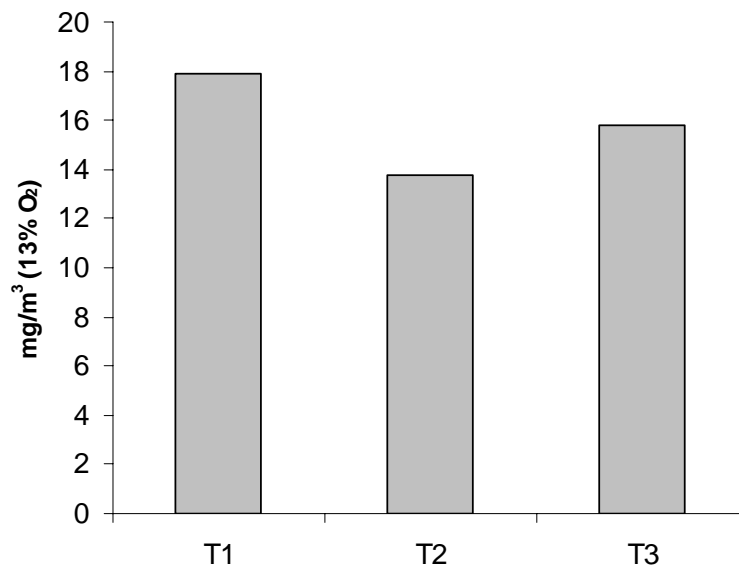

Fig. 2. Mass concentrations from a pellet boiler as measured by the TEOM with the ESP off. Each sample was collected over a period of ~25 min at a dilution ratio of ~150. The average mass concentration was ~16 mg/m³.

[Title Page](#)[Abstract](#)[Introduction](#)[Conclusions](#)[References](#)[Tables](#)[Figures](#)[◀](#)[▶](#)[◀](#)[▶](#)[Back](#)[Close](#)[Full Screen / Esc](#)[Printer-friendly Version](#)[Interactive Discussion](#)

TEOM and charging

N. K. Meyer et al.

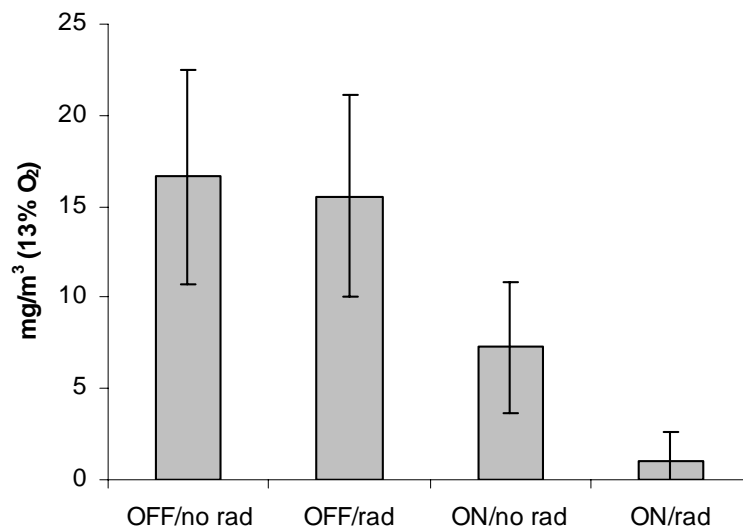

Fig. 3. Summary data – average TEOM results collected during measurements with the pellet boiler.

[Title Page](#)[Abstract](#)[Introduction](#)[Conclusions](#)[References](#)[Tables](#)[Figures](#)[◀](#)[▶](#)[◀](#)[▶](#)[Back](#)[Close](#)[Full Screen / Esc](#)[Printer-friendly Version](#)[Interactive Discussion](#)

TEOM and charging

N. K. Meyer et al.

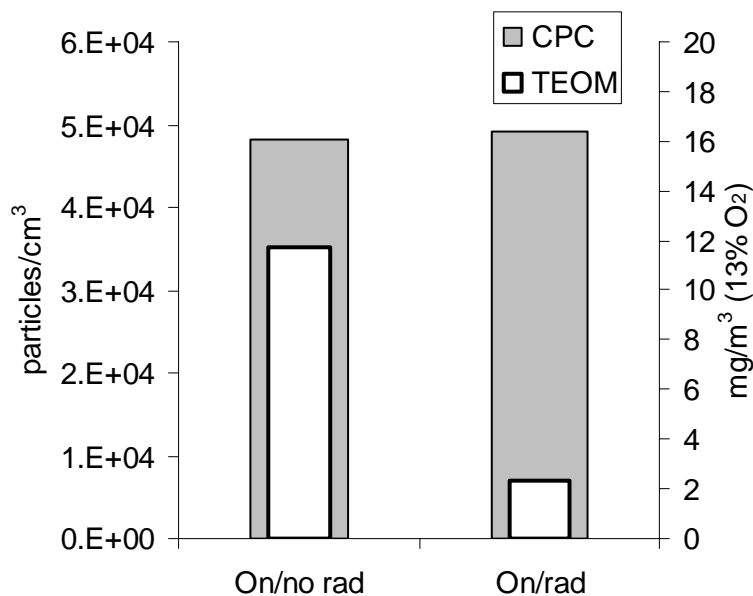

Fig. 4. Comparison of CPC and TEOM data when the Kr85+ source is either bypassed (On/no rad) or inline (On/rad).

[Title Page](#)[Abstract](#)[Introduction](#)[Conclusions](#)[References](#)[Tables](#)[Figures](#)[◀](#)[▶](#)[◀](#)[▶](#)[Back](#)[Close](#)[Full Screen / Esc](#)[Printer-friendly Version](#)[Interactive Discussion](#)

TEOM and charging

N. K. Meyer et al.

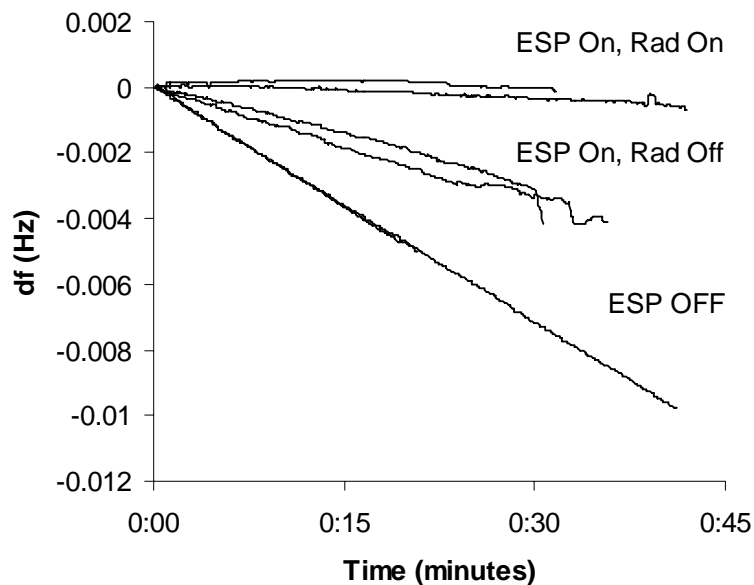

Fig. 5. Variation in tapered element frequency (df) during burn cycles. Larger reductions in frequency indicate larger deposited masses. Frequency reductions for three different conditions are shown.

[Title Page](#)[Abstract](#)[Introduction](#)[Conclusions](#)[References](#)[Tables](#)[Figures](#)[◀](#)[▶](#)[◀](#)[▶](#)[Back](#)[Close](#)[Full Screen / Esc](#)[Printer-friendly Version](#)[Interactive Discussion](#)