

Interactive comment on “Sub 3 nm particle size and composition dependent response of a nano-CPC battery” by J. Kangasluoma et al.

J. Kangasluoma et al.

juha.kangasluoma@helsinki.fi

Received and published: 10 January 2014

We want to thank the referees for critically reviewing the manuscript. We feel that the manuscript improved especially in terms of making the experimental setup clearer and hope that the manuscript is now ready for publication.

Anonymous Referee #1 Received and published: 9 December 2013 It is a great collaborative work. Authors effectively use the information on the molecular structure of the test particles to guide readers to understand the activation behavior of CPCs. Using the inorganic particles generated by a candle flame the authors provided a new view of understanding the difference in the particle-material dependence of the DEG and water based CPCs. It was especially enlightening that the authors indirectly showed

C3943

that lighter compounds are detected less effectively than heavier compounds although these two have the mobility diameter. This new observation may help explaining why the charger-generated ions are somehow detected poorly, or, may be implying that the sulfate ions in the lighter compounds are evaporating inside these CPCs. Authors successfully showed the variation in the activation behavior with respect to the particle material in this work. It is encouraged that authors investigate the variation with respect to inlet RH for a given particle material in their future study since the topic is more relevant when these CPCs are implemented during field campaigns.

<Specific Comments>

- Sampling flow rates at the inlet of each CPC needs to be added to Table 1. It is difficult to guess how the flow rates add to 8.1 L/min. Inlet flows added to table 1, the inlet flows of the CPCs add up to 6.1 lpm, the electrometer was operated with 2 lpm inlet flow to get total of 8.1 lpm.

- Authors mention that flow rates at the aerosol inlet and outlet was 6.1 L/min when Nano-DMA was used. Therefore, about 2.0 L/min needs to be aspirated at the DMA exit to have 8.1 L/min total flow rate for CPCs. The schematic shown in Figure 1 does not seem to be consistent with above flow setting since the schematic shows that the excess flow is always pushed out at the exit of the DMA. This was a mistake in the text, the DMA was operated with flow ratio 8.1:25, the aerosol flow was exactly the total inlet flow of the detectors.

- [Page 8863, Paragraph 5-12] It is recommended that authors show the size dependent transport efficiencies from the first separation point to the inlet of each CPCs. Then readers would be able to know the extent of correction applied to the each CPC at each size. It would be easier to see the difference if the transport efficiencies are shown in a form of a molded curve. Added figure 2 of penetration efficiencies.

- The reader would be interested in seeing the size dependent efficiency ratios between the DEG-CPC to PSM (or vice-versa) since the methods for creating the super-

C3944

saturated region is different between these two CPCs. Some scientists in this field may be questioning whether the different heating or cooling schemes used in these CPCs may induce the material dependence in activation behavior although the working fluids are the same. It may be difficult to see such effects since the aerosol particles in this study are well dried. To study the differences of DEG-CPC and PSM would need more in-depth characterization supersaturations by alternating instrument temperatures or flows, and preferably also by modeling, which are not done in this study. Additionally, the loss estimations in the present study may contain high uncertainties which might lead to wrong conclusions about the differences of the two methods. For these reasons we prefer not to study the differences here. However, we found that the DEG-CPC may have higher activation efficiency for the very smallest clusters, which we cannot show if it is due to smaller losses or higher local supersaturations. The DEG-CPC and the PSM are compared in Wimmer et al., (2013) AMT.

- It is not clear what the phrase "mixing state" is trying to infer. Is the mixing ratio given by Equation 1 is equivalent to the particle number concentration ratio of the aerosol particles? Our use of internal/external cluster mixtures refers only to whether or not the cluster population exists as a mixture of different single-component clusters (externally mixed) or as a mixture of multi-component clusters (internally mixed). The obtained mixing ratio is the exact equivalent of the ratio of the particle number concentrations if, and only if, we assume perfect (or equal) stability for all clusters, equal transmission for all clusters in the mass spec and equal diffusion losses in the lines for all clusters. This is not of course true, but it was the best we could do and the authors would be very interested to see the assumptions shown wrong.

- Authors are recommended to give the size range when they use the phrase "detects very poorly". Added to line 21 "to mention that sub 2 nm limonene ozonolysis" and to line 301 "concluded that DEG activates sub 2 nm organics very poorly" <Minor Comments>

- DMPS and NAIS should be spelled out once when they appear first time in the
C3945

paper. done

- Page 8866, Line 1, the word "interpret" is repeated twice corrected

- Figure 1. the sentence "setup to generate internally mixed sample" should be in the caption. done

- Figure 4. The caption should indicate which side corresponds to which polarity done

Anonymous Referee #2 Received and published: 9 December 2013 The manuscript "Sub 3 nm particle size and composition dependent response of a nano-CPC battery", by Kangasluoma and co-authors characterizes working fluid dependent counting efficiencies of various CPCs in the particle size range below 3 nm. To this end, the authors use all kinds of laboratory generated seed particles to test the response of three laminar flow CPCs and one turbulent mixing type CPC. Working fluids used included water, butanol and diethylen glycol (DEG). Emphasis was put on a comprehensive set of seeds representing most aspects of atmospherically relevant particle properties, ranging from water soluble salts via metallic particles and flame products to purely organic samples. Even well-defined mixtures of particles generated from the mixing of controlled flows of two independent particle generators were investigated. The chemical composition and hence the purity/degree of contamination of the particles was verified by a high resolution API-TOF mass spectrometer. The results show that the obtained counting efficiencies depend largely on the seed properties in this size range and on the charge state. In principle, I think this work fits well within the scopes of Atmos. Meas. Technol. and should be considered for publication. Still, to improve clarity several modifications and corrections as listed below are needed before this manuscript can finally be accepted.

General comments:

I think the term nano-CPC battery is somewhat misleading as its operation is quite different from the "regular" CPC battery. In this sense I would recommend explaining

in more detail how the nano-CPC battery differs from the CPC battery. Otherwise it sounds more like a CPC intercomparison than the characterization of a new set-up. For instance, based on this study the nano-CPC battery requires a DMA because there hasn't been any characterization of neutral particles. Also, I have not quite figured out what is the benefit of using the PSM in this set-up when all other instruments are laminar flow based and the DEG-CPC is part of the battery anyhow. Some more detailed explanations would be desirable. The nano-CPC battery was intended to be used (and was subsequently deployed) as a detector in an SMPS system. This laboratory study was designed to just characterize the detector. The following text has been added to reflect this distinction: "Combining the work of Kulmala et al. (2007) and Kuang et al. (2012a), our aim in this study is to construct and verify the performance of a nano-CPCb that will be used as a detector in an SMPS system. As a whole, this SMPS system consists of an aerosol neutralizer, a nano DMA, and the nano-CPCb which itself consists of four ultrafine CPCs optimized for the detection of sub 3 nm aerosols. For the PSM, our initial idea was to have it as a reference instrument in the setup until we found that butanol was actually much better liquid for activating organics than DEG. However the benefit of using the PSM is the high aerosol flow to the detector CPC which allows much higher counting statistics, as the signals obtained from the ambient are rather low for the smallest clusters.

Page 8857, line 14: reference to the description of the TDCIMS is better done with the following reference: Voisin, D., et al., *Aerosol Sci. Technol.* 37, 471 (2003). Changed the reference.

Page 8859, line 22: : aerosols AND THEIR GENERATION METHODS are listed in Table 2. Added

Page 8860, line 24: please explain to the reader why charger generated negative ions are not an issue here. I assume it is the different mobility size compared to the (larger) positive ions but it should be made clear. The authors view about this is the following: in the sub 1.5 nm sizes the charge carriers are defined by the proton affinities of the

C3947

clusters if there is an excess number of clusters. The charger generated ions are impurities that obtain charge from the primary ions since for some chemical reasons they are more stable as ions than for example N_2^+ or O_2^- . In addition there is of course much unknown chemistry and recombination etc going on which is not at all well known. When a large enough pool of clusters, that are more acidic or have lower proton affinity than the charged impurities, is added with the charger ions, the charge transfers to the sample clusters and which are able to hold it, thus making the charger generated ions "disappear" and the end product in the negative mode is only charged sample clusters. For positive ions, this is not the case since the clusters and molecules that have the highest proton affinity, in this case the charged contaminants, will keep their charge, as the sample clusters have lower proton affinity. Added couple of clarifying sentences to the text. "For these three samples, in negative mode when the sample concentration is high enough, there are no charger-generated ions present due to complete charge transfer to the sample clusters, which allows unambiguous sampling of the smallest negative clusters down to 1 nm, the composition of which is confirmed by the APi-TOF. The charge transfer is not complete in the positive mode, probably due to charger generated ions' higher proton affinity compared to the sample clusters."

Page 8861, lines 3,4: How did the authors generate those particles? It's shown in table 2, but it would also be good to have some details on the different particle generation techniques in the text. See also my comment above regarding page 8859, line 22. The details are given in page 8861 lines 12-29 and page 8862 lines 1-10

Page 8862, lines 13-18: please reformulate. Is it 10 Lpm through each generator (as suggested on line 13), or is it 10 Lpm total flow? Lines 17, 18 on this page state: "flow rate settings of the ammonium sulphate and tungsten oxide generators, respectively: 10 and 0 LPM, : : According to Figure 1 (lower panel) it should be 20 Lpm total flow. Added clarifying sentence. "The experiments were run at the following flow rate settings that were selected from the 10 lpm and 10 lpm flows of the ammonium sulphate and tungsten oxide generators, respectively: 10 and 0 lpm, 8 and

C3948

2 lpm, 6 and 4 lpm and so on. The resulting excess flows in order to maintain a final flow rate of 10 lpm through the cooler were sent through exhaust lines."

Page 8863, line 4: move sentence "The whole : : is presented in Fig. 1." somewhere to the beginning of this section. done

Page 8866, lines 6-8: please reformulate. Figs. 3 and 4 show different things. Only Fig. 4 shows ratios above unity. done

Page 8867, line 19: How were the d50 diameters determined? From a fit function? They were determined from a linear fit from the two closest points to value 0.5 which seemed to be enough for our needs.

Page 8868-8869, section 3.3 "Aerosol mixing state": the authors claim firmly that the resulting particles are internally mixed. How do they know? Is there a definition for internal/external mixture in the size range of 1-2 nm? To me it sounds more like externally mixed clusters as would be supported by the statement on page 8869, lines 17,18: "tungsten oxide clusters ATTACHED with persulphate". Unless there is good reason to believe those clusters are internally mixed I would be more cautious with such terminology. Our use of internal/external cluster mixtures refers only to whether or not the cluster population exists as a mixture of different single-component clusters (externally mixed) or as a mixture of multi-component clusters (internally mixed). We do not claim to know about the spatial distribution of species within a single cluster.

Page 8869, line 20: Figure 6 consists of an upper and a lower panel. There is no "a" and "b". Change text or label Figure 6 accordingly. done

Page 8870, line 1: same comment as previous. done

Page 8870, line 5: To me, Figure 6 (lower panel) is lacking a "clear bump". Those data are experimental data with some uncertainty. Please add symbols at corresponding flow rates indicating experimental error. Otherwise the lines are meaningless. Removed statement about "clear bump". Added relative 10% error bars which present the

C3949

uncertainty due to the CPC counting statistics, not perfectly stable aerosol concentration and electrometer noise.

Page 8870, line 7: similar comment as previous: sorry, I do not see a decreasing trend for the 3786 with increasing tungsten oxide flow rate. The trend is not seen from the figure, the data is. 10.0000 0.0060 8.0000 0.0055 6.0000 0.0092 4.0000 0.0109 2.0000 0.0120 0 0.0116 Added statement to text to line 364-366: "the total detection efficiency decreases from 0.012 to 0.006 as tungsten oxide flow rate increases from 0 to 10 lpm"

Page 8870, line 25: : : Fig. 6, lower panel,: : : corrected

Page 8871, lines 17-19: The conclusion that the results obtained justify the use of thenano-CPC battery in the field contradicts the experimental condition of close-to-zero relative humidity (page 8861, lines 20-23). The referee is correct and the authors agree that this effect should be somehow considered in the field studies. Attention will be paid for this in the potential field data analysis.

Page 8880, Table 3: activation efficiencies of THABr monomer and dimer are given in %. I am missing a factor 100 though. I guess it should be more like 0.1 to 3%, shouldn't it? Yes it should. Corrected.

Page 8882, Figure 1: This figure looks rather like a drawing in a lab book than a figure for presentation in a scientific paper. Remove the text in between the two panels as it appears in the figure caption anyhow. Please revise. Figure revised

Page 8883, figure caption: please add "(top)", "(middle)" and "(bottom)" at respective places. done

Page 8885: add "negative" and "positive" to figures as done in Fig. 3. done Edits:

Page 8860, line 11: : : flow of the counters was: : : added Line 14: : : nucleate: : : done Line 15: : : (Peinke et al., 2006): : : done

C3950

Page 8862, line 20: delete "again" done

Page 8865, line 23: : : interpretation: : : done

Page 8866, line 1: delete one "interpret" done

Page 8868, line 12: is it: " : : :we do now know: : : " or " : : :we do not know: : : "?
should be "not", corrected

Please also note the supplement to this comment:

<http://www.atmos-meas-tech-discuss.net/6/C3943/2014/amtd-6-C3943-2014-supplement.pdf>

Interactive comment on Atmos. Meas. Tech. Discuss., 6, 8855, 2013.

C3951

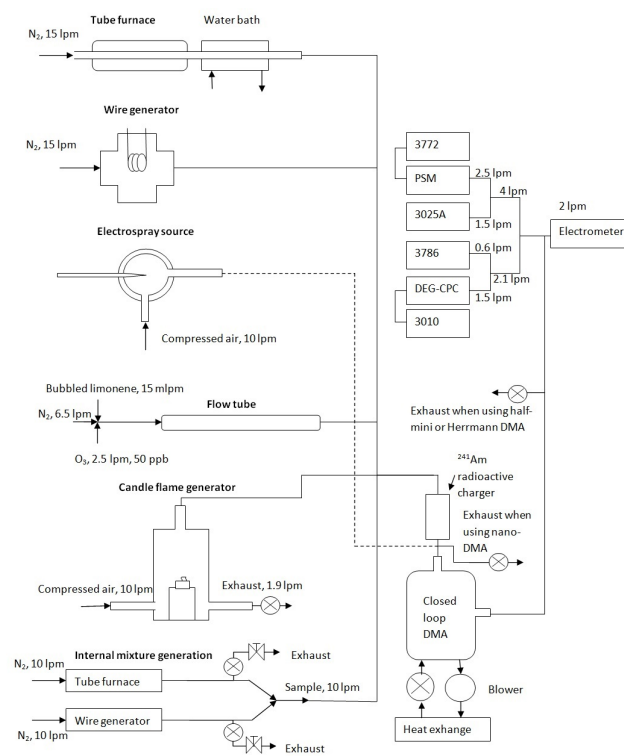

Fig. 1.

C3952

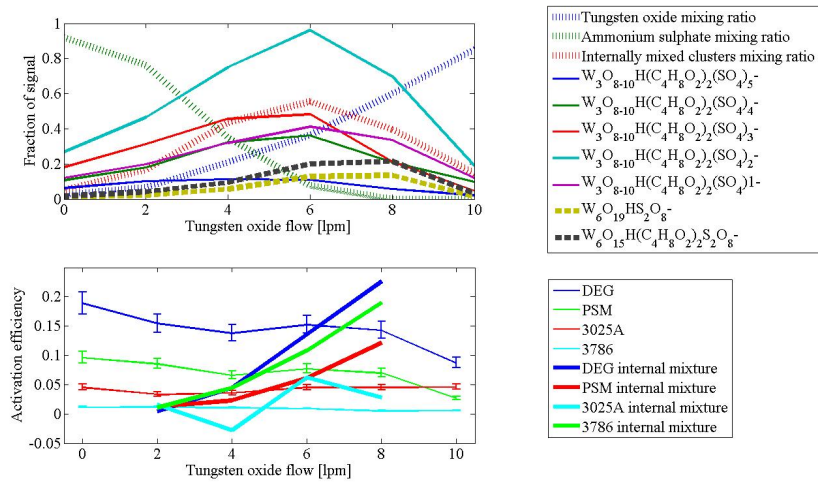

Fig. 2.

C3953

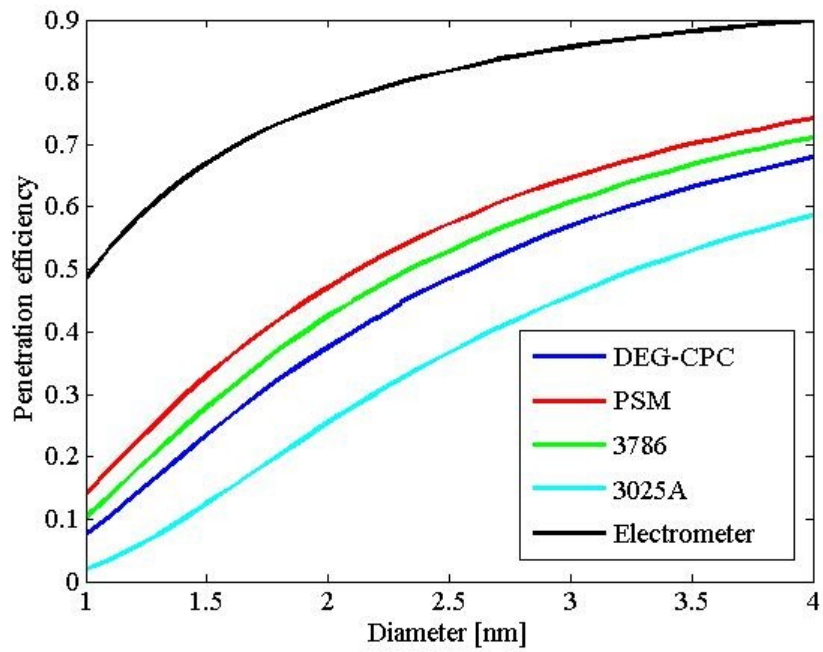

Fig. 3.

C3954