



This discussion paper is/has been under review for the journal Atmospheric Measurement Techniques (AMT). Please refer to the corresponding final paper in AMT if available.

# Quality-based generation of weather radar Cartesian products

K. Ośródka and J. Szturc

Institute of Meteorology and Water Management – National Research Institute,  
01-673 Warszawa, ul. Podleśna 61, Poland

Received: 21 October 2014 – Accepted: 23 October 2014 – Published: 25 November 2014

Correspondence to: J. Szturc (jan.szturc@imgw.pl)

Published by Copernicus Publications on behalf of the European Geosciences Union.

## Quality-based generation of weather radar Cartesian products

K. Ośródka and J. Szturc

Title Page

Abstract

Introduction

Conclusions

References

Tables

Figures



Back

Close

Full Screen / Esc

Printer-friendly Version

Interactive Discussion





with continuous progress in the field of correction algorithms, has continued with a view to operational work (Germann and Joss, 2004; Ośródk et al., 2010; Elo, 2012; Szturc et al., 2012a).

Raw weather radar data are generated as so called volumes, i.e. 3-D polar data.

Practically, such volumes consist of sets of measurement gates organised in polar scans related to the rotation of an antenna at selected elevation angles. The volumes are processed to obtain various 2-D Cartesian products dedicated to specific user requirements and based on the transfer from polar to Cartesian representations through a certain interpolation method (Heistermann et al., 2013).

In order to ensure maximum reliability of the final products, the transformation and subsequent specific product generation should be quality-based, i.e. particular algorithms should be designed, taking into account the quality of particular measurement gates. Therefore the quality index fields assigned to reflectivity volumes should play an essential role in the task of 2-D product generation.

The paper is organised in the following way: since in the research information about the weather radar data quality is incorporated into radar product definitions, an example of the method of quality characterisation is briefly described in Sect. 2. The technique is based on algorithms developed for the RADVOL-QC package. Based on 3-D volumes of reflectivity and relevant quality information, the set of 2-D Cartesian PPI (plan position indicator) products may be generated (Sect. 3) as a starting point for the generation of more sophisticated products such as: echo top (ETOP), maximum of reflectivity (MAX) and vertically integrated liquid water (VIL) (Sect. 4). As well as this, a non-standard product named CONVECTION, which is dedicated to the identification of convective area based on all the previously described products, is defined. Finally, in Sect. 5, the technique of QI field determination for the above products is described.

## Quality-based generation of weather radar Cartesian products

K. Ośródk and J. Szturc

Title Page

Abstract

Introduction

Conclusions

References

Tables

Figures



Back

Close

Full Screen / Esc

Printer-friendly Version

Interactive Discussion



## 2 The characterisation of 3-D weather radar data quality

### 2.1 Data

The framework of quality-based products was tested on data from the Polish weather radar network POLRAD, which consists of eight C-Band radars with the scan strategy described in Table 1. The strategy included 10 scans at elevations from 0.5 to 23.8° with a beam width of 1°. Sampling was performed every kilometre along the beam for 360 azimuths.

### 2.2 Quality index approach

The quantitative estimation of error magnitude is necessary not only in order to gain general knowledge about data uncertainty, but also to apply quality information in further data processing, e.g. in the generation of standard or user-related specific products. One of the most common approaches in the characterisation of the quality of weather radar data is to employ quality index (QI) that is defined as a unitless quantity which provides information on the data reliability in a digital scale. Most often, the QI ranges from 0 (for the poorest quality) to 1 (for the best data), according to EUMETNET OPERA definition (Michelson et al., 2014), but other definitions can also be found (see review provided by Einfalt et al., 2010).

Each category of errors burdening radar data is characterised by specific properties, spatial and temporal structure, and the possibility of diagnosis and correction; this consequently requires dedicated quality control techniques. Thus, the processing of the radar data is performed in a certain number of steps and after each one the data quality improves and a particular QI field is generated. Having determined a set of quality indices, a total QI field describing overall data quality can be computed, for example by using a multiplicative scheme (Ośródka et al., 2014).

## Quality-based generation of weather radar Cartesian products

K. Ośródka and J. Szturc

Title Page

Abstract

Introduction

Conclusions

References

Tables

Figures



Back

Close

Full Screen / Esc

Printer-friendly Version

Interactive Discussion



## 2.3 RADVOL-QC algorithms

In this research the quality control of radar reflectivity volumes was performed by means of dedicated software – RADVOL-QC – which was developed to correct the data and generate QI fields (Ośródka et al., 2014). The software was integrated with the BALTRAD system for radar data exchange (Michelson et al., 2012), where it can work on data in HDF5 file format according to the EUMETNET OPERA digital information model ODIM (Michelson et al., 2014). Additionally, in the Institute of Meteorology and Water Management – National Research Institute (IMGW-PIB) the RADVOL-QC version developed for Gematronik Rainbow radar software works as a volume post-processing of data in native Rainbow format.

The RADVOL-QC is still under development and at present it consists of the following algorithms for data control (Ośródka et al., 2014; Szturc et al., 2012b):

- quality characterisation due to effects related to the distance to a radar site (BROAD),
- removal of conventional non-meteorological echoes (NMET),
- removal of geometrically-shaped non-meteorological echoes caused by external signal interference (SPIKE),
- removal of measurement noise (SPECK),
- correction due to partial and total beam blockage (BLOCK),
- correction due to attenuation in rain (ATT).

The algorithms enable both the correction of data (excepting BROAD) and the estimation of the data quality expressed as QI.

## Quality-based generation of weather radar Cartesian products

K. Ośródka and J. Szturc

Title Page

Abstract

Introduction

Conclusions

References

Tables

Figures

◀

▶

◀

▶

Back

Close

Full Screen / Esc

Printer-friendly Version

Interactive Discussion



### 3 Quality-based transformation of 3-D polar data into 2-D Cartesian data: set of PPI products

The raw data volume is organised in a set of scans consisting of measurement gates expressed in polar coordinates: scan elevation angle ( $\varepsilon$ ), azimuth ( $\alpha$ ), and the distance from the radar site to the gate along the radar beam ( $l$ ). For further processing every scan needs to be transformed into Cartesian coordinates ( $x$ ,  $y$ ). This is achieved by looping through all the Cartesian pixels of the 2-D output field and finding the corresponding neighbouring polar gates by means of trigonometric functions (Elo, 2012; Selex, 2010).

Here, an algorithm based on spatial interpolation of polar reflectivity data with respect to quality index QI data is applied to find the Cartesian reflectivity  $Z$  data as PPI (plan position indicator) product and generate a corresponding QI field. Following this, standard products, such as MAX, VIL, etc., can be generated based on the set of PPIs and related quality information.

#### 3.1 PPI product quality-based generation

PPI is one of the standard Cartesian products that represents reflectivity data generated from a single radar scan for constant elevation angle  $\varepsilon$ . The algorithm transforms values for measurement gates of polar coordinates ( $\varepsilon$ ,  $\alpha$ ,  $l$ ) into values interpolated for Cartesian pixels defined by coordinates ( $x$ ,  $y$ ). Usually, the transformation is performed while considering two or four of the closest gates, and not considering the quality of particular gates.

In the proposed technique, the method of the quality-based interpolation depends on the density of the gates within the given Cartesian pixel. If the number of the gates is larger than the preset threshold then they all are taken into interpolation (the so called “inside” sub-algorithm); otherwise, a maximum of four gates (independently of their distances to the Cartesian pixel centre) are considered (the “outside” sub-algorithm).

## Quality-based generation of weather radar Cartesian products

K. Ośróodka and J. Szturc

Title Page

Abstract

Introduction

Conclusions

References

Tables

Figures



Back

Close

Full Screen / Esc

Printer-friendly Version

Interactive Discussion



In order to distinguish between the “inside” and “outside” pixels a threshold value for distance from the radar site ( $D$ ) is determined by the following empirical function of the measurement parameters:

$$D = \sqrt{\frac{9500 \left( \frac{1.3}{d\alpha} + \frac{2.3}{dI} + 1.6dx \right) - 39\,000}{\pi}} \quad (1)$$

5 where  $d\alpha$  is the step in azimuth ( $^\circ$ ),  $dI$  is the step in distance from the radar site (km), and  $dx$  is the spatial resolution of Cartesian pixel (km). For instance, for typical data resolution  $d\alpha = 1^\circ$ ,  $dI = 1$  km, and  $dx = 1$  km, the threshold  $D$  equals 57.5 km.

10 *The “inside” sub-algorithm.* In cases when the distance from the radar site to the given Cartesian pixel does not exceed the threshold distance  $D$ , then the number of gates within the pixel is determined. If this number is higher than two, the inside method based on quality weighted interpolation is used:

$$Z(x, y) = \frac{\sum_{i=1}^n (Z_i QI_i)}{\sum_{i=1}^n QI_i} \quad (2)$$

where  $n$  is the number of gates within the investigated area.

15 Otherwise, if the number of gates is not higher than two, the “outside” sub-algorithm is applied.

20 *The “outside” sub-algorithm.* In the outside area the closest gates are determined in a different way. The coordinates of the Cartesian pixel centre are transformed into polar coordinates and the four surrounding gates are taken into account. Generally, the reflectivity for the pixel is interpolated from the four corner values (Fig. 1), unless some of the corners (one or two) are very close to the considered pixel centre – then only the closest gates are taken into calculation.

Reflectivity in a given pixel with centre in  $(x, y)$  is estimated as weighing an average value  $Z(x, y)$  from selected gates  $Z_i$ , taking account of both distance to the gates and data quality information (quality index  $QI_i$ ):

$$Z(x, y) = \frac{\sum_{i=1}^n (Z_i W_{D_i} QI_i)}{\sum_{i=1}^n (W_{D_i} QI_i)} \quad (3)$$

- 5 where:  $n$  is the number of the closest gates taken into account (1, 2, or 4);  $W_{D_i}$  is the weight related to the distance of  $i$ -gate to the pixel centre  $(x, y)$  determined by means of one of the standard methods: nearest neighbour, uniform weights, inverse distance to the first or second power, bilinear method, and Cressman method.

### 3.2 Data quality characterisation

- 10 Simultaneously to the determination of reflectivity for each Cartesian pixel  $(x, y)$ , the relevant quality index is calculated, depending on the sub-algorithm applied to the data interpolation:

- for the inside sub-algorithm:

$$QI(x, y) = \frac{\sum_{i=1}^n QI_i}{n}, \quad (4)$$

- 15 – for the outside sub-algorithm:

$$QI(x, y) = \frac{\sum_{i=1}^n (QI_i W_{D_i})}{\sum_{i=1}^n W_{D_i}} \quad (5)$$



### 3.3 Example

Differences in the overall view of 2-D products generated employing the abovementioned methods are not very noticeable. However, they can be significant for the estimation of precipitation for small river catchments in cases of flash floods. Therefore, in Fig. 2 excerpts of radar PPIs obtained by means of different interpolation methods are demonstrated.

As was expected, the radar beam structure is most evident in the nearest neighbour method. The other methods are more smoothed and it seems that the bilinear method (Fig. 2d) gives a field with local extremes and an isohyet pattern reflected in the best way.

## 4 Examples of quality-based 2-D radar reflectivity products based on PPI set

A set of PPIs fields of reflectivity (with related QI) generated from radar data volume may constitute a basis for defining many standard 2-D products, as described below – ETOP, MAX, and VIL. Moreover, a CONVECTION product developed for the identification of a convection area is presented here. Quality information plays a crucial role in the definition of the products.

### 4.1 Quality-based echo top product (ETOP)

The echo top (ETOP) product represents a Cartesian image of heights of echo (cloud) tops defining the cloud boundary at a preset level of radar reflectivity  $Z_0$  (in dBZ). The ETOP (in km) is detected in a preset range of heights (between  $h_{\min}$  and  $h_{\max}$ ) and generally is determined by interpolation of reflectivity  $Z$  in pixel  $(x, y)$  between the two highest PPIs for which the reflectivity passes  $Z_0$  value.

If the searched height of  $Z_0$  value is between two measurements  $Z'$  and  $Z''$ , detected at heights  $h'$  and  $h''$  respectively, then in order to find the height ETOP at which echo

**Quality-based  
generation of  
weather radar  
Cartesian products**

K. Ośróodka and J. Szturc

Title Page

Abstract

Introduction

Conclusions

References

Tables

Figures

⏪

⏩

◀

▶

Back

Close

Full Screen / Esc

Printer-friendly Version

Interactive Discussion



top occurs ( $Z = Z_0$ ) the linear interpolation is applied:

$$ETOP = \frac{(Z_0 - Z'')(h' - h'')}{(Z' - Z'')} + h'' \quad (6)$$

In cases where both considered measurements are with echo ( $Z \geq Z_0$ ) then:

$$ETOP = \min(h_{\max}, \max(h', h'')). \quad (7)$$

- 5 If there is no measurement between  $h_{\min}$  and  $h_{\max}$  then the product value is “nodata”. The algorithm is depicted in Fig. 3a.

## 4.2 Quality-based maximum of reflectivity product (MAX)

10 The maximum of reflectivity (MAX) product represents a Cartesian image of the highest measured value of radar reflectivity  $Z$  (in dBZ) in each vertical column. Generally, the product generation involves searching PPIs within a preset range of heights (between  $h_{\min}$  and  $h_{\max}$ ) for the maximal  $Z$  value in the column (Fig. 3b).

## 4.3 Quality-based vertically integrated liquid water (VIL) product

15 The vertically integrated liquid water (VIL) product represents a Cartesian image of the water content residing in a user-defined layer in the atmosphere (in dBA). The VIL is defined by the formula:

$$VIL \text{ (dBA)} = 10 \log_{10} \int_{h_{\min}}^{h_{\max}} M(h) dh \quad (8)$$

where the liquid water content  $M$  (in  $\text{cm}^3 \text{m}^{-3}$ ) is related to radar reflectivity  $Z$  according to so called  $Z-M$  relationship in the form:

$$Z(\text{mm}^6 \text{m}^{-3}) = cM^d \text{ or } M(\text{cm}^3 \text{m}^{-3}) = \left(\frac{Z}{c}\right)^{\frac{1}{d}} \quad (9)$$

11720

Title Page

Abstract

Introduction

Conclusions

References

Tables

Figures

◀

▶

◀

▶

Back

Close

Full Screen / Esc

Printer-friendly Version

Interactive Discussion



where:  $c = 24\,000$ ;  $d = 1.82$  (as proposed by Selex, 2010).

In order to find the vertical profile of liquid water content,  $M(h)$ , the values between each two neighbouring measurements  $M'$  and  $M''$  detected at heights  $h'$  and  $h''$  respectively are interpolated linearly:

$$M(h) = \frac{(h - h'')(M' - M'')}{(h' - h'')} + M'' \quad (10)$$

Then the VIL in a preset range of heights (between  $h_{\min}$  and  $h_{\max}$ ) is calculated by the integration of the profile in this range.

The integration range depends on values of both the required heights (between  $h_{\min}$  and  $h_{\max}$ ) and the measurement availability (between  $h_{\text{lowest}}$  and  $h_{\text{highest}}$ ) – the integration is performed from the lower height of the bottom limits to the lower height of the upper limits. The algorithm is depicted in Fig. 5c and d.

#### 4.4 Quality-based detection of convection (CONVECTION) product

The algorithm for the separation of convective precipitation from stratiform background was developed as the first stage of the SCENE (Storm Cell Evolution and Nowcasting) model of precipitation nowcasting which forecasts convective and stratiform precipitation in different ways (Jurczyk et al., 2014). Radar reflectivity data provides one of the most significant pieces of information in the algorithm and in an elementary version only radar information is employed (without data from other sources).

The dedicated radar product named CONVECTION is a second-order product as it is generated not from a set of PPIs but from earlier produced ETOP, MAX, and VIL products. Moreover, the horizontal structure of the radar reflectivity field turned out to also be a useful factor for distinguishing between convective and stratiform precipitation, therefore the fields of parameters computed from the analysis of the spatial structure of the MAX and VIL (Jurczyk et al., 2012) are factors in CONVECTION field determination: exceedance of the Z background ( $\Delta Z = Z/Z_{\text{mean}}$ ) and exceedance of the VIL background ( $\Delta \text{VIL} = \text{VIL}/\text{VIL}_{\text{mean}}$ ). The two parameters are calculated as a ratio of

### Quality-based generation of weather radar Cartesian products

K. Ośróodka and J. Szturc

Title Page

Abstract

Introduction

Conclusions

References

Tables

Figures



Back

Close

Full Screen / Esc

Printer-friendly Version

Interactive Discussion



the value in a considered pixel to the average of the rain pixels within the surrounding background of an 11 km radius (respectively  $Z_{\text{mean}}$  and  $VIL_{\text{mean}}$  values).

The algorithm was designed employing a fuzzy logic approach. For both precipitation classes (convective C or stratiform S) membership functions are defined for the five parameters described above. Then the functions' values are aggregated as weighted sums for the classes:

$$\mu_{\text{class}} = \sum_x \mu_{\text{class}}(x) \cdot W_{\text{class}}(x) \quad (11)$$

where class is the precipitation class (C or S);  $x$  is the convection parameter;  $\mu_{\text{class}}(x)$  is the membership function value for  $x$ -parameter;  $W_{\text{class}}(x)$  is the weight of  $x$ -parameter. Comparison of the weighted sums for the classes decides which category C or S a considered precipitation pixel belongs to.

## 5 Characterisation of product quality

Generally, the quality of the 2-D products expressed by quality index QI depends on two factors:

- the quality of reflectivity data from which a given product was determined,  $QI_{\text{source}}$ ,
- how large a fraction of investigated heights (between  $h_{\text{min}}$  and  $h_{\text{max}}$ ) was scanned,  $QI_{\text{scope}}$ ,

and the final quality index QI is taken as their product:

$$QI = QI_{\text{source}} \cdot QI_{\text{scope}} \quad (12)$$

The value of the first component  $QI_{\text{source}}$  is taken as the quality of the PPI products defining the given product, namely:

### Quality-based generation of weather radar Cartesian products

K. Ośróodka and J. Szturc

Title Page

Abstract

Introduction

Conclusions

References

Tables

Figures

⏪

⏩

◀

▶

Back

Close

Full Screen / Esc

Printer-friendly Version

Interactive Discussion



## Quality-based generation of weather radar Cartesian products

K. Ośróodka and J. Szturc

Title Page

Abstract

Introduction

Conclusions

References

Tables

Figures

◀

▶

◀

▶

Back

Close

Full Screen / Esc

Printer-friendly Version

Interactive Discussion



- for ETOP, the  $QI_{source}$  is obtained from the QI value in the pixel for which the ETOP was observed; and in cases of interpolation from two measurements, the minimum quality is chosen,
- for MAX the QI of the pixel for which MAX was observed is taken as the  $QI_{source}$ ,
- for VIL, which depends on all PPI values within an integration range, the  $QI_{source}$  is taken as an average quality of all PPIs defining the specific VIL.

For all the products, if the value of a given product equals “nodata”, then the  $QI_{source} = \text{“nodata”}$  (and also the final QI = “nodata”), and if it equals “undetected” then the  $QI_{source} = 1$ .

The second component,  $QI_{scope}$ , is determined based on the heights of the highest and lowest scans for a considered Cartesian pixel ( $h_{highest}$  and  $h_{lowest}$  respectively) in relation to  $h_{min}$  and  $h_{max}$ . Its value depends on what part of the height range between  $h_{min}$  and  $h_{max}$  defining the given product was scanned (Fig. 4 and Table 2).

The above procedure of quality determination is applied to first-order products like ETOP, MAX, and VIL. The quality index for a CONVECTION product is defined by the values of the two considered membership functions (see Eq. 11):

$$QI = \sqrt{\frac{|\mu_C - \mu_S|}{\mu_C + \mu_S}} \quad (13)$$

## 6 Example

A quality field usually has a very diversified spatial pattern and is dynamic in time. It is demonstrated in Fig. 5 for example data observed on the Ramža radar, where a quality index for the lowest PPI depicted in polar coordinates is presented together with the lowest raw and corrected reflectivity PPIs. In this case, apart from numerous non-meteorological echoes detected near the radar site, extremely strong attenuation caused by hail (of reflectivity of up to 65 dBZ) is observed.

---

**Quality-based generation of weather radar Cartesian products**

---

K. Ośróodka and J. Szturc

---

[Title Page](#)[Abstract](#)[Introduction](#)[Conclusions](#)[References](#)[Tables](#)[Figures](#)[⏪](#)[⏩](#)[◀](#)[▶](#)[Back](#)[Close](#)[Full Screen / Esc](#)[Printer-friendly Version](#)[Interactive Discussion](#)

The radar data volume is the basis for the generation of the 2-D products described above. In Fig. 6, the products generated from the example volume are demonstrated: the lowest PPI, ETOP, MAX, VIL, and CONVECTION, along with the related quality fields.

5 The first four products are similar to ones obtained using standard algorithms. The relevant quality index fields are mostly influenced by the following factors: distance to the radar site, beam attenuation due to heavy hail in the south-west sector, and the fraction of scanned heights resulting from the scan strategy. The CONVECTION field indicates pixels where convection is detected according to the algorithm described in  
10 Sect. 4. The quality of this product depends on values of membership functions of both classes and may be connected with the probability of the presence of convection in a given pixel.

## 7 Conclusions

15 Reliable quality information is crucial for user-expected radar-based products because it can be helpful in the generation of more advanced information for various applications. The quality index (QI) was found to be an appropriate quality metric. A starting point for this research was processing by means of RADVOL-QC software, which corrects weather radar data and provides the total QI as a result of considering selected quality factors.

20 The proposal to generate some 2-D products from 3-D raw radar data in a more advanced way, when compared with standard procedures (e.g. Selex, 2010) is presented here. The main idea of the proposal is that interpolation of 3-D data into a set of PPIs and then into other 2-D products is performed in an optimal way, employing quality information related to each measurement point (gate). Here the following quality-based  
25 versions of standard products are defined: MAX, Echo Top, and VIL. Moreover, the CONVECTION product for the identification of convective precipitation based on the abovementioned products is described as an example of more advanced quality-based

## Quality-based generation of weather radar Cartesian products

K. Ośródkka and J. Szturc

Title Page

Abstract

Introduction

Conclusions

References

Tables

Figures

◀

▶

◀

▶

Back

Close

Full Screen / Esc

Printer-friendly Version

Interactive Discussion



radar products. It is expected that the final products will be of higher reliability not only thanks to previous correction steps, but also because of the skilled introduction of quality information into the algorithms of product generation.

The quality information assigned to the generated product also seems very important. It is obvious that individual schemes of quality characterisation for each specific product should be developed. However, a consistent framework needs to be agreed and implemented. The paper presents a proposal of such a framework.

The essential role of quality information in radar data processing is commonly appreciated. Areas where it may play an important role include the estimation of radar-based and multi-source (combined) surface rainfall rate, the generation of more reliable hazard indices for various services like civil protection or air traffic control, and especially the generation of probabilistic rainfall fields in the form of data ensemble or percentiles, as well as various other areas.

*Acknowledgements.* The paper was prepared within the framework of the BALTRAD and BALTRAD+ Projects (under the Baltic Sea Region Programme 2007–2013 fund). The authors are especially grateful to Daniel Michelson (SMHI) and Jarmo Koistinen (FMI) for their cooperation and inspiring discussions during work on the projects.

## References

- Einfalt, T. and Michaelides, S.: Quality control of precipitation data, in: *Precipitation: Advances in Measurement, Estimation and Prediction*, edited by: Michaelides, S., Springer Verlag, Berlin Heidelberg, 101–126, 2008.
- Einfalt, T., Szturc, J., and Ośródkka, K.: The quality index for radar precipitation data: a tower of Babel?, *Atmos. Sci. Let.*, 11, 139–144, 2010.
- Elo, C. A.: Correcting and quantifying radar data, *Met.no report*, 2/2012, 34 pp., 2012.
- Germann, U. and Joss, J.: Operational measurement of precipitation in mountainous terrain, in: *Weather Radar: Principles and Advanced Applications*, edited by: Meischner, P., Springer Verlag, Berlin Heidelberg, 52–77, 2004.

## Quality-based generation of weather radar Cartesian products

K. Ośródką and J. Szturc

[Title Page](#)
[Abstract](#)
[Introduction](#)
[Conclusions](#)
[References](#)
[Tables](#)
[Figures](#)
[Back](#)
[Close](#)
[Full Screen / Esc](#)
[Printer-friendly Version](#)
[Interactive Discussion](#)

Heistermann, M., Jacobi, S., and Pfaff, T.: Technical Note: An open source library for processing weather radar data (*wradlib*), *Hydrol. Earth Syst. Sci.*, 17, 863–871, doi:10.5194/hess-17-863-2013, 2013.

Jurczyk, A., Ośródką, K., and Szturc, J.: Convective cell identification using multi-source data, *IAHS Publ.*, 351, 360–365, 2012.

Jurczyk, A., Szturc, J., and Ośródką, K.: SCENE: nowcasting for convective and stratiform precipitation, *Meteorol. Appl.*, submitted, 2014.

Michelson, D., Einfalt, T., Holleman, I., Gjertsen, U., Friedrich, K., Haase, G., Lindskog, M., and Jurczyk, A.: Weather Radar Data Quality in Europe: Quality Control and Characterisation. Review. COST Action 717 – Use of Radar Observations in Hydrological and NWP Models, Luxembourg, 87 pp., 2005.

Michelson, D., Koistinen, J., Peltonen, T., Szturc, J., and Rasmussen, M. R.: Advanced weather radar networking with BALTRAD+, in: *Proc. 7th European Conference on Radar in Meteorology and Hydrology ERAD 2012*, Toulouse, France (CD), 2012.

Michelson, D. B., Lewandowski, R., Szewczykowski, M., Beekhuis, H., and Haase, G.: EU-METNET OPERA Weather Radar Information Model for Implementation with the HDF5 File Format, Version 2.2, EUMETNET OPERA Document, 2014.

Ośródką, K., Jurczyk, A., Dziewit, Z., Szturc, J., and Korpus, L.: MeteoFlight: System of Weather Hazard Monitoring for Air Traffic Control, in: *Proc. 6th European Conference on Radar in Meteorology and Hydrology ERAD 2010*, Sibiu, Romania (CD), 2010.

Ośródką, K., Szturc, J., and Jurczyk, A.: Chain of data quality algorithms for 3-D single-polarization radar reflectivity (RADVOL-QC system), *Meteorol. Appl.*, 21, 256–270, 2014.

Selex: Rainbow 5. Products and algorithms, Release 5.31.0, Selex SI GmbH, Neuss, 442 pp., 2010.

Szturc, J., Michelson, D., Koistinen, J., Haase, G., Plura, M., Gill, R., Sørensen, M., Ośródką, K., and Jurczyk, A.: Data quality in the BALTRAD+ project, in: *Proc. 7th European Conference on Radar in Meteorology and Hydrology ERAD 2012*, Toulouse, France (CD), 2012a.

Szturc, J., Ośródką, K., and Jurczyk, A.: Quality control algorithms applied on weather radar reflectivity data, in: *Doppler Radar Observations – Weather Radar, Wind Profiler, Ionospheric Radar, and other Advanced Applications*, edited by: Bech, J. and Chau, J. L., InTech, 289–306, 2012b.



## Quality-based generation of weather radar Cartesian products

K. Ośróodka and J. Szturc

**Table 1.** Scan parameters currently used in the POLRAD weather radar network of IMGW.

Parameter	Value
Radar beam width	1°
Number of azimuths	360
Maximum range from radar site	250 km
Distance between sampling along radar beam	1 km
Number of elevations	10
Elevation angles (°)	0.5, 1.4, 2.4, 3.4, 5.3, 7.7, 10.6, 14.1, 18.5, 23.8

Title Page

Abstract

Introduction

Conclusions

References

Tables

Figures



Back

Close

Full Screen / Esc

Printer-friendly Version

Interactive Discussion



## Quality-based generation of weather radar Cartesian products

K. Ośródką and J. Szturc

**Table 2.** Scheme of algorithm for  $QI_{\text{scope}}$  determination.

Case	$QI_{\text{scope}}$ determination
$h_{\text{highest}} \leq h_{\text{min}}$	$QI_{\text{scope}} = \text{"nodata"}$ (and $QI = \text{"nodata"}$ )
$h_{\text{min}} \leq h_{\text{highest}} \leq h_{\text{max}}$ and $h_{\text{lowest}} \leq h_{\text{min}}$	$QI_{\text{scope}} = \frac{h_{\text{highest}} - h_{\text{min}}}{h_{\text{max}} - h_{\text{min}}}$
$h_{\text{highest}} \geq h_{\text{max}}$ and $h_{\text{lowest}} \leq h_{\text{min}}$	$QI_{\text{scope}} = 1$
$h_{\text{highest}} \geq h_{\text{max}}$ and $h_{\text{min}} \leq h_{\text{lowest}} \leq h_{\text{max}}$	$QI_{\text{scope}} = \frac{h_{\text{max}} - h_{\text{lowest}}}{h_{\text{max}} - h_{\text{min}}}$ but for ETOP if ETOP $\neq$ undetect then $QI_{\text{scope}} = 1$
$h_{\text{lowest}} \geq h_{\text{max}}$	$QI_{\text{scope}} = \text{"nodata"}$ (and $QI = \text{"nodata"}$ )

Title Page

Abstract

Introduction

Conclusions

References

Tables

Figures

◀

▶

◀

▶

Back

Close

Full Screen / Esc

Printer-friendly Version

Interactive Discussion



## Quality-based generation of weather radar Cartesian products

K. Ośródką and J. Szturc

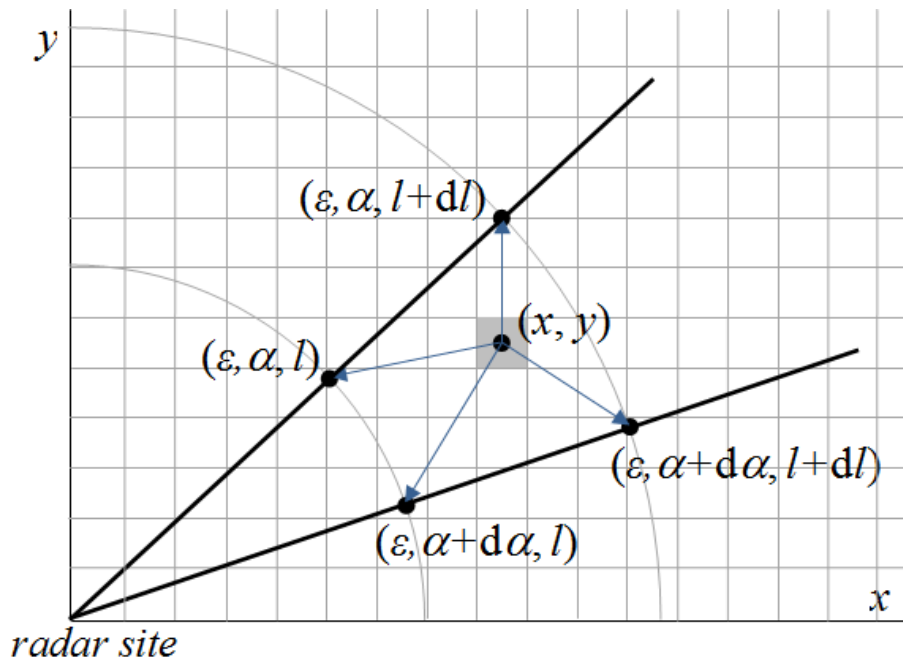

**Figure 1.** Scheme of interpolation of gate values into Cartesian pixel.

Title Page

Abstract

Introduction

Conclusions

References

Tables

Figures

◀

▶

◀

▶

Back

Close

Full Screen / Esc

Printer-friendly Version

Interactive Discussion



## Quality-based generation of weather radar Cartesian products

K. Ośródką and J. Szturc

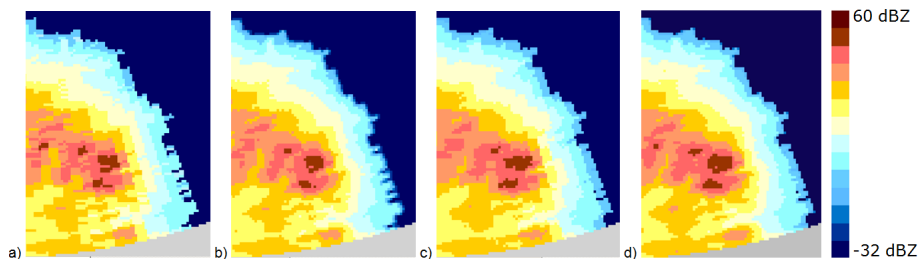

**Figure 2.** Examples of interpolation of polar into Cartesian data using methods: nearest neighbour, inverse distance to the second power, Cressman, and bilinear (excerpt from Legionowo radar, 20 July 2011, 00:00 UTC).

Title Page

Abstract

Introduction

Conclusions

References

Tables

Figures

◀

▶

◀

▶

Back

Close

Full Screen / Esc

Printer-friendly Version

Interactive Discussion



## Quality-based generation of weather radar Cartesian products

K. Ośródką and J. Szturc

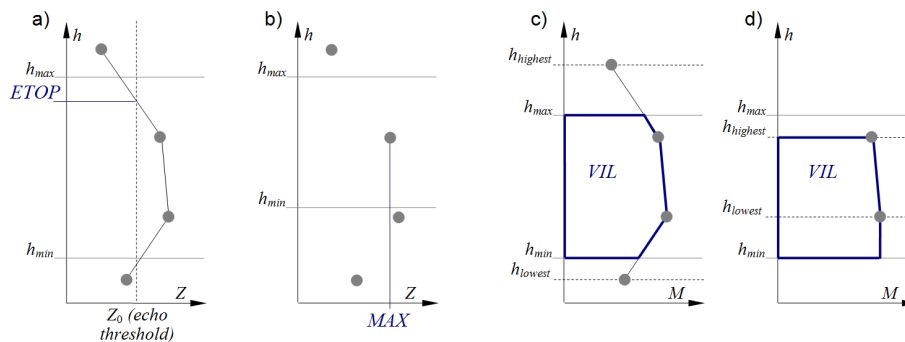
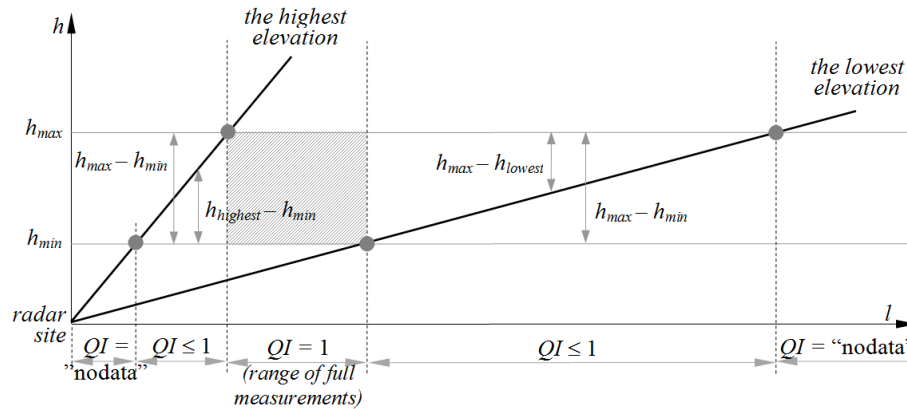

**Figure 3.** Schemes of generation of products from reflectivity  $Z$  values at particular PPIs: **(a)** Echo Top, ETOP; **(b)** maximum of reflectivity, MAX; **(a and d)** vertically integrated liquid water, VIL (two cases of measurement availability in the vertical profile are depicted).

[Title Page](#)
[Abstract](#)
[Introduction](#)
[Conclusions](#)
[References](#)
[Tables](#)
[Figures](#)
[◀](#)
[▶](#)
[◀](#)
[▶](#)
[Back](#)
[Close](#)
[Full Screen / Esc](#)
[Printer-friendly Version](#)
[Interactive Discussion](#)

## Quality-based generation of weather radar Cartesian products

K. Ośródko and J. Szturc



**Figure 4.** Quality  $QI_{\text{scope}}$  determination for 2-D product in terms of availability.

Title Page	
Abstract	Introduction
Conclusions	References
Tables	Figures
◀	▶
◀	▶
Back	Close
Full Screen / Esc	
Printer-friendly Version	
Interactive Discussion	



## Quality-based generation of weather radar Cartesian products

K. Ośródko and J. Szturc

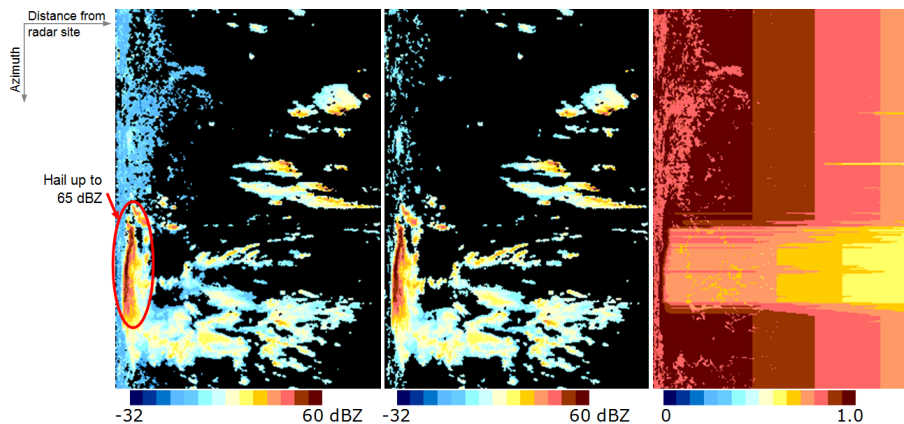

**Figure 5.** The lowest scan ( $0.5^\circ$ ) in volume from 10 June 2013, 14:00 UTC, Ramża radar, in polar coordinates. From the left: raw data, corrected data, and quality index.

[Title Page](#)[Abstract](#)[Introduction](#)[Conclusions](#)[References](#)[Tables](#)[Figures](#)[◀](#)[▶](#)[◀](#)[▶](#)[Back](#)[Close](#)[Full Screen / Esc](#)[Printer-friendly Version](#)[Interactive Discussion](#)

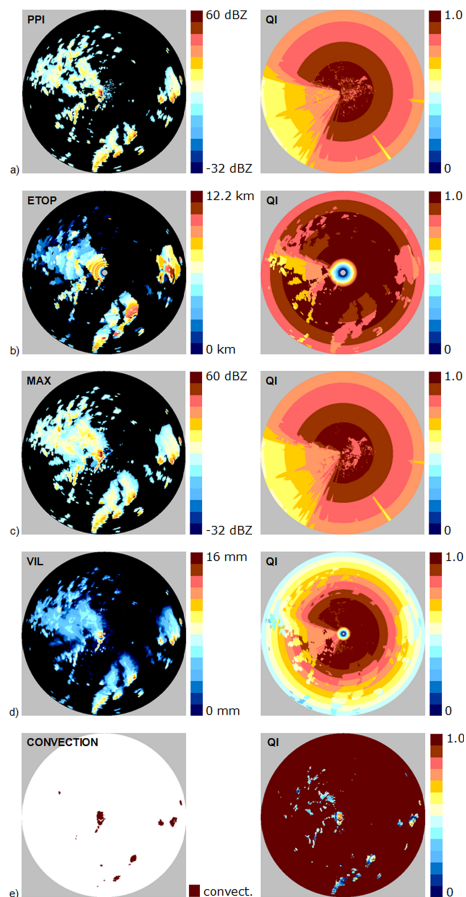

**Figure 6.** Cartesian radar products: (a) PPI at 0.5°, (b) ETOP with 4 dBZ as cloud boundary, (c) MAX, (d) VIL, (e) CONVECTION (Ramża radar, 10 June 2013, 14:00 UTC).

**Quality-based generation of weather radar Cartesian products**

K. Ośródką and J. Szturc

Title Page

Abstract

Introduction

Conclusions

References

Tables

Figures

◀

▶

◀

▶

Back

Close

Full Screen / Esc

Printer-friendly Version

Interactive Discussion

