



This discussion paper is/has been under review for the journal Atmospheric Measurement Techniques (AMT). Please refer to the corresponding final paper in AMT if available.

Pressure dependent HO_x calibrations

F. A. F. Winiberg et al.

Pressure dependent calibration of the OH and HO_x channels of a FAGE HO_x instrument using the Highly Instrumented Reactor for Atmospheric Chemistry (HIRAC)

F. A. F. Winiberg¹, S. C. Smith¹, I. Bejan¹, C. A. Brumby¹, T. Ingham^{1,2},
T. L. Malkin^{1,*}, S. C. Orr¹, D. E. Heard^{1,2}, and P. W. Seakins^{1,2}

¹School of Chemistry, University of Leeds, LS2 9JT, UK

²National Centre for Atmospheric Science, University of Leeds, LS2 9JT, UK

* now at: Institute for Climate and Atmospheric Science, School of Earth and Environment, University of Leeds, Woodhouse Lane, Leeds, LS2 9JT, UK

Received: 19 June 2014 – Accepted: 14 July 2014 – Published: 31 July 2014

Correspondence to: P. W. Seakins (p.w.seakins@leeds.ac.uk)

Published by Copernicus Publications on behalf of the European Geosciences Union.

Title Page

Abstract

Introduction

Conclusions

References

Tables

Figures



Back

Close

Full Screen / Esc

Printer-friendly Version

Interactive Discussion



Abstract

The calibration of field instruments used to measure concentrations of OH and HO₂ worldwide have traditionally relied on a single method utilising the photolysis of water vapour in air in a flow tube at atmospheric pressure. Here the calibration of two FAGE (Fluorescence Assay by Gaseous Expansion) apparatuses designed for HO_x (OH and HO₂) measurements have been investigated as a function of external pressure and temperature, using two different laser systems. The conventional method of generating known concentrations of HO_x from H₂O vapour photolysis in a turbulent flowtube impinging just outside the FAGE sample inlet has been used to study instrument sensitivity as a function of internal fluorescence cell pressure (1.8–3.8 mbar). An increase in the calibration constants C_{OH} and C_{HO_2} with pressure was observed and an empirical linear regression of the data was used to describe the trends, with $\Delta C_{\text{OH}} = (17 \pm 11) \%$ and $\Delta C_{\text{HO}_2} = (31.6 \pm 4.4) \%$ increase per mbar air (uncertainties quoted to 2σ). Presented here are the first direct measurements of the FAGE calibration constants as a function of external pressure (440–1000 mbar) in a controlled environment using the University of Leeds HIRAC chamber (Highly Instrumented Reactor for Atmospheric Chemistry). Two methods were used: the temporal decay of hydrocarbons for calibration of OH, and the kinetics of the second-order recombination of HO₂ for HO₂ calibrations. Over comparable conditions for the FAGE cell, the two alternative methods are in good agreement with the conventional method, with the average ratio of calibration factors (conventional:alternative) across the entire pressure range $C_{\text{OH}(\text{conv})}/C_{\text{OH}(\text{alt})} = 1.19 \pm 0.26$ and $C_{\text{HO}_2(\text{conv})}/C_{\text{HO}_2(\text{alt})} = 0.96 \pm 0.18$ (2σ). These alternative calibration methods currently have comparable systematic uncertainties than the conventional method: $\sim 28 \%$ and $\sim 41 \%$ for the alternative OH and HO₂ calibration methods respectively compared to 35 % for the H₂O vapour photolysis method; ways in which these can be reduced in the future are discussed. The good agreement between the very different methods of calibration leads to increased confidence in HO_x field measurements and particularly in aircraft based HO_x measurements, where there

AMTD

7, 7963–8011, 2014

Pressure dependent HO_x calibrations

F. A. F. Winiberg et al.

Title Page

Abstract

Introduction

Conclusions

References

Tables

Figures



Back

Close

Full Screen / Esc

Printer-friendly Version

Interactive Discussion



are substantial variations in external pressure, and assumptions are made regarding loss rates on inlets as a function of pressure.

1 Introduction

Short-lived free radicals play a crucial role in determining the composition of the atmosphere. The catalytic cycle of HO_x (= OH + HO₂) radicals is of central importance to tropospheric chemistry. OH acts as the primary daytime oxidant, initiating the degradation of most trace gases thereby controlling their atmospheric concentrations and lifetimes. The short lifetime of the radicals generate HO_x concentrations which are uninfluenced by transport, therefore reproducing observed HO_x concentrations can be an excellent test of any chemical model (Heard and Pilling, 2003). However, it should be mentioned that agreement between measured and modelled [HO_x] could be fortuitous as both sources and sinks of HO_x radicals could be simultaneously under or overestimated. The development of detection techniques that permit the speciation of a wider range of atmospheric components (e.g. VOCs and aerosols), together with OH reactivity measurements, can help to further constrain modelling studies, and reduce the potential for the coincidental agreement. OH has been detected by long path differential absorption spectroscopy (DOAS) in the field (Brauers et al., 1996; Dorn et al., 1996) and in the SAPHIR chamber (Schlosser et al., 2009) and chemical ionisation mass spectrometric techniques (CIMS) have also been used in field observations (Eisele and Tanner, 1991; Berresheim et al., 2002; Sjostedt et al., 2007; Kukui et al., 2008). However, a majority of field measurements have been made using laser induced fluorescence (LIF) spectroscopy and intercomparisons exist which have validated the technique against DOAS and CIMS in both chamber (Schlosser et al., 2007, 2009; Fuchs et al., 2012) and field environments including aircraft based measurements (Eisele et al., 2001, 2003). Low concentrations and potential interferences (Fuchs et al., 2011; Mao et al., 2012; Whalley et al., 2013) make HO_x measurements challenging. In addition, most HO_x detection methods are not absolute and hence calibration is required.

Pressure dependent HO_x calibrations

F. A. F. Winiberg et al.

Title Page

Abstract

Introduction

Conclusions

References

Tables

Figures



Back

Close

Full Screen / Esc

Printer-friendly Version

Interactive Discussion



Pressure dependent HO_x calibrations

F. A. F. Winiberg et al.

Title Page

Abstract

Introduction

Conclusions

References

Tables

Figures



Back

Close

Full Screen / Esc

Printer-friendly Version

Interactive Discussion



Fluorescence Assay by Gas Expansion, FAGE, is a low pressure LIF technique commonly used for the detection of OH and HO₂ radicals (Heard (2006) and references therein). The low concentrations of ambient OH ($\sim 10^6$ molecule cm⁻³) require a viable measurement technique to discriminate between laser scattered light and small signal levels. Originally this was attempted by exciting OH to the first vibrational level in the A state at 282 nm ($A^2\Sigma^+$ ($v' = 1$) \leftarrow $X^2\Pi_i$ ($v'' = 0$)) OH transition) and observing off-resonant fluorescence at ~ 308 nm using an interference filter to help discriminate against scattered laser radiation (Davis et al., 1976). Although non-resonant LIF has been successful in stratospheric applications (Wennberg et al., 1994), in the troposphere 282 nm photolysis of ozone (and subsequent reaction of O(¹D) with water vapour) generates an unacceptably high interfering OH signal, and on-resonant LIF with excitation at 308 nm is used instead. Expanding the sample through a pinhole to low pressure (~ 2 – 3 mbar) increases the fluorescence lifetime of the A state beyond the laser scatter pulse, allowing for temporal discrimination against the resonant 308 nm excitation pulse ($A^2\Sigma^+$ ($v' = 0$) \leftarrow $X^2\Pi_i$ ($v'' = 0$)) OH transition). Injection of an OH scavenger (e.g. C₃F₆) allows quantification of any laser generated OH interference (Mao et al., 2012; Novelli et al., 2014). HO₂ is converted into OH via reaction with added NO:



and the resultant OH is detected in the same way. Detection of OH and HO₂ either simultaneously or in series can be achieved using the same LIF detection axis (measurements in series, Creasey et al., 2003), with two separate LIF axes within the same cell (simultaneous, Stevens et al., 1994) or with two separate detection cells (simultaneous, Whalley et al., 2010).

LIF is a very sensitive, but non-absolute detection method and therefore each channel of the instrument needs to be calibrated. The Vacuum–Ultra–Violet (VUV) photolysis of H₂O vapour was originally developed for the calibration of HO_x measurement instruments in the 1990s (Aschmutat et al., 1994; Schultz et al., 1995; Heard and Pilling, 2003). Since then the methodology has become the HO_x measurement community standard. Upon the photolysis of a known H₂O vapour concentration (in synthetic air at

atmospheric pressure) by a mercury (Hg) pen-ray lamp at 184.9 nm, OH and HO₂ are produced in unity ratio (Fuchs et al., 2011) via Reactions (R2) and (R3) (Schultz et al., 1995):



The radicals are then sampled by the HO_x instrument at atmospheric pressure; the concentrations of OH and HO₂ produced can be determined using Eq. (1):

$$[\text{OH}] = [\text{HO}_2] = [\text{H}_2\text{O}] \sigma_{\text{H}_2\text{O},184.9\text{nm}} \Phi_{\text{OH}} F_{184.9\text{nm}} \Delta t \quad (1)$$

where [H₂O] is the water vapour concentration, $\sigma_{\text{H}_2\text{O},184.9\text{nm}}$ is the known absorption cross-section of H₂O vapour at 184.9 nm ($(7.22 \pm 0.22) \times 10^{-20} \text{ cm}^2 \text{ molecule}^{-1}$, Cantrell et al., 1997; Creasey et al., 2000), Φ_{OH} ($= \Phi_{\text{HO}_2} = 1$) is the photodissociation quantum yield of OH and HO₂ (Fuchs et al., 2011), $F_{184.9\text{nm}}$ is the photon flux of 184.9 nm light and Δt is the exposure time of the air to the Hg lamp output. There are two main methodologies used for obtaining the product $F_{184.9\text{nm}} \Delta t$ in Eq. (1). In the first, the two parameters are measured separately, $F_{184.9\text{nm}}$ using a calibrated phototube and Δt using knowledge of the volumetric flowrate and geometric parameters of the flow-tube (Stevens et al., 1994). In the other, a chemical actinometer is used to obtain the product directly, with both O₂ and N₂O photolysis at 184.9 nm used to generate either O₃ or NO which is subsequently detected using commercial analysers, with good sensitivity (Creasey et al., 1997a; Hofzumahaus et al., 1997; Heard and Pilling, 2003; Faloon et al., 2004). There are two main methods for delivery of the OH radicals to the FAGE inlet at atmospheric pressure, either using a laminar or turbulent flow-tube. In the laminar flow regime there is a radial gradient in the OH concentration for which the so-called profile factor (P) has to be quantified (Holland et al., 1995; Creasey et al., 1997a), whereas in turbulent flow system in which the radial OH concentration is constant except very close to the walls.

Pressure dependent HO_x calibrations

F. A. F. Winiberg et al.

Title Page

Abstract

Introduction

Conclusions

References

Tables

Figures



Back

Close

Full Screen / Esc

Printer-friendly Version

Interactive Discussion



**Pressure dependent
HO_x calibrations**

F. A. F. Winiberg et al.

Title Page

Abstract

Introduction

Conclusions

References

Tables

Figures



Back

Close

Full Screen / Esc

Printer-friendly Version

Interactive Discussion



Alternative calibration methods have also been developed, but typically not deployed in the field, and examples of these will be employed in the current study. A detailed evaluation of calibration techniques has been presented by Dusanter et al. (2008). In some of the earliest field measurements, Hard et al. (1995) developed a calibration method based on hydrocarbon decays. The concentration of a hydrocarbon with a known and well-characterised rate coefficient for reaction with OH, k (in this case 1,3,5-trimethylbenzene), was measured as a function of time using gas chromatography, allowing determination of all the parameters in Eq. (2) with the exception of [OH]. The rate of loss of a hydrocarbon (HC) through reaction with OH is given by Eq. (2):

$$-\frac{d[\text{HC}]}{dt} = k[\text{OH}][\text{HC}] \quad (2)$$

This methodology has also been applied more recently to FAGE validation measurements in the EUPHORE chamber (Bloss et al., 2004).

For HO₂ the well defined second order recombination rate coefficient for Reaction (R4) can be used to determine [HO₂], where, for a second order reaction the half life of the decay is related to the initial starting concentration.



In a short set of experiments, Pilling et al. (2005) generated HO₂ from the photolysis of formaldehyde in the EUPHORE chamber and observed the second order HO₂ decay with a FAGE instrument. The decays were in good agreement with the calibrated HO₂ measurements, but no systematic studies have been undertaken using this reaction as a calibration method.

The deployment of the FAGE technique for aircraft-based measurements (Faloona et al., 2000; Commane et al., 2010; Martinez et al., 2010) raises two issues. First, the need to sample air from outside of the boundary layer of the aircraft fuselage requires a significant length of flowtube before the gas sample is interrogated by the laser beam. Secondly, the pressure in the FAGE cell will vary as the aircraft changes altitude (e.g.

**Pressure dependent
HO_x calibrations**

F. A. F. Winiberg et al.

Title Page

Abstract

Introduction

Conclusions

References

Tables

Figures



Back

Close

Full Screen / Esc

Printer-friendly Version

Interactive Discussion



0–7 km, 1.3–2.8 mbar internal cell pressure range, from Commane et al., 2010), altering the instrumental sensitivity (Commane et al., 2010; Martinez et al., 2010) owing to changes, for example, in the nature of the initial expansion into the FAGE apparatus. The current design of the flowtube calibration method is limited to delivering the calibrated [OH] at atmospheric pressure, however, by using different nozzle pinhole diameters (typically 0.2–1.0 mm) it is possible to alter the pressure in the FAGE cell over the range typically encountered during a flight. Importantly, this method does not compensate for the changing pressure differential across the inlet nozzle experienced during a flight and what effect this might have on the expanding gas before it reaches the FAGE cell. The possible change in radical surface losses due to the change in inlet pinhole diameter are also assumed to be negligible.

Potential systematic uncertainties around the application of calibrations performed at atmospheric pressure to HO_x data obtained whilst sampling from different pressures (e.g. in flight) highlight the need to obtain calibrations at relevant external pressures. Martinez et al. (2010) have investigated the effect of external pressure on instrument sensitivity by calibrating during flight, reporting an increase in the instrument sensitivity to OH in the free troposphere, compared to the boundary layer. It was not concluded whether this was an effect of the calibration source used (conventional H₂O vapour photolysis) or the instrument itself, however the increase was not characterised by the conventional calibrations performed on the ground before the flight.

We report here an intercomparison of HO_x calibrations based on the conventional flow-tube methodology, using different inlet nozzle diameters to vary the internal fluorescence cell pressure, with two alternative calibration methods. Analysis of the decays of hydrocarbons were used to determine [OH], while analysis of the kinetics of HO₂ decay by self reaction following the photolysis of formaldehyde to determine [HO₂]. The studies took place in the Highly Instrumented Reactor for Atmospheric Chemistry (HIRAC), which is a custom-built atmospheric simulation chamber providing the unique ability to simultaneously vary pressure and temperature whilst measuring the short-lived free radical species OH, HO₂ and NO₃ (Glowacki et al., 2007a; Malkin,

2010; Malkin et al., 2010). These features make HIRAC ideally suited to the study of the kinetics and mechanisms of atmospherically relevant reactions and the calibration, validation and development of atmospheric measurement instrumentation.

2 HIRAC and FAGE instrumentation

2.1 HIRAC

Experiments were conducted in HIRAC, a stainless steel chamber with a total volume of 2.25 m³ and total internal surfaces of 13 m² ($S/V \sim 5.8 \text{ m}^{-1}$). The chamber could operate over a wide range of pressures (10–1000 mbar), with multiple access ports used to connect an array of instrumentation and monitoring equipment (pressure gauges, thermocouples etc.). Further details on the construction can be found in Glowacki et al. (2007a) and Malkin et al. (2010).

The photolysis lamps, housed in eight quartz tubes mounted radially inside the reactive volume, were used to initiate photochemistry. The lamps were interchangeable depending on the target molecules; lamps, with primary emissions centred at 254 and 290 nm (GE Optica, GE55T8/HO and Philips, TL40W/12 RS), were used for the alternative OH and HO₂ calibration methods respectively (Sects. 3.2 and 3.3). The output of the lamps was temperature dependent outside of a narrow temperature range ($\sim 35\text{--}39^\circ\text{C}$) and so the housings were flushed with N₂ to regulate the temperature and remove photolabile species. A photolysis lamp induced chamber temperature increase of $\sim 2 \text{ K}$ was seen over the course of a typical experiment ($< 40 \text{ min}$), and was therefore considered negligible compared to the temperature of the chamber on any given day ($293 \pm 5 \text{ K}$).

Investigations into radical gradients across the HIRAC chamber have been conducted using direct FAGE measurements of OH produced from both photolytic (methyl nitrite) and non-photolytic (O₃+ *trans*-2-butene) sources using an extended inlet (800 mm) to probe across the chamber diameter. No significant OH radical gradient

Pressure dependent HO_x calibrations

F. A. F. Winiberg et al.

Title Page

Abstract

Introduction

Conclusions

References

Tables

Figures



Back

Close

Full Screen / Esc

Printer-friendly Version

Interactive Discussion



**Pressure dependent
HO_x calibrations**

F. A. F. Winiberg et al.

Title Page

Abstract

Introduction

Conclusions

References

Tables

Figures



Back

Close

Full Screen / Esc

Printer-friendly Version

Interactive Discussion



was observed until the FAGE sampling nozzle was ~ 200 mm from the wall and a maximum $\sim 15\%$ decrease (compared to the centre of the chamber) was seen when the sampling inlet was flush with the chamber walls. Other than close to the walls, the lack of gradient in OH radicals from both photolytic and non-photolytic sources provides direct evidence of the homogeneity of the lamp radiation profile and efficacy of mixing in the chamber, whilst showing that the standard FAGE inlet (280 mm, Sect. 2.2) samples well into the homogeneous area.

Ozone was monitored using a UV photometric O₃ analyser (Thermo Electron Corporation 49C, detection limit (d.l.) = 1.0 ppbv at 60 s averaging). The O₃ analyser had been calibrated using a commercial ozone primary standard (Thermo Electron Corporation 49i-PS) and an intercomparison with the FTIR within HIRAC was linear (Glowacki et al., 2007a). A chemiluminescence NO_x analyser (TEC 42C, d.l. = 50 pptv at 60 s averaging) was used to determine that levels of NO_x (= NO + NO₂) were characteristically below the detection limit of the apparatus.

A calibrated gas chromatography instrument with flame ionisation detector (GC-FID, Agilent Technologies, 6890N) was used for the online detection of reactants (Sect. 3.2) using an evacuated sampling loop into which gas from the chamber was expanded. The GC was fitted with a CP-SIL-5 column (50 m, 0.32 mm, 5 μ m) using He carrier gas and a constant oven temperature (40–75 °C depending on the hydrocarbon being detected) and was able to provide hydrocarbon measurements on a 2–6 min time resolution. Supporting measurements of iso-butene and (CH₃)₃COOH were made via a long path FTIR absorption facility. The FTIR spectrometer (Bruker, IFS/66) was coupled to a Chernin-type multipass cell (Glowacki et al., 2007b) and spectral resolution was maintained at 1 cm⁻¹ across all experiments, using 32 co-added spectra for a 30 s time resolution.

Calibration experiments were conducted over a pressure range of 440–1000 mbar in an Ultra-High Purity (UHP) 1 : 4 synthetic air mix of O₂ (BOC, zero-grade, > 99.999 %) and N₂ (BOC, zero-grade, > 99.998 %) to match the range of pressures from the pin-hole calibration method (Sect. 3.1). The UHP gases help maintain low H₂O vapour

**Pressure dependent
HO_x calibrations**

F. A. F. Winiberg et al.

Title Page

Abstract

Introduction

Conclusions

References

Tables

Figures



Back

Close

Full Screen / Esc

Printer-friendly Version

Interactive Discussion



Concentrations of HO₂ were measured simultaneously in a second detection axis ~ 300 mm downstream of the OH detection axis. High purity NO (BOC, N2.5 Nitric Oxide) was added ~ 20 mm before the HO₂ detection axis into the centre of the FAGE cell in the direction of gas flow through 1/8" stainless steel tubing at a rate of 5 sccm (Brooks 5850S) converting HO₂ to OH.

Recently published material on the conversion of certain RO₂ radicals to OH upon reaction with NO in FAGE detection cells (Fuchs et al., 2011; Whalley et al., 2013) have shown a significant enhancement of the HO₂ signal in the presence of RO₂ derived from certain hydrocarbons. These effects have been thoroughly studied using a range of different hydrocarbons for the HIRAC FAGE apparatus and will be the subject of a further publication. Any interference from RO₂ radicals produced during the alternative calibration methods was demonstrated to be negligible under the conditions of these experiments (Winiberg, 2014).

Experiments with the HIRAC FAGE instrument used a new medium pulse repetition frequency (PRF) laser light source (= 200 Hz), with a different light delivery method to the detection cells, compared to that described by Glowacki et al. (2007a). The previously used JDSU Nd:YAG pumped Sirah Cobra Stretch system (PRF = 5 kHz), focussed the frequency doubled 308 nm output into fibre optic cables (10 m, Oz Optics) which were then attached directly to the FAGE cell arms via collimators (Oz Optics). Using the new Litron Nd:YAG (NANO-TRL-50-250) pumped Lambda Physik (LPD3000) dye laser system (PRF = 200 Hz), the high laser pulse energies were found to burn the ends of the fibre optic cables, and hence direct light delivery was applied using a combination of mirrors, lenses and irises was used to direct and shape the beam to the OH and HO₂ detection regions, as shown in the top-down schematic of the modified HIRAC FAGE instrument displayed in Fig. 2.

The UV light exiting the dye laser was split with a quartz flat (Fig. 2, Q1) to direct ~ 5 % of the laser light towards the reference cell (where OH was generated continuously from a hot wire filament in water saturated air), which enabled precise tuning of the laser wavelength to the maxima of the OH Q₁ (2) branch (within 98 %). The

**Pressure dependent
HO_x calibrations**

F. A. F. Winiberg et al.

Title Page

Abstract

Introduction

Conclusions

References

Tables

Figures



Back

Close

Full Screen / Esc

Printer-friendly Version

Interactive Discussion



remaining light was aligned through the OH and HO₂ cells sequentially using a series of 308 nm centred turning optics (M1 – M4, CVI Laser Optics, Melles Griot). A lens was used (L1, $f = 100$ mm) in conjunction with an iris (I2), to help transmit the laser beam through both detection cells, avoiding collisions with any internal surfaces. Fluctuations in laser power were accounted for using a linear response UV sensitive photodiode (UDT-555UV, Laser Components UK) at the exit arm of the HO₂ detection axis to normalise the LIF signal. Both laser systems provided between 5–7 and 2–3 mW of 308 nm light to the OH and HO₂ detection axes respectively.

The OH fluorescence was collected orthogonal to the gas flow onto electronically gated Channeltron PhotoMultiplier tubes (CPM, Perkin Elmer, C943P) via a series of imaging lenses and a narrow bandpass filter (Barr Associates, 308.8±5.0 nm). A spherical concave back reflector was positioned underneath the cell, opposite the detection optics, to optimise light collection onto the CPM. To avoid detector saturation, the CPM was gated (i.e. switched off) for the duration of the laser pulse using a modified gating unit based on the original design by Creasey et al. (1997a). Signals from the CPM were analysed using photon counting cards (Becker and Hickl PMS-400A).

A new OH scavenger system was installed to help discriminate between OH sampled from the chamber and laser generated OH in the fluorescence cells due to the higher pulse energies associated with the 200 Hz PRF laser system (1×10^{14} compared to 5×10^{12} photons pulse⁻¹ cm⁻² at 5 kHz for laser power = 8 mW). A mixture of isobutane (20% in N₂) was injected ~ 40 mm inside the inlet pinhole into the central flow (Fig. 1), through a 1/8" internal diameter stainless steel pipe at a rate of ~ 20 sccm, reacting with the sampled OH before reaching the detection axis. The laser generated OH was probed within the same laser pulse (12 ns) and hence was not suppressed by the scavenger injection. Multiple photolysis of the same gas sample was avoided as the residence time in the laser pulse cross section (~ 0.5 cm²) was calculated at ~ 0.4 ms, compared to a laser pulse every 5 ms at 200 Hz PRF (assuming plug flow at a 6 slm ambient sampling rate). Neither a pressure increase nor attenuation of UV light was detected during the scavenger injection process at this flow rate and dilution.

3 Calibration procedures

3.1 Conventional H₂O vapour photolysis calibration

The requisite equation for calibration of FAGE by water vapour photolysis was given as:

$$[OH] = [HO_2] = [H_2O]\sigma_{H_2O,184.9nm}\Phi_{OH}F_{184.9nm}\Delta t \quad (1)$$

and the principles were outlined above in Sect. 1. A schematic diagram of the H₂O vapour photolysis calibration source is presented in Fig. 3, consisting of a square cross section flow tube (12.7 mm × 12.7 mm × 300 mm) through which 40 slm of humidified air (BOC, BTCA 178) was passed resulting in a turbulent flow regime (Reynolds number ≥ 4000). The air was humidified by passing a fraction of the total air flow through a deionised water bubbler system and [H₂O] was measured using a dew-point hygrometer (CR4, Buck Research Instrument) prior to the flow tube. The collimated 184.9 nm output of a mercury pen-ray lamp (LOT-Oriel, Hg-Ar) was introduced to the end of the main flow tube, photolysing H₂O vapour (Reactions R2 and R3). The gas output from the flow tube was directed towards the FAGE sampling inlet, where the overflow of the FAGE sample volume from the flow tube stopped the impingement of ambient air. A range of HO_x concentrations were produced by changing both the H₂O vapour concentration and the mercury lamp photon flux.

The flux of 184.9 nm light, $F_{184.9nm}$, was varied by altering the Hg lamp supply current and was dependent on the specific mercury lamp employed along with the lamp temperature and orientation (Hofzumahaus et al., 1997; Creasey et al., 2000; Dusanter et al., 2008). To this end, determinations of the flux from the specific mercury lamp used in the calibrations described in this work were made in situ for lamp supply currents between 0.2 and 3.0 mA using the N₂O actinometry method described in detail in a number of publications (Edwards et al., 2003; Heard and Pilling, 2003; Faloon et al., 2004; Glowacki et al., 2007a; Whalley et al., 2007). The exposure time of the air to the

Title Page

Abstract

Introduction

Conclusions

References

Tables

Figures



Back

Close

Full Screen / Esc

Printer-friendly Version

Interactive Discussion



184.9 nm light, Δt , was calculated as a function of the known velocity of the air and the cross section of the photolysis region.

Various cell conditions and their effect on the sensitivity to OH and HO₂ have been reported in the literature (Faloona et al., 2004; Martinez et al., 2010; Regelin et al., 2013). Here, instrument sensitivity as a function of internal cell pressure has been determined for the HIRAC FAGE instrument, using a combination of both laser sources (Table 1). Different internal cell pressures (1.8–3.8 mbar) were achieved by changing the diameter of the FAGE inlet pinhole between 0.5–1.0 mm.

3.2 Hydrocarbon decay method – OH calibration

Hydrocarbons ($0.5\text{--}2.0 \times 10^{13}$ molecule cm⁻³) and the OH precursor, *tert*-butylhydroperoxide (TBHP, Sigma Aldrich ~ 40 % in H₂O, 2.0×10^{13} molecule cm⁻³) were introduced to the chamber before the lamps were switched on initiating the decay experiment. OH was produced directly from the photolysis of TBHP at $\lambda = 254$ nm and is, as far as we are aware, the first chamber experiment to use TBHP photolysis as a source of NO_x free OH. Upon illumination of the chamber, rapid photolysis led to an instantaneous peak $[\text{OH}] \sim 10^7$ molecule cm⁻³ before OH decayed away over ~ 30 min as the TBHP was removed by photolysis, whilst OH was removed through reaction with TBHP ($k_{\text{OH}}(296\text{K}) = (3.58 \pm 0.54) \times 10^{-12}$ cm³ molecule⁻¹ s⁻¹, Baasandorj et al., 2010) and the selected hydrocarbon. The alternative OH calibrations presented here were conducted for the HIRAC based FAGE instrument operating at 200 Hz PRF only.

Cyclohexane (> 99 %, Fisher Scientific), *n*-pentane (> 99 %, Fisher Scientific) and iso-butene (99 %, Sigma Aldrich), were employed as the hydrocarbons in this study due to their sufficiently fast and well known rates of reaction with OH to provide a quantifiable decay compared to chamber dilution. The rate coefficient for OH with iso-butene has been evaluated by IUPAC as $k_{\text{OH}}(298\text{K}) = (51 \pm 12) \times 10^{-12}$ cm³ molecule⁻¹ s⁻¹ (IUPAC, 2007), and rate coefficients for the reaction of OH with cyclohexane and *n*-pentane have been reviewed by Calvert et al. (2008) as $k_{\text{OH}}(298\text{K}) = (6.97 \pm 1.39)$

Title Page

Abstract

Introduction

Conclusions

References

Tables

Figures



Back

Close

Full Screen / Esc

Printer-friendly Version

Interactive Discussion



**Pressure dependent
HO_x calibrations**

F. A. F. Winiberg et al.

Title Page

Abstract

Introduction

Conclusions

References

Tables

Figures

I◀

▶I

◀

▶

Back

Close

Full Screen / Esc

Printer-friendly Version

Interactive Discussion



and $(3.96 \pm 0.76) \times 10^{-12} \text{ cm}^3 \text{ molecule}^{-1} \text{ s}^{-1}$ respectively (all quoted to $\pm 2\sigma$). Whilst alkanes are known to have a pressure independent rate coefficient for OH reactions, the reactions of OH with alkenes occur predominantly by addition, a process which is pressure dependent, with the rate coefficient increasing with pressure up to the high pressure limit where the addition of OH is the rate determining step (Pilling and Seakins, 1995). A study by Atkinson and Pitts (1975) into the reaction of various small chain alkenes showed no pressure dependence for propene over 25–100 Torr of argon, therefore the reaction of OH with the larger iso-butene molecule is presumed to be pressure independent above 100 Torr (Atkinson, 1986; IUPAC, 2007). To confirm this, a relative rate study in air was conducted using isoprene as a reference ($k_{\text{OH}}(298\text{K}) = (1.00 \pm 0.14) \times 10^{-10} \text{ cm}^3 \text{ molecule}^{-1} \text{ s}^{-1}$, IUPAC, 2007). Both direct and relative rate studies have shown that the reaction of isoprene and OH is at the high pressure limit above 100 Torr (Campuzano-Jost et al., 2004; Park et al., 2004; Singh and Li, 2007). Figure 4 shows that there is no significant pressure dependence in k_{OH} for OH + iso-butene over the 250–1000 mbar pressure range within the uncertainty of the experiment ($\sim 25\%$, $\pm 2\sigma$) and that the measured rate coefficient, $k_{\text{OH}}(298\text{K}) = (4.87 \pm 0.83) \times 10^{-11} \text{ cm}^3 \text{ molecule}^{-1} \text{ s}^{-1}$, is in good agreement with the literature values $(5.07 \pm 0.51) \times 10^{-11} \text{ cm}^3 \text{ molecule}^{-1} \text{ s}^{-1}$ for IUPAC (Atkinson, 2003; IUPAC, 2007).

The hydrocarbon decay method relies on the loss of hydrocarbon being solely due to reaction with OH and hence the effects of O₃ and NO₃ as reagents must be considered as both are important in the oxidation of alkenes. Before photolysis, O₃ and NO_x were measured to be around the instrumental detection limits (0.5 and 0.050 ppb at 60 s averaging respectively) using commercial analysers (details given in Sect. 2.1). Upon photolysis a slow increase in O₃ and NO₂ was observed, to a maximum of ~ 40 and ~ 20 ppbv respectively. The [NO₃] upper limit was estimated at ~ 0.32 pptv using a simple steady-state approximation, where NO₃ production was controlled purely by O₃ + NO₂ → NO₃ (Atkinson et al., 2004) and loss by photolysis ($j(\text{NO}_2) = 1.93 \pm 0.10$, Glowacki et al., 2007a). Under these conditions it was estimated that $> 98\%$ of the

loss of iso-butene would be due to OH and not O₃ or NO₃ where $k_{O_3} = (1.13 \pm 0.33) \times 10^{-17} \text{ cm}^3 \text{ molecule}^{-1} \text{ s}^{-1}$ and $k_{NO_3} = (3.4 \pm 1.0) \times 10^{-13} \text{ cm}^3 \text{ molecule}^{-1} \text{ s}^{-1}$ (Calvert et al., 2000).

3.3 Formaldehyde photolysis – HO₂ calibration

Formaldehyde was produced by direct heating of paraformaldehyde powder in a glass finger (Sigma Aldrich, 99%) and was introduced in a flow of nitrogen into the chamber at concentrations $\sim 2 \times 10^{13} \text{ molecule cm}^{-3}$ (determined manometrically). The chamber was irradiated (lamps: Philips TL40W/12 RS) resulting in an almost instantaneous HO₂ signal. Once an approximately steady state HO₂ concentration was achieved, the photolysis lamps were turned off and the decay of HO₂ was monitored by FAGE for $\sim 120 \text{ s}$ until near background signals levels were reached. The measurement of HO₂ decays was repeated up to five times before the laser wavelength was scanned to the offline position. Therefore five individual C_{HO₂} determinations could be achieved from one chamber fill, with the limiting factor being the increased complexity of the reaction mixture after repeated photolysis cycles. After five decays, the analysis often exhibited evidence of secondary chemistry starting to distort the HO₂ signal profiles, showing non-linearity in second order plots. The absence of OH in these experiments was confirmed by simultaneous measurement of OH in the OH fluorescence cell, giving signals below the detection limit ($1.6 \times 10^6 \text{ molecule cm}^{-3}$ for 60 s averaging for the 200 Hz PRF laser system).

Formaldehyde concentrations were kept low ($< 3 \times 10^{13} \text{ molecule cm}^{-3}$) to avoid removal of HO₂ via reaction with HCHO, ensuring that the loss of HO₂ occurs predominantly via self-reaction and wall loss (Sect. 4.2). The HO₂ calibrations were conducted for the HIRAC based FAGE instrument operating at 200 Hz PRF and the aircraft based FAGE instrument operating at 5 kHz PRF. The chamber mixing fans were used for the majority of calibration data sets discussed here, representative of a typical experimental homogeneous gas mixture. A series of experiments were conducted without the

Pressure dependent HO_x calibrations

F. A. F. Winiberg et al.

Title Page

Abstract

Introduction

Conclusions

References

Tables

Figures



Back

Close

Full Screen / Esc

Printer-friendly Version

Interactive Discussion



mixing fans to probe the HO₂ recombination and wall loss kinetics using the aircraft based FAGE instrument, and these are discussed in greater detail in Sects. 4.2 and 5.3.

4 Data analysis

4.1 Hydrocarbon decay

Figure 5 shows the hydrocarbon decay for iso-butene at 750 mbar and 294 K measured by GC-FID and FTIR. Using the Guggenheim method (Guggenheim, 1926; Bloss et al., 2004) the pseudo-first-order rate coefficient (k') for the hydrocarbon removal was calculated using Eq. (3):

$$k' = \frac{\ln([\text{HC}]_1/[\text{HC}]_2)}{(t_2 - t_1)} \quad (3)$$

where $[\text{HC}]_1$ and $[\text{HC}]_2$ are the concentrations of the hydrocarbon at time t_1 and t_2 respectively. The mean $[\text{OH}]$ between t_1 and t_2 , was calculated using Eq. (4):

$$[\text{OH}] = \frac{(k' - k_{\text{Dil}})}{k_{\text{OH}}} \quad (4)$$

where k_{Dil} is the dilution rate of the measured $[\text{HC}]$ due to continuous sampling from instrumentation (e.g. FAGE). Bloss et al. (2004) found the Guggenheim method to be most effective when smoothing the inferred $[\text{OH}]$ over five $[\text{HC}]$ measurements (i.e. consider ten measurements taken at times $t_1 - t_{10}$. $[\text{OH}]$ at t_5 would take $[\text{HC}]_1$ and $[\text{HC}]_5$, t_6 : $[\text{HC}]_2$ and $[\text{HC}]_6$ etc.). Due to the short experiment time (20–30 min) and the 2–6 min time resolution on the GC measurements, this smoothing was not possible. For iso-butene, FTIR measurements were taken every 30 s, and these were typically found to be in excellent agreement with the GC-FID measured HC decays, as shown

Pressure dependent HO_x calibrations

F. A. F. Winiberg et al.

Title Page

Abstract

Introduction

Conclusions

References

Tables

Figures

◀

▶

◀

▶

Back

Close

Full Screen / Esc

Printer-friendly Version

Interactive Discussion



**Pressure dependent
HO_x calibrations**

F. A. F. Winiberg et al.

Title Page

Abstract

Introduction

Conclusions

References

Tables

Figures

I◀

▶I

◀

▶

Back

Close

Full Screen / Esc

Printer-friendly Version

Interactive Discussion



the iso-butane scavenger (20 % in N₂) was injected into the FAGE cell for ~ 90 s at ~ 20 sccm. Typically 3–4 scavenger injections were completed per experiment and an empirical fit to the averaged signals was used to correct the measured OH signal from TBHP laser photolysis, shown here in Fig. 6b compared to the inferred [OH] from the GC-FID. The type of fitting parameter (e.g. linear or exponential) was judged depending on the quality of data.

The calibration procedure was completed by plotting the OH signals, normalised for laser power, measured by FAGE as a function of the calculated OH concentrations from the hydrocarbon decays producing a calibration plot with C_{OH}, in units of counts cm³ s⁻¹ mW⁻¹ molecule⁻¹, as the gradient. A typical calibration plot is shown in Fig. 7; produced using the decay of iso-butene at 1000 mbar chamber pressure (see caption for detailed operating conditions).

4.2 Formaldehyde photolysis

Calibration of the HO₂ detection cell required only the generation of HO₂ radicals in the HIRAC chamber, and a time-dependent measurement of their subsequent recombination using the FAGE instrument once the photolysis lamps were extinguished. Upon photolysis in air (lamps: Philips TL40W/12 RS), HCHO produced H + HCO and H₂ + CO (Reaction R9) in approximately a 60 : 40 ratio (Reactions R8 and R9). Under the conditions in HIRAC, HCO reacted with O₂ to give HO₂ + CO (Reaction R10) and the H atom produced in Reaction (R8) reacted with O₂ to give HO₂ (Reaction R11). The loss of HO₂ was characterised by the competing bimolecular and termolecular self-reactions

(Reactions R12 and R13) and a first order wall loss parameter (Reaction R14):

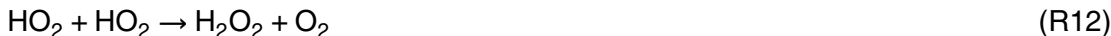
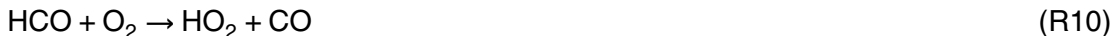

Therefore the rate of loss of HO₂ is given by:

$$10 \quad \frac{d[\text{HO}_2]}{dt} = - \left(k_{\text{loss}}[\text{HO}_2] + 2k_{\text{HO}_2+\text{HO}_2}[\text{HO}_2]^2 \right) \quad (5)$$

where $k_{\text{HO}_2+\text{HO}_2}$ is the HO₂ recombination rate coefficient; the sum of the pressure independent (Reaction R12) and dependent (Reaction R13) rate coefficients as determined by IUPAC (2007). Solving analytically for [HO₂]_t at a given time, t , integration of Eq. (5) becomes:

$$15 \quad \frac{1}{[\text{HO}_2]_t} = \left(\frac{1}{[\text{HO}_2]_0} + \frac{2 \cdot k_{\text{HO}_2+\text{HO}_2}}{k_{\text{loss}}} \right) \cdot e^{(k_{\text{loss}}t)} - \left(\frac{2 \cdot k_{\text{HO}_2+\text{HO}_2}}{k_{\text{loss}}} \right) \quad (6)$$

The [HO₂] in Eq. (6) is unknown but is related to the normalized HO₂ signals measured by FAGE, S_{HO_2} , and the instrument sensitivity to HO₂, C_{HO_2} , and therefore:

$$20 \quad \left(S_{\text{HO}_2} \right)_t = \left(\left(\frac{1}{\left(S_{\text{HO}_2} \right)_0} + \frac{2 \cdot k_{\text{HO}_2+\text{HO}_2}}{k_{\text{loss}} \cdot C_{\text{HO}_2}} \right) \cdot e^{(k_{\text{loss}}t)} - \left(\frac{2 \cdot k_{\text{HO}_2+\text{HO}_2}}{k_{\text{loss}} \cdot C_{\text{HO}_2}} \right) \right)^{-1} \quad (7)$$

Pressure dependent HO_x calibrations

F. A. F. Winiberg et al.

Title Page

Abstract

Introduction

Conclusions

References

Tables

Figures



Back

Close

Full Screen / Esc

Printer-friendly Version

Interactive Discussion



where $(S_{\text{HO}_2})_t$ and $(S_{\text{HO}_2})_0$ are the HO₂ signal at time t and $t = 0$ respectively.

The measured decay of S_{HO_2} using FAGE and the fit described by Eq. (7) are displayed in Fig. 8a for a typical experiment (aircraft FAGE instrument (5 kHz PRF), 1000 mbar, 298 K, < 10 ppm [H₂O], mixing fans on). Both k_{loss} and C_{HO_2} were determined by data fitting the S_{HO_2} decay using Eq. (7) with a Levenburg-Marquardt non-linear least squares algorithm, fixing the initial signal and $k_{\text{HO}_2+\text{HO}_2}$. The first ~ 100 s of data were used, ensuring analysis after an almost complete decay of S_{HO_2} . Fitting was improved by the inclusion of upper and lower bounds of ±10% for the $(S_{\text{HO}_2})_0$ into the fitting routine, which accounted for the uncertainty in the determination of $(S_{\text{HO}_2})_0$ (see Sect. 5.4.3).

For the experimental 350–1000 mbar pressure range at 0% H₂O vapour, $k_{\text{HO}_2+\text{HO}_2}$ was determined between $(2.00\text{--}2.85) \times 10^{-12} \text{ cm}^3 \text{ molecule}^{-1} \text{ s}^{-1}$, according to the recommendation given by IUPAC (2007). A calibration was conducted at $[\text{H}_2\text{O}]_{\text{vap}} = 7500 \text{ ppmv}$, to validate the calibration method at high water vapour concentrations, representative of the conventional H₂O vapour photolysis method. The $k_{\text{HO}_2+\text{HO}_2}$ therefore included a correction for the HO₂–H₂O vapour chaperone effect (Stone and Rowley, 2005) in accordance with the IUPAC recommendation (Atkinson et al., 2004). The wall loss rate, k_{loss} , was dependent on daily chamber conditions and was therefore determined as part of the fitting procedure along with C_{HO_2} , typically between 0.032–0.073 s^{−1} with an uncertainty of ±10% (2σ). Variations in the wall loss rates have implications for the uncertainty in C_{HO_2} derivation (Sect. 5.4).

5 Results and discussion

All results presented here were taken using the HIRAC FAGE instrument using LITRON Nd:YAG pumped dye laser light source operating at 200 Hz PRF, unless otherwise stated. Tabulated data from the alternative calibration methods are displayed in the

Supplement (Tables S1 and S2). All uncertainties displayed are quoted to $\pm 2\sigma$ and all regressions shown are empirical, unless otherwise stated.

5.1 Conventional H₂O vapour photolysis calibration

5.1.1 C_{OH} and C_{HO₂} as a function of internal cell pressure

5 The FAGE instrument sensitivity to OH (Fig. 9) and HO₂ (Fig. 10) was determined as a function of pressure using the H₂O vapour photolysis calibration method over the inlet pressure range between 1.8–3.8 mbar. Error bars in both figures are representative of the total uncertainty in the calibration (Sect. 5.4 for details). Constant laser power and [H₂O] were maintained throughout the calibration process (8 ± 1 mW and 4500 ± 600 ppmv respectively).

10 The linear regressions were used to describe the sensitivity as a function of fluorescence cell pressure for experiments conducted in HIRAC, and are a valid description of the data inside the 1.8–3.8 mbar pressure range only. The C_{OH} and C_{HO₂} datasets shown here were not conducted at the same time, but 6 months apart. This was due to the chronological order of the development of the alternative calibration techniques, during which time the FAGE pump-set was serviced, increasing the pumping capacity and generally lowering the internal cell pressures for each pinhole in the C_{OH} determination.

15 The fit displayed a greater increase in C_{HO₂} as function of pressure compared to C_{OH}, where $\Delta C_{OH} = (17.3 \pm 10.6) \%$ and $\Delta C_{HO_2} = (31.6 \pm 4.4) \%$ increase between 1.3–3.8 mbar. Altering the pinhole diameter could change the flow dynamics inside the instrument reducing NO mixing efficiency, and therefore HO₂ conversion efficiency, before the HO₂ cell. The decrease in C_{HO₂} at lower pressure has been reproduced in a more recent calibration of the HO₂ cell using the 5 kHz PRF laser source (slope = $(5.14 \pm 0.46) \times 10^{-9}$ counts cm³ molecule⁻¹ s⁻¹ mW⁻¹ mbar⁻¹), suggesting the process was not affected by changes in laser pulse energy.

Pressure dependent HO_x calibrations

F. A. F. Winiberg et al.

Title Page

Abstract

Introduction

Conclusions

References

Tables

Figures



Back

Close

Full Screen / Esc

Printer-friendly Version

Interactive Discussion



Pressure dependent HO_x calibrations

F. A. F. Winiberg et al.

Title Page

Abstract

Introduction

Conclusions

References

Tables

Figures



Back

Close

Full Screen / Esc

Printer-friendly Version

Interactive Discussion



The experimental parameters controlling the instrument sensitivity, C_{OH} , which are dependent upon pressure, are the OH concentration in the laser-excitation region, $[\text{OH}]_{\text{cell}}$, the fluorescence quantum yield following laser excitation to the OH $A^2\Sigma^+(\nu' = 0)$ excited state, ϕ_{fl} , and the fraction of the fluorescence decay which falls within the integrating gate of the photon counter, f_{gate} (Creasey et al., 1997b; Faloona et al., 2004). The OH concentration in the cell held at total density $[M]$ and the fluorescence quantum yield are given by Eqs. (9) and (10):

$$[\text{OH}]_{\text{cell}} = \chi[M] \quad (8)$$

$$\phi_{\text{fl}} = \frac{A}{(A + k_q[M])} \quad (9)$$

where χ is the mixing ratio of OH impinging at the pinhole (assuming no losses at the pinhole), A is the inverse of the radiative lifetime of OH and k_q is the rate coefficient for quenching of the excited $A^2\Sigma^+(\nu' = 0)$ (averaged appropriately over all quenching species). Assuming that $f_{\text{gate}} = 1$, then the overall pressure dependent term for instrument sensitivity to OH can be described as the product of Eqs. (8) and (9), shown here in Eq. (10):

$$[\text{OH}]_{\text{cell}} \times \phi_{\text{fl}} = \frac{\chi[M]A}{(A + k_q[M])} \quad (10)$$

At the limit of $[M] \rightarrow 0$, the product becomes $\chi[M]$ and C_{OH} is directly proportional to pressure ($[M]$), whereas at higher pressures when $k_q[M] \gg A$ (at 18 mbar the ratio is ~ 10) the product becomes $\sim \chi A/k_q$ and C_{OH} is independent of $[M]$, and thus depends only on the mixing ratio of OH. Hence the observation that C_{OH} increased non-linearly over pressures between 1.3–3.8 mbar in this study is consistent with the expected behaviour based purely on the balance between OH number density and rate of quenching.

Additional investigations into the FAGE instrument sensitivity to OH as a function of $[\text{H}_2\text{O}]_{\text{vap}}$ and laser power are discussed in detail in the Supplement.

5.2 Hydrocarbon decay calibration

Figure 7 shows a direct comparison of analysed data from the decay of iso-butene and H₂O vapour calibration method at ~ 3.80 mbar internal cell pressure (equivalent to 1000 mbar in HIRAC) using the 1.0 mm inlet pinhole and ~ 7 mW laser power. The C_{OH} was determined as $(2.1 \pm 1.1) \times 10^{-8}$ counts s⁻¹ molecule⁻¹ cm³ mW⁻¹, within error of the traditional H₂O vapour photolysis calibration (2σ) at the same pressure ($(2.62 \pm 0.91) \times 10^{-8}$ counts s⁻¹ molecule⁻¹ cm³ mW⁻¹). Error bars are representative of the total uncertainty at ±1σ. Additional example calibration plots for each hydrocarbon studied are included in the Supplement. Displayed in Fig. 9 is C_{OH} as a function of internal cell pressure using the HC decay calibration method, determined for iso-butene, cyclohexane and *n*-pentane. The HC decay calibration method was observed to be in agreement with the H₂O vapour photolysis calibration. The average of the ratio of calibration factors (conventional : alternative) was calculated for each alternative calibration point across the entire pressure range, $C_{\text{OH}(\text{conv})}/C_{\text{OH}(\text{alt})} = 1.19 \pm 0.26$, where C_{OH(conv)} was determined from the fit to the H₂O photolysis data.

A large variability in the C_{OH} determined using the iso-butene decay was observed, with larger uncertainties associated with this calibration compared to cyclohexane and *n*-pentane, and the reason for this remains unclear. On average, the measured OH signals were closer to the detection limit of the FAGE instrument when using iso-butene. Initial concentrations of each of the hydrocarbons were 2.5×10^{13} molecule cm⁻³, and hence a lower OH steady-state concentration is expected when iso-butene was present as the *k*_{OH} is an order of magnitude higher than those for *n*-pentane and cyclohexane. As *S*_{OH} approaches 0 counts s⁻¹ mW⁻¹, the *S*_{OH} measurement becomes increasingly imprecise, and thus the uncertainty in the fitting of the calibration plot increases.

A general under-prediction of C_{OH}, compared to the H₂O vapour photolysis method, was observed when calculated using the decay of cyclohexane, $C_{\text{OH}(\text{conv})}/C_{\text{OH}(\text{Chex})} = 1.52 \pm 0.44$. The exact reason is unknown. Evaluation of the HC decay data with the *k*_{OH} adjusted at the upper limit of uncertainty recommended by Calvert et al. (2008)

Title Page

Abstract

Introduction

Conclusions

References

Tables

Figures



Back

Close

Full Screen / Esc

Printer-friendly Version

Interactive Discussion



(25 % (2σ), $k_{\text{OH}} = 8.04 \times 10^{-12} \text{ cm}^3 \text{ molecule}^{-1} \text{ s}^{-1}$), brings the two datasets into better agreement, $C_{\text{OH}(\text{conv})}/C_{\text{OH}(\text{Chex})} = 1.21 \pm 0.22$. The cyclohexane measurements were also affected to a greater extent by the chamber dilution due to the slower rate of reaction with OH, which contributed to 25–30 % of the total cyclohexane decay rate directly after the photolysis lamps were initiated, compared to 5–10 % for the iso-butene experiments. Correcting the cyclohexane data for a hypothetically enhanced chamber dilution could explain the lower sensitivity measurements (as the decay increases, $[\text{OH}]_{\text{inf}}$ increases), however the dilution rate was confirmed prior to photolysis of TBHP in each experiment.

5.3 Formaldehyde photolysis calibration

Figure 10a shows the instrument sensitivity to HO_2 , C_{HO_2} , as a function of internal cell pressure for the newly developed formaldehyde photolysis calibration technique for the HIRAC FAGE instrument. Each data point corresponds to the average of up to five HO_2 decay traces (Fig. 8a) and the error bars are representative of the total calibration 1σ uncertainty (Sect. 5.4). All calibrations were completed over a 4–8 mW laser power range. The alternative calibration was observed to be in good agreement with the conventional H_2O vapour photolysis calibration technique over the operating internal cell pressure range between 1.8–3.8 mbar ($C_{\text{HO}_2(\text{conv})}/C_{\text{HO}_2(\text{alt})} = 0.96 \pm 0.09$) for the Litron based FAGE system.

The kinetics of the HO_2 decay due to recombination and first order wall loss (Eq. 6) were confirmed by studying the HO_2 decay profile with the chamber mixing fans on and off using the University of Leeds aircraft based FAGE instrument. With the mixing fans off, the decay was accurately described by the recombination kinetics only (Fig. 8b), giving C_{HO_2} values within error of the fans on experiments, as shown in Fig. 10b. Good agreement between the conventional and alternative calibration methods was also observed across the 1.42–2.48 mbar internal cell pressure range and the overall

Pressure dependent HO_x calibrations

F. A. F. Winiberg et al.

Title Page

Abstract

Introduction

Conclusions

References

Tables

Figures

◀

▶

◀

▶

Back

Close

Full Screen / Esc

Printer-friendly Version

Interactive Discussion



correlation between conventional and alternative calibration methods was calculated as $C_{\text{HO}_2(\text{conv})}/C_{\text{HO}_2(\text{alt})} = 1.07 \pm 0.09$ for the high frequency aircraft based FAGE instrument.

5.4 Calibration uncertainties

The overall uncertainty associated with the calibration methods presented here was calculated using the sum in quadrature of the accuracy and the precision terms of the calibration. The accuracy term accounted for any systematic uncertainty in the calculation of $[\text{HO}_x]$ for each calibration method, signal normalisation etc. and these are displayed in Table 2. The precision of the calibrations was defined as the random errors associated with each method. All uncertainties are quoted as 2σ .

5.4.1 H₂O photolysis calibration

The total uncertainty in the H₂O photolysis calibration method was estimated to be ~ 36%. The accuracy was defined by the uncertainty associated with each term of Eq. (1) in the determination of $[\text{HO}_x]$ and was estimated to be ~ 35%. The largest contribution to the accuracy of this calibration method came from the determination of the calibration source flux, $F_{184.9\text{nm}}$, with a total uncertainty of 32%. The product of the flux and the irradiation time from Eq. (1), $F_{184.9\text{nm}} \times \Delta t$, was determined using N₂O actinometry which relied on the detection of trace levels of NO (0.5–3 ppbv, Sect. 2.1) followed by evaluation of the measurements using four rate constants each with ~ 20% uncertainty. Although the actinometric method gives a direct determination of the product $F_{184.9\text{nm}} \times \Delta t$, in order to calculate $[\text{OH}]$ from Eq. (1) any difference between the total volumetric flow rate during the actinometry experiment and the OH calibration need to be accounted for as they change Δt . It is therefore necessary to account for the uncertainty in Δt , which was determined to be ~ 2% using the uncertainty in the flow rates from the mass flow controllers (~ 1%). For the remainder of the terms in Eq. (1) their contributions to the accuracy in the H₂O photolysis calibration method were as follows; $\sigma_{\text{H}_2\text{O}}$ was taken from Cantrell et al. (1997) with a reported total error of ±6%,

Title Page

Abstract

Introduction

Conclusions

References

Tables

Figures



Back

Close

Full Screen / Esc

Printer-friendly Version

Interactive Discussion



the error in $[\text{H}_2\text{O}]$ was taken from the hygrometer instrumental uncertainty ($\pm 10\%$), and laser power was defined by the laser power meter (Molelectron Powermax 500A, ± 0.25 mW).

The precision was typically between 4 and 10 % for the flow tube calibration process and was taken from the standard error in the error weighted fit of the calibration plot. The errors bars were representative of the standard deviation in the S_{OH} and $[\text{HO}_x]$ for the x- and y-axes respectively. The flux output of the calibration source, hygrometer and CPM measurements were observed to have good point-to-point stability and therefore low standard deviations.

5.4.2 Hydrocarbon decay calibration

The accuracy of the hydrocarbon decay method was estimated to be better than that of the flow tube method ($\sim 28\%$ compared to 35%). However, due to the large variation in the random errors that defined the precision of the experiment, the total uncertainty for the HC decay method was larger than the flow tube calibration method, with the total uncertainty estimated at $\sim 45\%$.

The accuracy in the calibration was intrinsic to the hydrocarbon used, being dependent on the uncertainty in k_{OH} and k_{Dil} . The largest uncertainty was in k_{OH} , taken from data reviews from the Calvert series or IUPAC recommendations: *n*-pentane, $\pm 20\%$ (Calvert et al., 2008), cyclohexane, $\pm 20\%$ (Calvert et al., 2008), iso-butene, $\pm 25\%$ (IUPAC, 2007). Uncertainty in k_{Dil} was calculated from repeated measurements of chamber dilution for each of the hydrocarbons, and induced errors in GC-FID calibration (4%). The precision of the experiments for both *n*-pentane and cyclohexane was between 10–25%, whereas iso-butene showed much greater variation of between 13–69%; possible reasons for which have been discussed in Sect. 5.2.

Pressure dependent HO_x calibrations

F. A. F. Winiberg et al.

Title Page

Abstract

Introduction

Conclusions

References

Tables

Figures



Back

Close

Full Screen / Esc

Printer-friendly Version

Interactive Discussion



5.4.3 Formaldehyde photolysis calibration

The total uncertainty for the HCHO photolysis calibration method has been estimated at ~ 46 %, which is 10 % greater than the conventional calibration method. The accuracy of the HCHO photolysis method was estimated as ~ 41 % with the largest contribution to this deriving from the uncertainty was in the HO₂ recombination rate constant (35 %), taken from the IUPAC recommendation (IUPAC, 2007). The uncertainty in the initial S_{HO₂} (i.e. S_{HO₂} at t₀) chosen for the analysis was based on the standard deviation of the offline signal, which gives an estimation of the 1 s point-to-point variability for a chosen t₀ (~ 20 %).

The error associated with the precision of the experiment was taken from the error propagation of the standard error terms from the Levenburg-Marquardt iterative fitting procedure for Eq. (7) and Fig. 8. This includes both the error in the C_{HO₂} and k_{loss} parameters. The precision for this method was in line with the conventional flow tube calibration between 10–20 %.

6 Conclusions and outlook

The first pressure dependent calibrations of a FAGE instrument for both OH and HO₂ have been successfully conducted using the HIRAC chamber. Previous pressure dependent aircraft measurements had been extracted by assuming that the calibration factor could be determined by simply calibrating at the required internal FAGE cell pressure. Assumptions were therefore made that variations in radical losses on the inlet and the nature of the expansion caused by the varying pressure differential inside and outside the FAGE cell were insignificant. The results displayed in Fig. 9 and Fig. 10 validate the conventional calibration method with the alternative hydrocarbon decay and HCHO photolysis methods over a range of internal FAGE cell pressures. As the calibration methods are quite different in principle, they are unlikely to be subject to the same systematic errors. The alternative calibration results presented here have

Title Page

Abstract

Introduction

Conclusions

References

Tables

Figures



Back

Close

Full Screen / Esc

Printer-friendly Version

Interactive Discussion



**Pressure dependent
HO_x calibrations**

F. A. F. Winiberg et al.

Title Page

Abstract

Introduction

Conclusions

References

Tables

Figures



Back

Close

Full Screen / Esc

Printer-friendly Version

Interactive Discussion



been shown to be well within the combined uncertainty of their respective traditional calibration method, validating the pressure dependent flow tube calibration technique and improving confidence in FAGE measurements both in the field and in kinetics experiments. Both alternative methods have also shown that calibrations conducted under high $[\text{H}_2\text{O}]_{\text{vap}}$ conditions (2000–4500 ppmv) can be applied to measurements at low $[\text{H}_2\text{O}]_{\text{vap}}$ (< 15 ppmv).

The hydrocarbon decay method has shown that the FAGE instrument can be calibrated over a range of external pressures using different hydrocarbons. Compared to the conventional calibration method, where $[\text{HO}_x]$ are generated typically at $> 10^8$ molecule cm^{-3} , the hydrocarbon decay method is conducted at a $[\text{HO}_x]$ relevant to chamber based experimental measurements ($\sim 10^7$ molecule cm^{-3}) and much closer to typical ambient OH concentrations ($\sim 10^6$ molecule cm^{-3}).

Currently the total error associated with the hydrocarbon decay method is greater than that of the flow tube method ($\sim 45\%$ vs. 36%). The accuracy or total systematic uncertainty associated with the alternative OH calibration method is lower than that of the flow tube calibration method (28% vs. 35%), and hence a improvement in the precision of the experiment could improve the overall uncertainty to be in line with the flow tube method. The primary source of random error arose in the detection of OH close to the detection limit. Increasing the steady state OH concentration in the chamber would allow easier detection of the hydrocarbon decay compared to chamber dilution, as well as an OH measurement above the detection limit. The steady state OH concentration could be increased by increasing the 254 nm intensity in the chamber, using new lamps or more lamps, altering the OH precursor, e.g. O_3 + alkenes or photolysis of methyl nitrite, or by lowering the initial $[\text{HC}]$. The latter would require a more sensitive hydrocarbon detection technique than GC-FID or FTIR which are currently available in HIRAC. One such technique is proton transfer mass spectrometry (PTR-MS) which would reduce the uncertainty in the hydrocarbon decay measurements by providing higher time resolution measurements and allow for easier simultaneous measurement of multiple hydrocarbons at low concentrations, effectively providing multiple

**Pressure dependent
HO_x calibrations**

F. A. F. Winiberg et al.

Title Page

Abstract

Introduction

Conclusions

References

Tables

Figures



Back

Close

Full Screen / Esc

Printer-friendly Version

Interactive Discussion



independent estimates of C_{OH} from a single experiment. Uncertainties in the rate coefficients could also be reduced, decreasing the systematic error, by a concerted laboratory study including relative rate and direct flash photolysis methods, with careful experimental design errors could be reduced to closer to 10 % (Orkin et al., 2010; Carr et al., 2011; Glowacki et al., 2012).

A full range of pressure dependent calibrations using this method would currently take ~ 2 days, compared to ~ 3 h for the flow tube based calibration. However, the time scale does not limit the suitability of the method for regular confirmation of C_{OH} obtained from the flow tube calibration method.

The total uncertainty in the HCHO photolysis method is ~ 46 % which is 10 % greater than that of the traditional H_2O photolysis method. The HCHO photolysis method is quick and reproducible. The time taken to complete the analysis and the errors are comparable with the flow tube technique. An advantage of the HCHO photolysis method is that several runs can be completed in one fill of the chamber, compared to the HC decay method that requires one fill per experiment (although the proposed use of multiple HC decays will provide multiple estimates of C_{OH} from a single chamber fill).

**The Supplement related to this article is available online at
doi:10.5194/amtd-7-7963-2014-supplement.**

Acknowledgements. This work was supported by funding from the Natural Environment Research Council (NERC grant NE/G523739/1), EUROCHAMP-2, and the National Centre for Atmospheric Science (NCAS). I. Bejan acknowledges Marie Curie fellowship. We are grateful for helpful discussions with Andrew Goddard and Mark Blitz on technical aspects of HIRAC and lasers, respectively.

References

Aschmutat, U., Hessling, M., Holland, F., and Hofzumahaus, A.: A tunable source of Hydroxyl (OH) and Hydroperoxy (HO₂) radicals: in the range between 10^6 and 10^9 cm^{-3} , in: Physico-

**Pressure dependent
HO_x calibrations**

F. A. F. Winiberg et al.

Title Page

Abstract

Introduction

Conclusions

References

Tables

Figures



Back

Close

Full Screen / Esc

Printer-friendly Version

Interactive Discussion



- Chemical Behaviour of Atmospheric Pollutants, edited by: Restelli, G. A. A. G., European Commission, Brussels, 811–816, 1994.
- Atkinson, R.: Kinetics and mechanisms of the gas-phase reactions of the hydroxyl radical with organic compounds under atmospheric conditions, *Chem. Rev.*, 86, 69–201, 1986.
- 5 Atkinson, R.: Kinetics of the gas-phase reactions of OH radicals with alkanes and cycloalkanes, *Atmos. Chem. Phys.*, 3, 2233–2307, doi:10.5194/acp-3-2233-2003, 2003.
- Atkinson, R. and Pitts, J. N. J.: Rate constants for the reaction of OH radicals with propylene and the butenes over the temperature range 297–425 K, *J. Chem. Phys.*, 63, 3591–3595, 1975.
- 10 Atkinson, R., Baulch, D. L., Cox, R. A., Crowley, J. N., Hampson, R. F., Hynes, R. G., Jenkin, M. E., Rossi, M. J., and Troe, J.: Evaluated kinetic and photochemical data for atmospheric chemistry: Volume I – gas phase reactions of O_x, HO_x, NO_x and SO_x species, *Atmos. Chem. Phys.*, 4, 1461–1738, doi:10.5194/acp-4-1461-2004, 2004.
- Baasandorj, M., Papanastasiou, D. K., Talukdar, R. K., Hasson, A. S., and Burkholder, J. B.: (CH₃)₃COOH (tert-butyl hydroperoxide): OH reaction rate coefficients between 206 and 15 375 K and the OH photolysis quantum yield at 248 nm, *Phys. Chem. Chem. Phys.*, 12, 12101–12111, doi:10.1039/c0cp00463d, 2010.
- Berresheim, H., Elste, T., Tremmel, H. G., Allen, A. G., Hansson, H. C., Rosman, K., Dal Maso, M., Makela, J. M., Kulmala, M., and O'Dowd, C. D.: Gas–aerosol relationships of H₂SO₄, MSA, and OH: observations in the coastal marine boundary layer at Mace Head, Ireland, *J. Geophys. Res.-Atmos.*, 107, 8100, doi:10.1029/2000JD000229, 2002.
- 20 Bloss, W. J., Lee, J. D., Bloss, C., Heard, D. E., Pilling, M. J., Wirtz, K., Martin-Reviejo, M., and Siese, M.: Validation of the calibration of a laser-induced fluorescence instrument for the measurement of OH radicals in the atmosphere, *Atmos. Chem. Phys.*, 4, 571–583, doi:10.5194/acp-4-571-2004, 2004.
- 25 Brauers, T., Aschmutat, U., Brandenburger, U., Dorn, H. P., Hausmann, M., Hessling, M., Hofzumahaus, A., Holland, F., PlassDulmer, C., and Ehhalt, D. H.: Intercomparison of tropospheric OH radical measurements by multiple folded long-path laser absorption and laser induced fluorescence, *Geophys. Res. Lett.*, 23, 2545–2548, 1996.
- 30 Calvert, J. G., Atkinson, R., Kerr, J. A., Madronich, S., Moortgat, G. K., Wallington, T. J., and Yarwood, G.: *The Mechanism of Atmospheric Oxidation of the Alkenes*, OUP, Oxford, 2000.
- Calvert, J. G., Derwent, R. G., Orlando, J. J., Tyndall, G. S., and Wallington, T. J.: *Mechanisms of Atmospheric Oxidation of the Alkanes*, Oxford University Press, 2008.

**Pressure dependent
HO_x calibrations**

F. A. F. Winiberg et al.

Title Page

Abstract

Introduction

Conclusions

References

Tables

Figures



Back

Close

Full Screen / Esc

Printer-friendly Version

Interactive Discussion



- Campuzano-Jost, P., Williams, M. B., D'Ottone, L., and Hynes, A. J.: Kinetics and mechanism of the reaction of the hydroxyl radical with h(8)-isoprene and d(8)-isoprene: isoprene absorption cross sections, rate coefficients, and the mechanism of hydroperoxyl radical production, *J. Phys. Chem. A*, 108, 1537–1551, doi:10.1021/jp0363601, 2004.
- 5 Cantrell, C. A., Tyndall, G., and Zimmer, A.: Absorption cross sections for water vapour from 183 to 193 nm, *Geophys. Res. Lett.*, 24, 2195–2198, 1997.
- Carr, S. A., Blitz, M. A., and Seakins, P. W.: Site-specific rate coefficients for reaction of OH with ethanol from 298 to 900 K, *J. Phys. Chem. A*, 115, 3335–3345, doi:10.1021/jp200186t, 2011.
- 10 Commane, R., Floquet, C. F. A., Ingham, T., Stone, D., Evans, M. J., and Heard, D. E.: Observations of OH and HO₂ radicals over West Africa, *Atmos. Chem. Phys.*, 10, 8783–8801, doi:10.5194/acp-10-8783-2010, 2010.
checkCopernicus Publication!
- Creasey, D. J., Halford-Maw, P. A., Heard, D. E., Pilling, M. J., and Whitaker, B. J.: Implementation and initial deployment of a field instrument for measurement of OH and HO₂ in the troposphere by laser-induced fluorescence, *J. Chem. Soc. Faraday T.*, 93, 2907–2913, 1997a.
- 15 Creasey, D. J., Heard, D. E., Pilling, M. J., Whitaker, B. J., Berzins, M., and Fairlie, R.: Visualisation of a supersonic free-jet expansion using laser-induced fluorescence spectroscopy: application to the measurement of rate constants at ultralow temperatures, *Appl. Phys. B*, 65, 375–391, 1997b.
- 20 Creasey, D. J., Heard, D. E., and Lee, J. D.: Absorption cross-section measurements of water vapour and oxygen at 185 nm. Implications for the calibration of field instruments to measure OH, HO₂ and RO₂ radicals, *Geophys. Res. Lett.*, 27, 1651–1654, doi:10.1029/1999gl011014, 2000.
- 25 Davis, D. D., Heaps, W., and McGee, T.: Direct measurements of natural tropospheric levels of OH via an aircraft borne tunable dye-laser, *Geophys. Res. Lett.*, 3, 331–333, 1976.
- Dorn, H. P., Brandenburger, U., Brauers, T., Hausmann, M., and Ehhalt, D. H.: In-situ detection of tropospheric OH radicals by folded long-path laser absorption. Results from the POPCORN field campaign in August 1994, *Geophys. Res. Lett.*, 23, 2537–2540, doi:10.1029/96gl02206, 1996.
- 30

**Pressure dependent
HO_x calibrations**

F. A. F. Winiberg et al.

Title Page

Abstract

Introduction

Conclusions

References

Tables

Figures



Back

Close

Full Screen / Esc

Printer-friendly Version

Interactive Discussion



Dusanter, S., Vimal, D., and Stevens, P. S.: Technical note: Measuring tropospheric OH and HO₂ by laser-induced fluorescence at low pressure. A comparison of calibration techniques, *Atmos. Chem. Phys.*, 8, 321–340, doi:10.5194/acp-8-321-2008, 2008.

Edwards, G. D., Cantrell, C., Stephens, S., Hill, B., Goyea, O., Shetter, R., Mauldin, R. L., Kosciuch, E., Tanner, D., and Eisele, F.: Chemical ionization mass spectrometer instrument for the measurement of tropospheric HO₂ and RO₂, *Anal. Chem.*, 75, 5317–5327, 2003.

Eisele, F., Mauldin, L., Cantrell, C., Zondlo, M., Apel, E., Fried, A., Walega, J., Shetter, R., Lefer, B., Flocke, F., Weinheimer, A., Avery, M., Vay, S., G., S., Podolske, J., Diskin, G., Barrick, J. D., Singh, H. B., Brune, W., Harder, H., Martinez, M., Bandy, A., Thornton, D., Heikes, B., Kondo, Y., Riemer, D., Sandholm, S., Tan, D., Talbot, R., and Dibb, J.: Summary of measurement intercomparisons during TRACE-P, *J. Geophys. Res.*, 108, 8791–8810, 2003.

Eisele, F. L. and Tanner, D. J.: Ion-Assisted Tropospheric OH Measurements, *J. Geophys. Res.-Atmos*, 96, 9295–9308, 1991.

Eisele, F. L., Mauldin, R. L., Tanner, D. J., Cantrell, C., Kosciuch, E., Nowak, J. B., Brune, B., Faloon, I., Tan, D., Davis, D. D., Wang, L., and Chen, G.: Relationship between OH measurements on two different NASA aircraft during PEM Tropics B, *J. Geophys. Res.-Atmos.*, 106, 32683–32689, 2001.

Evaluated Kinetic Data: IUPAC: Task Group on Atmospheric Chemical Kinetic Data, available at: iupac.pole-ether.fr/index.html (last access: 1 May 2014), 2007.

Faloon, I., Tan, D., Brune, W. H., Jaegle, L., Jacob, D. J., Kondo, Y., Koike, M., Chatfield, R., Poeschel, R., Ferry, G., Sachse, G., Vay, S., Anderson, B., Hannon, J., and Fuelberg, H.: Observations of HO_x and its relationship with NO_x in the upper troposphere during SONEX, *J. Geophys. Res.-Atmos.*, 105, 3771–3783, 2000.

Faloon, I. C., Tan, D., Leshner, R. L., Hazen, N. L., Frame, C. L., Simpas, J. B., Harder, H., Martinez, M., Di Carlo, P., Ren, X. R., and Brune, W. H.: A laser-induced fluorescence instrument for detecting tropospheric OH and HO₂: characteristics and calibration, *J. Atmos. Chem.*, 47, 139–167, doi:10.1023/B:JOCH.0000021036.53185.0e, 2004.

Fuchs, H., Bohn, B., Hofzumahaus, A., Holland, F., Lu, K. D., Nehr, S., Rohrer, F., and Wahner, A.: Detection of HO₂ by laser-induced fluorescence: calibration and interferences from RO₂ radicals, *Atmos. Meas. Tech.*, 4, 1209–1225, doi:10.5194/amt-4-1209-2011, 2011.

Fuchs, H., Dorn, H.-P., Bachner, M., Bohn, B., Brauers, T., Gomm, S., Hofzumahaus, A., Holland, F., Nehr, S., Rohrer, F., Tillmann, R., and Wahner, A.: Comparison of OH concentration measurements by DOAS and LIF during SAPHIR chamber experiments at high OH reactiv-

ity and low NO concentration, *Atmos. Meas. Tech.*, 5, 1611–1626, doi:10.5194/amt-5-1611-2012, 2012.

Glowacki, D. R., Goddard, A., Hemavibool, K., Malkin, T. L., Commane, R., Anderson, F., Bloss, W. J., Heard, D. E., Ingham, T., Pilling, M. J., and Seakins, P. W.: Design of and initial results from a Highly Instrumented Reactor for Atmospheric Chemistry (HIRAC), *Atmos. Chem. Phys.*, 7, 5371–5390, doi:10.5194/acp-7-5371-2007, 2007a.

Glowacki, D. R., Goddard, A., and Seakins, P. W.: Design and performance of a throughput-matched, zero-geometric-loss, modified three objective multipass matrix system for FTIR spectrometry, *Appl. Optics*, 46, 7872–7883, doi:10.1364/ao.46.007872, 2007b.

Glowacki, D. R., Lockhart, J., Blitz, M. A., Klippenstein, S. J., Pilling, M. J., Robertson, S. H., and Seakins, P. W.: Interception of excited vibrational quantum states by O₂ in atmospheric association reactions, *Science*, 337, 1066–1067, doi:10.1126/science.1224106, 2012.

Guggenheim, E. A.: On the determination of the velocity constant of a unimolecular reaction, *Philos. Mag.*, 2, 538–543, 1926.

Hard, T. M., George, L. A., and O'Brien, R. J.: FAGE determination of tropospheric HO and HO₂, *J. Atmos. Sci.*, 52, 3354–3372, 1995.

Heard, D. E.: Atmospheric field measurements of the hydroxylradical using laser-induced fluorescence spectroscopy, *Annu. Rev. Phys. Chem.*, 57, 191–216, doi:10.1146/annurev.physchem.57.032905.104516, 2006.

Heard, D. E. and Pilling, M. J.: Measurement of OH and HO₂ in the troposphere, *Chem. Rev.*, 103, 5163–5198, 2003.

Hofzumahaus, A., Brauers, T., Aschmutat, U., Brandenburger, U., Dorn, H. P., Hausmann, M., Heßling, M., Holland, F., Plass-Dulmer, C., Sedlacek, M., Weber, M., and Ehhalt, D. H.: The measurement of tropospheric OH radicals by laser-induced fluorescence spectroscopy during the POPCORN field campaign and Intercomparison of tropospheric OH radical measurements by multiple folded long-path laser absorption and laser induced fluorescence – reply, *Geophys. Res. Lett.*, 24, 3039–3040, 1997.

Holland, F., Hessling, M., and Hofzumahaus, A.: In-situ measurement of tropospheric OH radicals by laser-induced fluorescence – a description of the KFA instrument, *J. Atmos. Sci.*, 52, 3393–3401, 1995.

Kukui, A., Ancellet, G., and Le Bras, G.: Chemical ionisation mass spectrometer for measurements of OH and Peroxy radical concentrations in moderately polluted atmospheres, *J. Atmos. Chem.*, 61, 133–154, doi:10.1007/s10874-009-9130-9, 2008.

Pressure dependent HO_x calibrations

F. A. F. Winiberg et al.

Title Page

Abstract

Introduction

Conclusions

References

Tables

Figures



Back

Close

Full Screen / Esc

Printer-friendly Version

Interactive Discussion



**Pressure dependent
HO_x calibrations**

F. A. F. Winiberg et al.

Title Page

Abstract

Introduction

Conclusions

References

Tables

Figures



Back

Close

Full Screen / Esc

Printer-friendly Version

Interactive Discussion



- Malkin, T. L.: Detection of Free-Radicals and Other Species to Investigate Atmospheric Chemistry in the HIRAC Chamber, University of Leeds (School of Chemistry), Leeds, xvii, 285, 215 pp., 2010.
- Malkin, T. L., Goddard, A., Heard, D. E., and Seakins, P. W.: Measurements of OH and HO₂ yields from the gas phase ozonolysis of isoprene, *Atmos. Chem. Phys.*, 10, 1441–1459, doi:10.5194/acp-10-1441-2010, 2010.
- Mao, J., Ren, X., Zhang, L., Van Duin, D. M., Cohen, R. C., Park, J.-H., Goldstein, A. H., Paulot, F., Beaver, M. R., Crounse, J. D., Wennberg, P. O., DiGangi, J. P., Henry, S. B., Keutsch, F. N., Park, C., Schade, G. W., Wolfe, G. M., Thornton, J. A., and Brune, W. H.: Insights into hydroxyl measurements and atmospheric oxidation in a California forest, *Atmos. Chem. Phys.*, 12, 8009–8020, doi:10.5194/acp-12-8009-2012, 2012.
- Martinez, M., Harder, H., Kubistin, D., Rudolf, M., Bozem, H., Eerdeken, G., Fischer, H., Klüpfel, T., Gurk, C., Königstedt, R., Parchatka, U., Schiller, C. L., Stickler, A., Williams, J., and Lelieveld, J.: Hydroxyl radicals in the tropical troposphere over the Suriname rainforest: airborne measurements, *Atmos. Chem. Phys.*, 10, 3759–3773, doi:10.5194/acp-10-3759-2010, 2010.
- Novelli, A., Hens, K., Tatum Ernest, C., Kubistin, D., Regelin, E., Elste, T., Plass-Dülmer, C., Martinez, M., Lelieveld, J., and Harder, H.: Characterisation of an inlet pre-injector laser induced fluorescence instrument for the measurement of ambient hydroxyl radicals, *Atmos. Meas. Tech. Discuss.*, 7, 819–858, doi:10.5194/amtd-7-819-2014, 2014.
- Orkin, V. L., Martynova, L. E., and Ilichev, A. N.: High-Accuracy Measurements of OH Reaction Rate Constants and IR Absorption Spectra: CH₂=CF-CF₃ and *trans*-CHF=CH-CF₃, *J. Phys. Chem. A*, 114, 5967–5979, doi:10.1021/jp9092817, 2010.
- Park, J., Jongsma, C. G., Zhang, R. Y., and North, S. W.: OH/OD initiated oxidation of isoprene in the presence of O₂ and NO, *J. Phys. Chem. A*, 108, 10688–10697, doi:10.1021/jp040421t, 2004.
- Pilling, M. J. and Seakins, P. W.: *Reaction Kinetics*, Oxford University Press, Oxford, 1995.
- Pilling, M. J., Bloss, W. J., and Wirtz, K.: IALSI: Processes Relevant to Global Change – Improvements and Access to a Large Simulation Chamber, Fundacion CEAM, Valencia, Spain, 2005.
- Regelin, E., Harder, H., Martinez, M., Kubistin, D., Tatum Ernest, C., Bozem, H., Klippel, T., Hosaynali-Beygi, Z., Fischer, H., Sander, R., Jöckel, P., Königstedt, R., and Lelieveld, J.: HO_x measurements in the summertime upper troposphere over Europe: a comparison of

**Pressure dependent
HO_x calibrations**

F. A. F. Winiberg et al.

Title Page

Abstract

Introduction

Conclusions

References

Tables

Figures



Back

Close

Full Screen / Esc

Printer-friendly Version

Interactive Discussion



observations to a box model and a 3-D model, *Atmos. Chem. Phys.*, 13, 10703–10720, doi:10.5194/acp-13-10703-2013, 2013.

Schlosser, E., Brauers, T., Dorn, H.-P., Fuchs, H., Hofzumahaus, A., Holland, F., and A. Wahner: Intercomparison of two hydroxyl radical measurement techniques at the atmosphere simulation chamber SAPHIR, *J. Atmos. Chem.*, 56, 187–205, 2007.

Schlosser, E., Brauers, T., Dorn, H.-P., Fuchs, H., Häseler, R., Hofzumahaus, A., Holland, F., Wahner, A., Kanaya, Y., Kajii, Y., Miyamoto, K., Nishida, S., Watanabe, K., Yoshino, A., Kubistin, D., Martinez, M., Rudolf, M., Harder, H., Berresheim, H., Elste, T., Plass-Dülmer, C., Stange, G., and Schurath, U.: Technical Note: Formal blind intercomparison of OH measurements: results from the international campaign HO_xComp, *Atmos. Chem. Phys.*, 9, 7923–7948, doi:10.5194/acp-9-7923-2009, 2009.

Schultz, M., Heitlinger, M., Mihelcic, D., and Volzthomas, A.: Calibration source for peroxy radicals with built-in actinometry using H₂O and O₂ photolysis at 185 nm, *J. Geophys. Res.-Atmos.*, 100, 18811–18816, doi:10.1029/95jd01642, 1995.

Singh, S. and Li, Z. J.: Kinetics investigation of OH reaction with isoprene at 240–340 K and 1–3 Torr using the relative rate/discharge flow/mass spectrometry technique, *J. Phys. Chem. A*, 111, 11843–11851, doi:10.1021/jp074148h, 2007.

Sjostedt, S. J., Huey, L. G., Tanner, D. J., Peischl, J., Chen, G., Dibb, J. E., Lefer, B., Hutterli, M. A., Beyersdorf, A. J., Blake, N. J., Blake, D. R., Sueper, D., Ryerson, T., Burkhardt, J., and Stohl, A.: Observations of hydroxyl and the sum of peroxy radicals at Summit, Greenland during summer 2003, *Atmos. Environ.*, 41, 5122–5137, 2007.

Stevens, P. S., Mather, J. H., and Brune, W. H.: Measurement of tropospheric OH and HO₂ by laser-induced fluorescence at low-pressure, *J. Geophys. Res.-Atmos.*, 99, 3543–3557, 1994.

Stone, D. and Rowley, D. M.: Kinetics of the gas phase HO₂ self-reaction: effects of temperature, pressure, water and methanol vapours, *Phys. Chem. Chem. Phys.*, 7, 2156–2163, 2005.

Wennberg, P. O., Cohen, R. C., Hazen, N. L., Lapson, L. B., Allen, N. T., Hanisco, T. F., Oliver, J. F., Lanham, N. W., Demusz, J. N., and Anderson, J. G.: Aircraft-borne, laser-induced fluorescence instrument for the in-situ detection of hydroxyl and hydroperoxyl radicals, *Rev. Sci. Instrum.*, 65, 1858–1876, 1994.

Whalley, L. K., Furneaux, K. L., Gravestock, T. J., Atkinson, H. M., Bale, C. S. E., Ingham, T., Bloss, W. J., and Heard, D. E.: Detection of iodine monoxide radicals in the marine boundary layer using laser induced fluorescence spectroscopy, *J. Atmos. Chem.*, 58, 19–39, 2007.

Whalley, L. K., Furneaux, K. L., Goddard, A., Lee, J. D., Mahajan, A., Oetjen, H., Read, K. A., Kaaden, N., Carpenter, L. J., Lewis, A. C., Plane, J. M. C., Saltzman, E. S., Wiedensohler, A., and Heard, D. E.: The chemistry of OH and HO₂ radicals in the boundary layer over the tropical Atlantic Ocean, *Atmos. Chem. Phys.*, 10, 1555–1576, doi:10.5194/acp-10-1555-2010, 2010.

Whalley, L. K., Blitz, M. A., Desservettaz, M., Seakins, P. W., and Heard, D. E.: Reporting the sensitivity of laser-induced fluorescence instruments used for HO₂ detection to an interference from RO₂ radicals and introducing a novel approach that enables HO₂ and certain RO₂ types to be selectively measured, *Atmos. Meas. Tech.*, 6, 3425–3440, doi:10.5194/amt-6-3425-2013, 2013.

Winiberg, F. A. F.: Characterisation of FAGE apparatus for HO_x detection and application in an environmental chamber, Ph.D. thesis, School of Chemistry, University of Leeds, Leeds, 233 pp., 2014.

AMTD

7, 7963–8011, 2014

Pressure dependent HO_x calibrations

F. A. F. Winiberg et al.

Title Page

Abstract

Introduction

Conclusions

References

Tables

Figures



Back

Close

Full Screen / Esc

Printer-friendly Version

Interactive Discussion



Pressure dependent HO_x calibrations

F. A. F. Winiberg et al.

Title Page

Abstract

Introduction

Conclusions

References

Tables

Figures



Back

Close

Full Screen / Esc

Printer-friendly Version

Interactive Discussion



Table 1. FAGE instruments used and their respective laser systems and calibration methods used.

FAGE Instrument	Laser	Calibrations conducted
Aircraft	Photonics Industries (5 kHz PRF) Nd:YAG (DS-532-10) pumped Ti:Sa (TU-UV-308)	H ₂ O vapour photolysis, HCHO photolysis
HIRAC	LITRON, NANO-TRL-250, (200 Hz PRF) Nd:YAG pumped dye laser (Lambda Physik, LPD3000)	H ₂ O vapour photolysis, HCHO photolysis, HC decay

Pressure dependent HO_x calibrations

F. A. F. Winiberg et al.

Table 2. The systematic uncertainties in the various parameters that determine the accuracy in the OH and HO₂ calibration factors for all three calibration methods. Total accuracy is taken as the sum in quadrature of the individual uncertainties. The online position error is the approximate error in the maximum line intensity that is achieved when positioning the laser wavelength at the centre of the OH transition.

H ₂ O + <i>hν</i>		Hydrocarbon Decay		HCHO + <i>hν</i>	
Parameter	Uncertainty	Parameter	Uncertainty	Parameter	Uncertainty
<i>F</i> _{184.9nm}	32 %	<i>k</i> _{OH}	20–25 %	<i>k</i> _{HO₂+HO₂}	35 %
Δt	2 %	<i>k</i> _{Dil}	10 %	<i>S</i> _{HO₂} initial	20 %
[H ₂ O]	10 %	GC-FID	4 %	Laser power	6 %
σ _{H₂O,184.9nm}	6 %	Laser power	6 %	Online Position	4 %
Laser power	6 %	Online Position	4 %		
Online Position	4 %				
Error	35 %	Error	24–28 %	Error	41 %

Title Page

Abstract

Introduction

Conclusions

References

Tables

Figures

◀

▶

◀

▶

Back

Close

Full Screen / Esc

Printer-friendly Version

Interactive Discussion



Pressure dependent
HO_x calibrations

F. A. F. Winiberg et al.

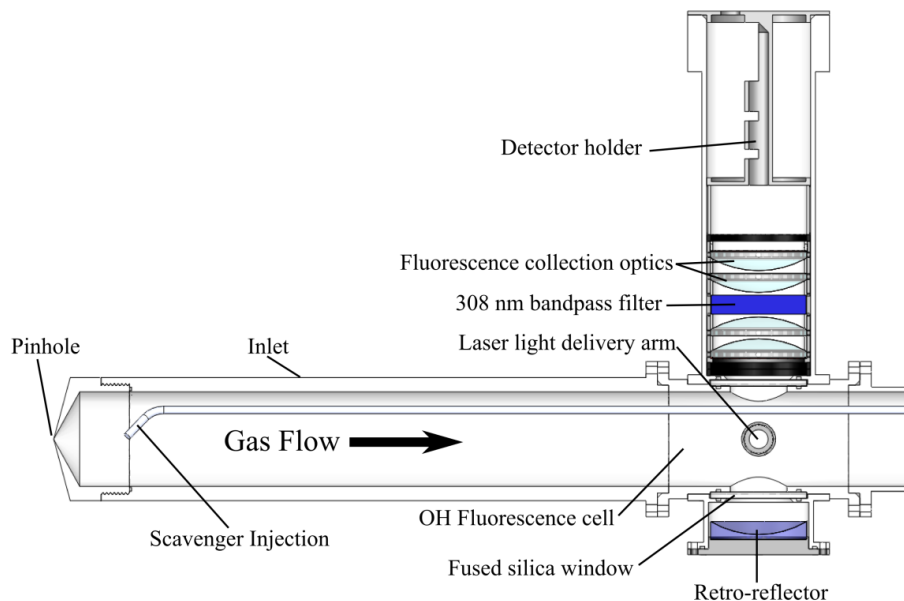

Figure 1. Schematic showing a side-on vertical cross section of the HIRAC FAGE OH fluorescence cell. The OH scavenger (iso-butane) was introduced ~ 40 mm from the inlet pinhole through an $1/8''$ internal diameter stainless steel tube mounted in between the OH and HO₂ cells (out of frame). The tube ran flush to the cell wall to reduce possible scattering of laser light and the tip was angled slightly towards the centre the main gas flow to improve mixing.

[Title Page](#)[Abstract](#)[Introduction](#)[Conclusions](#)[References](#)[Tables](#)[Figures](#)[◀](#)[▶](#)[◀](#)[▶](#)[Back](#)[Close](#)[Full Screen / Esc](#)[Printer-friendly Version](#)[Interactive Discussion](#)

Pressure dependent HO_x calibrations

F. A. F. Winiberg et al.

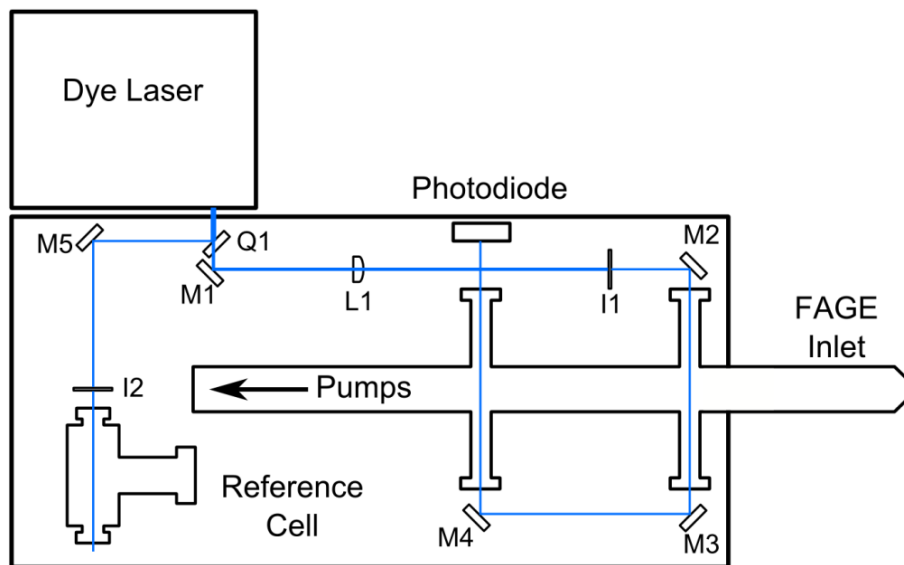

Figure 2. Top-down schematic of the FAGE instrument showing the laser beam path (blue line) through the OH and HO₂ detection cells, and the reference cell using the LITRON/LPD3000, 200 Hz PRF laser source. *Q* = quartz flat, *M* = mirror, *I* = iris and *L* = lens. The FAGE inlet is extended past the edge of the mounting table for insertion into the HIRAC chamber. The calibrated photodiode was used to normalise the fluorescence signals to fluctuations in laser power.

Title Page

Abstract

Introduction

Conclusions

References

Tables

Figures

◀

▶

◀

▶

Back

Close

Full Screen / Esc

Printer-friendly Version

Interactive Discussion



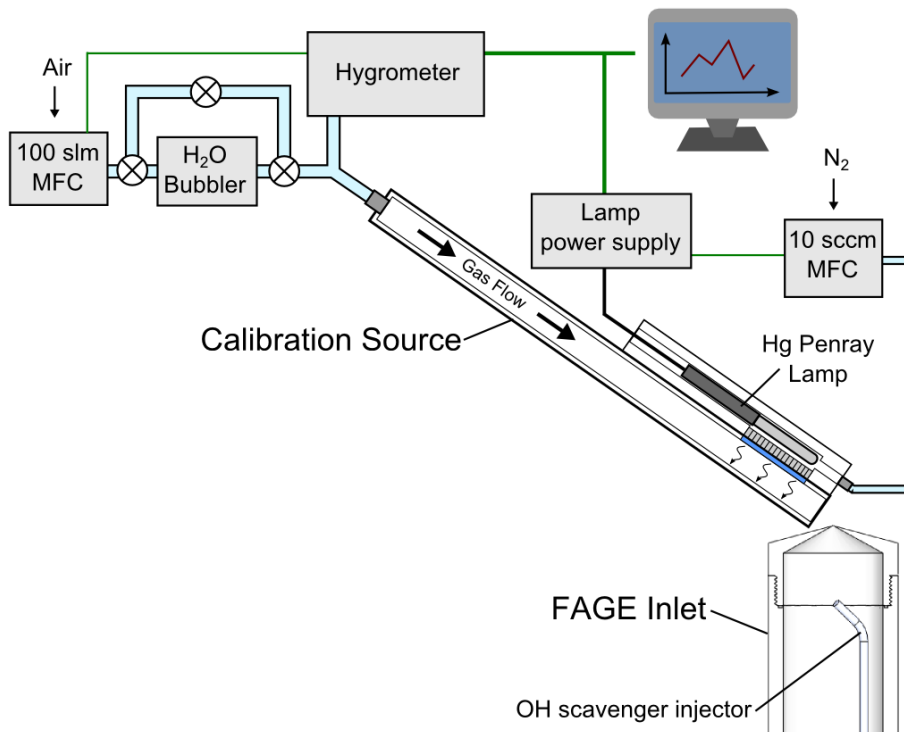

Figure 3. Schematic cross section of the H₂O vapour photolysis calibration source used in the calibration of the FAGE instrument. The $[H_2O]_{\text{vapour}}$ was measured prior to entering the square cross section flow tube, and the concentration was controlled through a series of three taps around the bubbler. The Hg penray lamp was housed in a second section of the wand and the output was collimated through a Suprasil window using a honeycomb arrangement of $\phi = 1$ mm aluminium tubes. The lamp was continuously flushed with N₂ to remove potential absorbers and photolabile species, and to help regulate temperature.

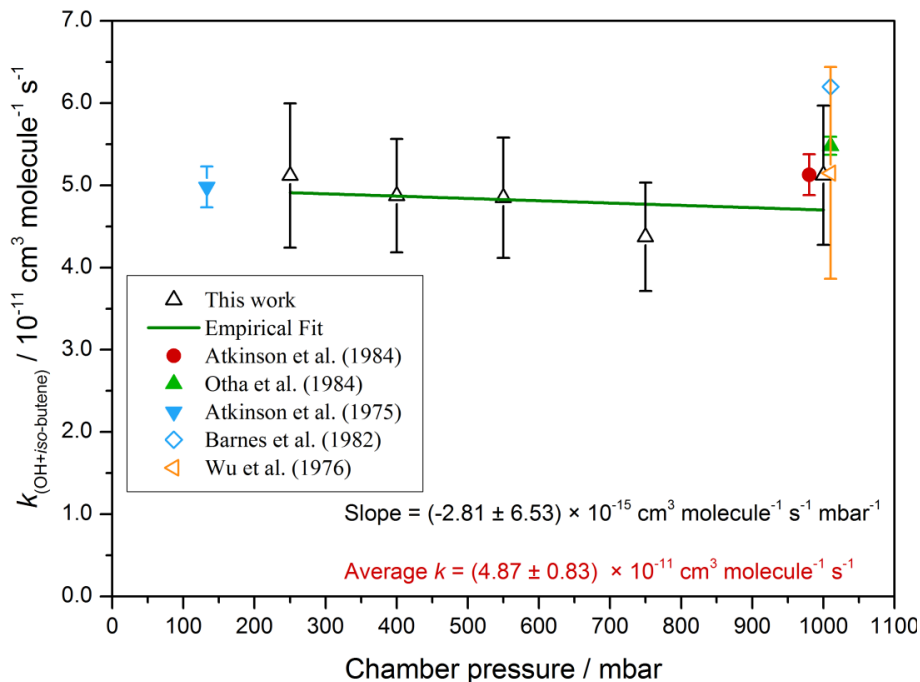

Figure 4. Rate constant, k_{OH} , for iso-butene + OH over the 250–1000 mbar pressure range measured relative to an isoprene reference in the HIRAC chamber. An empirical linear least-squares fit to the data is shown to emphasise lack of observed pressure dependence in the measured rate constant. Error bars represent the standard error ($\pm 1\sigma$) in the associated relative rate determination of k_{OH} and linear regression is weighted to account for this.

**Pressure dependent
HO_x calibrations**

F. A. F. Winiberg et al.

Title Page

Abstract

Introduction

Conclusions

References

Tables

Figures



Back

Close

Full Screen / Esc

Printer-friendly Version

Interactive Discussion



Pressure dependent HO_x calibrations

F. A. F. Winiberg et al.

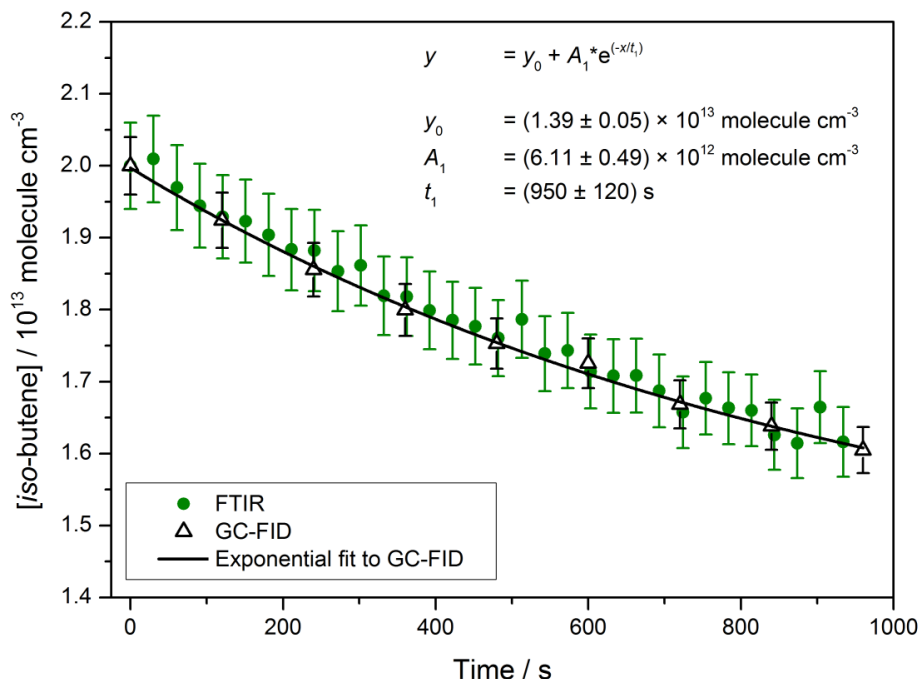

Figure 5. Decay of iso-butene as a function of time through reaction with OH in HIRAC (750 mbar, 294 K), measured using GC-FID on a 2 min time resolution. The data are fitted with a first order exponential decay (purely empirical) to allow calculation of [HC] on the same time scale as the 60 s averaged FAGE data. Time = 0 s indicates photolysis lamp turn-on time and uncertainties are quoted to $\pm 1\sigma$. Error bars are representative of the precision in the GC-FID ($\sim 2\%$) and FTIR ($\sim 3\%$) measurements to 1σ .

Title Page

Abstract

Introduction

Conclusions

References

Tables

Figures

◀

▶

◀

▶

Back

Close

Full Screen / Esc

Printer-friendly Version

Interactive Discussion



Pressure dependent
HO_x calibrations

F. A. F. Winiberg et al.

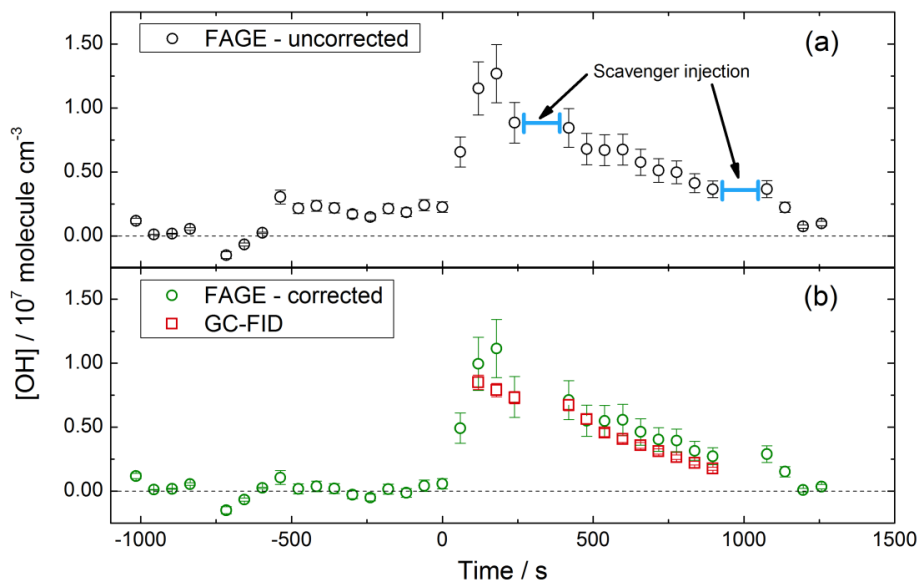

Figure 6. Comparison of [OH] traces measured using FAGE during the photooxidation of *n*-pentane at 1000 mbar and 293 K before, **(a)** and after, **(b)**, correcting for laser generated OH due to TBHP photolysis in the OH fluorescence cell. The 200 Hz PRF laser system was used for these measurements. The uncorrected and corrected FAGE signal was converted to [OH] using $C_{\text{OH}} = 3.6 \times 10^{-8} \text{ counts cm}^3 \text{ s}^{-1} \text{ molecule}^{-1} \text{ mW}^{-1}$ determined using the conventional calibration method for comparison with GC-FID data. The TBHP ($3.2 \times 10^{13} \text{ molecule cm}^{-3}$) and *n*-pentane ($2.1 \times 10^{13} \text{ molecule cm}^{-3}$) were introduced into the chamber at $t \approx -500 \text{ s}$ and the photolysis lamps were switched on at $t = 0 \text{ s}$. The [OH] inferred from the HC decay method is also displayed in **(b)**. Dashed line at $y = 0$ given for clarity.



Pressure dependent
HO_x calibrations

F. A. F. Winiberg et al.

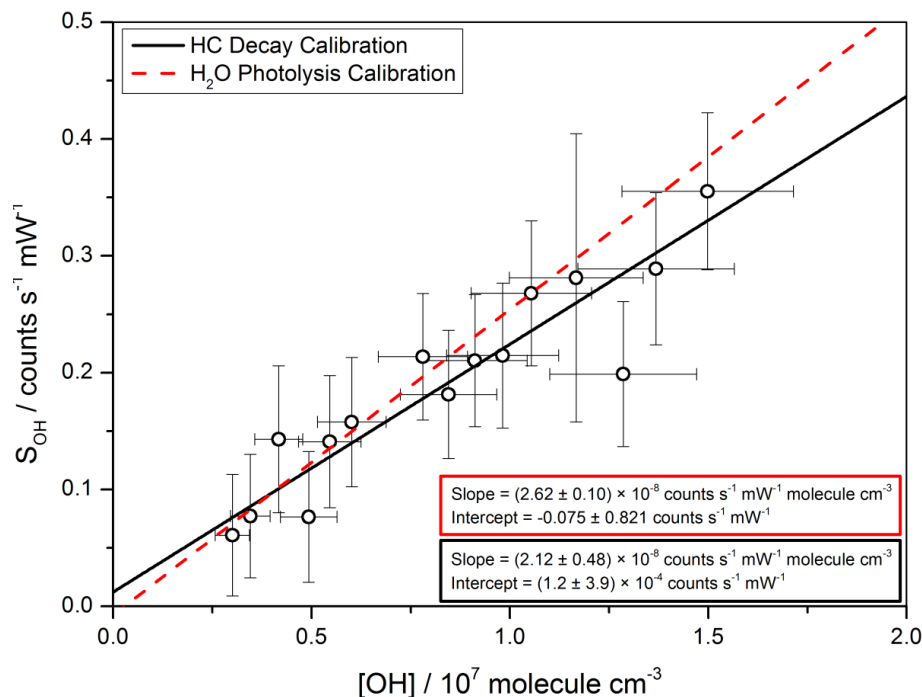

Figure 7. Calibration from the hydrocarbon decay method for iso-butene at 1000 mbar and 293 K chamber pressure using the 200 Hz PRF laser system; inlet pressure = (3.81 ± 0.02) mbar; laser power = (7.0 ± 0.5) mW. Extrapolated calibration from the H₂O photolysis calibration technique for inlet pressure = (3.79 ± 0.02) mbar, laser power = (6.0 ± 0.5) mW, $[\text{H}_2\text{O}]_{\text{vapour}} = (3900 \pm 20)$ ppmv and $[\text{OH}] = (0.5\text{--}1.5) \times 10^9 \text{ molecule cm}^{-3}$. Both fits are weighted to errors in the x and y axes. Uncertainties quoted represent the precision of the calibration processes to $\pm 2\sigma$.

Pressure dependent
HO_x calibrations

F. A. F. Winiberg et al.

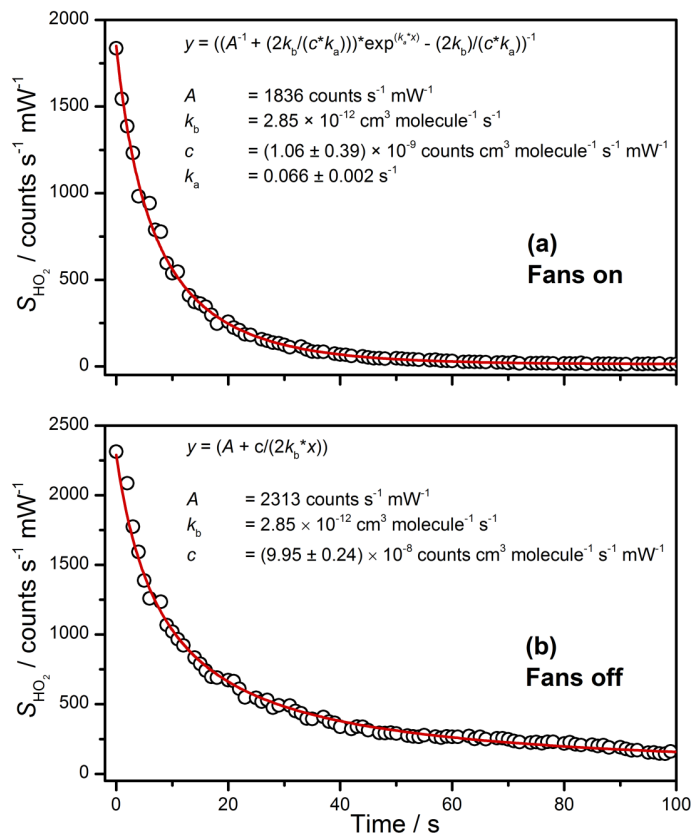

Figure 8. Normalised S_{HO_2} decay for the HCHO photolysis calibration method at 1000 mbar chamber pressure using the aircraft FAGE instrument with the 5 Hz PRF laser system conducted with the HIRAC chamber mixing fans on **(a)** and off **(b)**; inlet pressure = (2.53 ± 0.02) mbar; laser power = (8.25 ± 0.25) mW. Data in **(a)** were fitted with Eq. (9) to give C_{HO_2} where $A = (S_{\text{HO}_2})_0$, $k_b = k_{\text{HO}_2+\text{HO}_2}$, $c = C_{\text{HO}_2}$, $k_a = k_{\text{loss}}$ and $z = \text{offset}$, with uncertainties quoted to $\pm 1\sigma$. Parameters without quoted error were fixed.

Title Page

Abstract

Introduction

Conclusions

References

Tables

Figures

◀

▶

◀

▶

Back

Close

Full Screen / Esc

Printer-friendly Version

Interactive Discussion



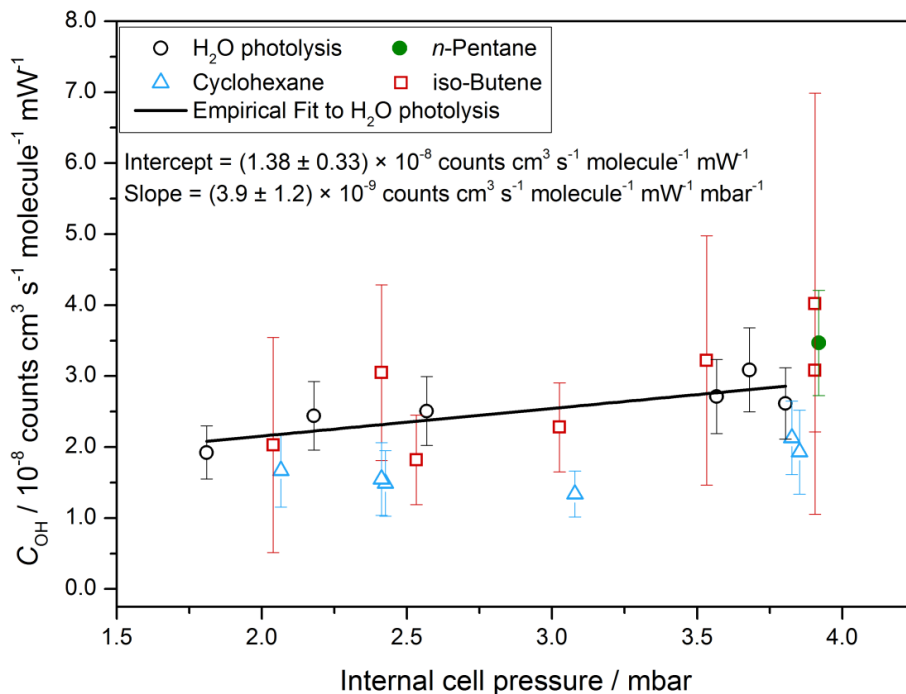

Figure 9. FAGE instrument sensitivity to OH, C_{OH} , as a function of internal detection cell pressure as determined by the H₂O vapour photolysis and HC decay calibration techniques using the LITRON Nd:YAG pumped dye laser operating at 200 Hz PRF. All calibrations were conducted at laser powers between 6.0–9.5 mW. Conventional calibrations were conducted at constant $[\text{H}_2\text{O}]_{\text{vap}}$ (4500 ± 600 ppmv) whereas alternative calibrations were conducted in near dry conditions (< 15 ppmv). HIRAC chamber pressures between 440–1000 mbar were used to induce internal cell pressures between 2.1–3.9 mbar. Error bars indicate the total uncertainty to $\pm 1\sigma$.

Pressure dependent HO_x calibrations

F. A. F. Winiberg et al.

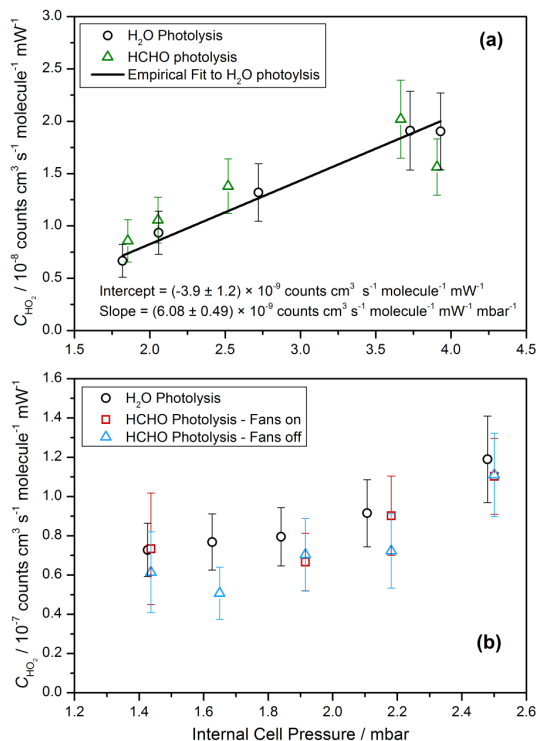

Figure 10. FAGE instrument sensitivity to HO₂, C_{HO_2} , as a function of internal detection cell pressure as determined by the H₂O vapour and HCHO photolysis calibration techniques using the HIRAC FAGE instrument operating at 200 Hz PRF **(a)** and the aircraft FAGE instrument operating at 5 kHz PRF **(b)**. Conventional calibrations were conducted at constant $[\text{H}_2\text{O}]_{\text{vap}}$ (**a** 4500 ± 600 ppmv, **b** 6000 ± 600 ppmv) whereas alternative calibrations were conducted under low $[\text{H}_2\text{O}]_{\text{vap}}$ (< 15 ppmv). HIRAC chamber pressures between 440–1000 mbar were used to induce internal cell pressures between **(a)** 1.8–3.8 mbar and **(b)** 1.42–2.48 mbar. Error bars indicate the total uncertainty to $\pm 1\sigma$.