



Received: 2 January 2015 – Accepted: 19 March 2015 – Published: 9 April 2015

Correspondence to: M. Sipilä (mikko.sipila@helsinki.fi)

Published by Copernicus Publications on behalf of the European Geosciences Union.

**AMTD**

8, 3667–3696, 2015

**Bisulphate-cluster based atmospheric pressure chemical ionization mass spectrometer**

M. Sipilä et al.

Title Page

Abstract

Introduction

Conclusions

References

Tables

Figures



Back

Close

Full Screen / Esc

Printer-friendly Version

Interactive Discussion



## Abstract

Atmospheric amines may play a crucial role in formation of new aerosol particles via nucleation with sulphuric acid. Recent studies have revealed that concentrations below 1 ppt can significantly promote nucleation of sulphuric acid particles. While sulphuric acid detection is relatively straightforward, no amine measurements to date have been able to reach the critical sub-ppt concentration range and atmospheric amine concentrations are in general poorly characterized. In this work we present a proof-of-concept of an instrument capable of detecting dimethyl amine (DMA) with concentrations even down to 8 ppq (parts per quadrillion, 0.008 ppt) for a 15 min integration time. Detection of ammonia and amines other than dimethyl amine is discussed. We also report results from the first ambient measurements performed in spring 2013 at a boreal forest site. While minute signals from some amines were observed, DMA concentration never exceeded the detection threshold of ambient measurements (20 ppq), suggesting that it is unlikely that nucleation at this location involves DMA.

## 1 Introduction

Formation of secondary aerosol particles and cloud condensation nuclei in the atmosphere is initiated by nucleation. The role of sulphuric acid in nucleation is well established (e.g. Weber et al., 1995; Riipinen et al., 2007; Sipilä et al., 2010). However, sulphuric acid alone, or with water, does not nucleate efficiently enough to explain atmospheric nucleation rates (Kirkby et al., 2011); rather additional vapours are required to stabilize nucleating clusters. Ammonia (Ball et al., 1999; Vehkamäki et al., 2004; Kirkby et al., 2011) and amines (Kurten et al., 2008; Berndt et al., 2010; Erupe et al., 2011; Kirkby et al., 2011; Berndt et al., 2014) are proposed to act as stabilizing agents of sulphuric acid clusters in atmospheric new particle nucleation. Recently, Almeida et al. (2013) showed that dimethyl amine concentrations well below 1 ppt can dramatically enhance formation rates of new sulphuric acid particles (by several orders of

# AMTD

8, 3667–3696, 2015

## Bisulphate-cluster based atmospheric pressure chemical ionization mass spectrometer

M. Sipilä et al.

Title Page

Abstract

Introduction

Conclusions

References

Tables

Figures

◀

▶

◀

▶

Back

Close

Full Screen / Esc

Printer-friendly Version

Interactive Discussion





**Bisulphate-cluster based atmospheric pressure chemical ionization mass spectrometer**

M. Sipilä et al.

Title Page

Abstract

Introduction

Conclusions

References

Tables

Figures

◀

▶

◀

▶

Back

Close

Full Screen / Esc

Printer-friendly Version

Interactive Discussion



comparison to our present work, were also reasonably high, up to a few tens of ppt for both DMA/EA and TMA/PA. This observation is in conflict with Schobesberger et al. (2014) who measured natural ion cluster distributions at SMEAR II during nucleation and found much more ammonia than amine composition in bisulphate-sulphuric acid–base clusters. Based on that observation and targeted laboratory experiments, Schobesberger et al. (2014) concluded that DMA concentration at the site should be less than 1 ppt. Obviously, this discrepancy should be resolved.

Despite some drawbacks, atmospheric pressure chemical ionization mass spectrometry (APCI-MS) as applied by Sellegri et al., 2005 is a promising approach for ultra high sensitivity online gas phase amine detection. Nitric acid has been measured by using bisulphate ion as primary ion (Mauldin et al., 1998). For acids, such as sulphuric acid, detection limits down to 1 ppq have been achieved with the APCI-MS technique when the nitrate ion has been used as the primary ion (e.g. Eisele and Tanner, 1993; Jokinen et al., 2012). With the APCI-MS technique, interference from compounds in particle phase is minimized whereas, in techniques utilizing sample collection and subsequent analysis (e.g. LC-MS), the separation between particle and gas phases is difficult.

APCI-MS approaches in use today rely on chemical ionization by either protonated water clusters (Hanson et al., 2011) or protonated ethanol or acetone (Yu et al., 2012). Product ions which are guided through a differentially pumped section comprising collision dissociation chamber and an octopole ion guide are subsequently detected by a quadrupole mass spectrometer (Hanson et al., 2011; Yu et al., 2012). Using the above technique with protonated ethanol, Yu et al. (2013) reported a limit of detection (LOD) of 7 ppt for dimethyl amine and from 8 to 41 ppt for a series of other small alkyamines. Hanson et al. (2011) reported amine detection at “sub-ppt” levels by means of protonated water cluster ionization. This sub-ppt measurement range is still above the ppq range reachable in case of  $\text{NO}_3^-$ -ionization detection of strong acids. These approaches may also suffer from flaws interfering with reliable amine detection and quantification: (i) outgassing of amines from gas lines and surfaces of chemical ionization system, (ii) non-collision limit charging efficiency, and (iii) uncertainty in identi-

**Bisulphate-cluster based atmospheric pressure chemical ionization mass spectrometer**

M. Sipilä et al.

Title Page

Abstract

Introduction

Conclusions

References

Tables

Figures

◀

▶

◀

▶

Back

Close

Full Screen / Esc

Printer-friendly Version

Interactive Discussion

fication of the elemental composition of detected ion due to insufficient mass resolution of the quadrupole mass spectrometer. Further problems in high sensitivity amine measurements can be caused by amine contamination in the zero gas required for determination of instrument background.

5 Here we describe a chemical ionization system that utilizes ion induced clustering of sulphuric acid and amines or ammonia, with ions detected with an atmospheric pressure interface time-of-flight mass spectrometer (APi-TOF, Junninen et al., 2010). This approach addresses the above issues that can complicate amine detection. Instrument response to ammonia and dimethyl amine was studied by calibrations performed in the  
10 CLOUD facility at CERN (e.g. Kirkby et al., 2011; Almeida et al., 2013). The instrument was used for quantification of ammonia and dimethyl amine as well as for qualitative detection of other amines in CLOUD at CERN and at the SMEAR II boreal forest field station in Hyytiälä, southern Finland, during the PEGASOS campaign in spring 2013.

## 2 Instrument

15 The instrument uses the nitrate ion atmospheric pressure chemical ionization (CI) system combined with an APi-TOF (Junninen et al., 2010) as described in Jokinen et al. (2012). Two modifications were made to the original instrument (Jokinen et al., 2012). First, due to multiple problems associated with use and transportation of radioactive materials, the radioactive 10 MBq Am-241 ion source was replaced by  
20 a Hamamatsu (model L9490) soft ( $< 9.5$  keV) X-ray tube. Second, a system for introducing gaseous sulphuric acid ( $\text{H}_2\text{SO}_4$ ) in the sample flow was developed. A schematic representation of the instrument is shown in Fig. 1.

Operation of the chemical ionization-ion induced nucleation inlet is based on chemical ionization of sulphuric acid,  $\text{H}_2\text{SO}_4$  ( $\equiv \text{SA}$ ) by nitrate ions,  $\text{NO}_3^-$ , to form bisulphate ions,  $\text{HSO}_4^-$  ( $\equiv \text{SA}^-$ ), and subsequent formation of bisulphate ion-sulphuric acid clus-

ters:



5 In presence of dimethyl amine (DMA):



Further clustering of sulphuric acid takes place:

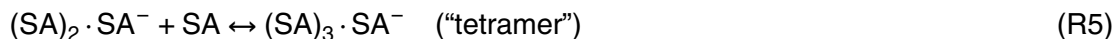

After which, besides DMA, ammonia ( $\text{NH}_3$ ) can also stick to the clusters

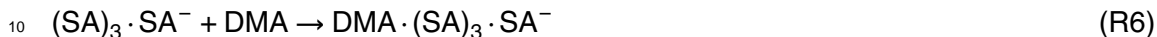

If sufficient sulphuric acid is present in the ambient sample it is possible that DMA (at very low concentrations) is bound to sulphuric acid. In that case the following reaction can also occur:

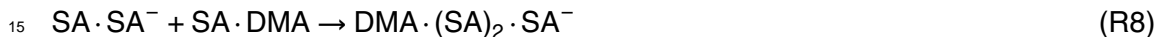

Clusters formed in Reactions (R2)–(R8) can also decompose (evaporate), specifically in the reduced pressure in the API interface to the mass spectrometer. Evaporation rates for Reactions (R1)–(R8) at +25 °C have been calculated to be: Reaction (R2):  $2.70 \times 10^{-15}$ , Reaction (R3):  $5.60 \times 10^{-3}$ , Reactions (R4) and (R8):  $5.28 \times 10^{-2}$ , Reaction (R5): 24.1, Reaction (R6): 1.89 and Reaction (R7):  $27.4 \text{ s}^{-1}$  (Ortega et al., 2014). In Reactions (R2)–(R4) and (R8), only the forward reaction needs to be considered. Due to their highly negative formation free energy, clusters formed in these reactions should be virtually non-evaporating in the 0.1 s residence time the CI-system.

## Bisulphate-cluster based atmospheric pressure chemical ionization mass spectrometer

M. Sipilä et al.

Title Page

Abstract

Introduction

Conclusions

References

Tables

Figures

◀

▶

◀

▶

Back

Close

Full Screen / Esc

Printer-friendly Version

Interactive Discussion







concentration in the system is significantly higher than that of the “tetramer” and larger sulphuric acid clusters.

Figure 3 shows the operation of the  $\text{NO}_3^-$  CI-system in more detail (Eisele and Tanner, 1993; Jokinen et al., 2012), including COMSOL computational fluid dynamical modeling. The system is comprised of a 3/4 inch inlet tube through which the sample is drawn with a flow rate of 10 lpm. A cylinder (coaxial to the inlet tube) is held at  $-130$  V potential, separating the ion production region from the sample tube at ground potential. Still coaxial to that is an outer cylinder also kept at  $-130$  V potential. An X-ray source irradiates the space between these two cylinders through an aluminium window at outer cylinder surface.

Sheath gas (ideally cryogenic  $\text{N}_2$ ) flows at 20 lpm in the air space between the cylinders and carries the ions produced in the ion production region downstream toward the ion-molecule reaction (IMR) tube.  $\text{HNO}_3$  vapor added into the sheath flow promptly converts ions (formed from the X-rays) to  $\text{NO}_3^- (\text{HNO}_3)_{n,n=0-2}$  ions or ion clusters. After entering the IMR region, an electric field ( $-110$  V) between the IMR tube and the ground potential of the sample tube pushes the ions toward the sample (centerline) flow. Flows (sheath and sample) and electric field strength are balanced so that ions do not hit the sample tube wall, rather following an axial trajectory after entering the sample flow. Ions then interact with the sample flow for up to 340 ms before the electric field guides the ions into the 0.7 lpm flow through the pinhole into the atmospheric pressure interface of the TOF mass spectrometer.

The upper panel of Fig. 3 shows the flow velocity profile and nitrate ion trajectory in absence of any electric potential in the drift tube or in the ion source. Ions travel close to the wall of the drift tube and exit the system with excess flow without interacting with the sample flow. In this case ions do not enter the mass spectrometer. The lower panel of Fig. 3 depicts the electric potential and the nitrate ion trajectory with the electric field on. The electric field and gas flows guide the ions from the ion production region to the centerline of the drift tube and eventually through the pinhole into the APi-TOF. This nitrate ion based CI-APi-TOF has been used in many recent laboratory and ambient

**Bisulphate-cluster based atmospheric pressure chemical ionization mass spectrometer**

M. Sipilä et al.

Title Page

Abstract

Introduction

Conclusions

References

Tables

Figures

◀

▶

◀

▶

Back

Close

Full Screen / Esc

Printer-friendly Version

Interactive Discussion



air studies probing atmospheric chemistry and particle formation (e.g. Mauldin et al., 2012; Almeida et al., 2013; Ehn et al., 2014; Kürten et al., 2014). It has shown to be highly sensitive toward sulphuric acid, sulphuric acid-amine clusters, and highly oxidized low volatility organics.

5 However,  $\text{NO}_3^-$  chemistry is inapplicable for direct amine measurements; bisulphate-sulphuric acid clusters need to be generated. Therefore, preceding the nitrate CI-system, a flow (1–2 lpm) saturated in sulphuric acid vapour is mixed with the sample air. The saturator is a temperature controlled ( $+20^\circ\text{C}$ ) rotating coaxial design (Fig. 4).  
10 The coaxial design allows a significantly more compact construction than a cylindrical design, while rotation continuously wets the walls with liquid sulphuric acid. This minimized unwanted wall effects; e.g. clean glass surfaces act as a sink to sulphuric acid vapour in contrast to liquid acid coatings. The glass tube connecting the rotating saturator to the sample inlet is as short as possible (5 cm). Mixing of sulphuric acid vapor and the sample gas then takes place in the 20 cm distance before the sample air enters the drift tube/ion interaction region. The detailed mixing process is not well known; it most likely involves both small scale turbulence and diffusion. Sulphuric acid concentration in the resulting mixture is in the range of  $2\text{--}6 \times 10^{10}$  molecules  $\text{cm}^{-3}$ . After entering the IMR tube, Reactions (R1)–(R8) result in prompt formation of bisulphate-sulphuric acid–base clusters for mass spectrometric analysis. Neutral sulphuric acid–base nucleation  
20 can occur both in the sample tube as well as in the IMR tube; in the latter, ionization of neutral clusters by  $\text{NO}_3^-$  or  $\text{SA}^-$  can also occur. However, since ion induced clustering is significantly faster (due ion enhanced collision rate) than neutral cluster formation, neutral processes likely play a minor role.

25 Problems that have previously limited amine measurements (see Introduction) are, to a large extent, solved with the present approach. Firstly: (i) outgassing of amines from flow system walls is effectively prevented by acid coating of all gas lines and CI-source surfaces. Stainless steel surfaces in the sheath gas line are also extensively coated with  $\text{HNO}_3$  added to sheath gas flow. Such acid coating activates tube walls

## Bisulphate-cluster based atmospheric pressure chemical ionization mass spectrometer

M. Sipilä et al.

Title Page

Abstract

Introduction

Conclusions

References

Tables

Figures

◀

▶

◀

▶

Back

Close

Full Screen / Esc

Printer-friendly Version

Interactive Discussion



with respect to base deposition and prevent desorption. Only the wall of 3/4 inch dia. 40 cm long inlet tube extending to ambient atmosphere is not actively acidified.

Second problem, (ii) non-collision limit charging efficiency, is solved for DMA by the choice of the ionization method. DMA sticks to sulphuric acid trimer and tetramer without significant evaporation. This, however, is not the case with ammonia. Other amines also need to be thoroughly investigated.

Third problem, (iii) identification of the atomic composition of detected ion is solved by application of high mass resolution TOF mass spectrometer. Mass resolution of APi-TOF is  $\sim 4000 \text{ ThTh}^{-1}$  and mass accuracy is  $< 20 \text{ ppm}$ . This is facilitated in data post-processing utilizing high-resolution peak identification and isotopic patterns (tofTools, Junninen et al., 2010). Combined with high selectivity of the ionization method, many unwanted compounds are not ionized, or resolved in a very clean mass spectrum.

### 3 Sensitivity studies

Sensitivity was studied in the CLOUD experiment at CERN. For a detailed description of the facility see Kirkby et al. (2011) and Almeida et al. (2013). Briefly, the CLOUD facility is designed for studying nucleation and growth of secondary aerosol, cloud droplet activation and freezing and the effect of galactic cosmic radiation on those processes, under precisely defined laboratory conditions. The CLOUD-chamber itself is a  $26 \text{ m}^3$  electropolished stainless steel tank equipped with a UV-light system and precise temperature control. Lifetime of condensable gases against wall loss is in the range of few minutes. Air inside the chamber is prepared from cryogenic nitrogen and oxygen. Input gases are precisely controlled and the gas composition is continuously monitored by an extensive suite of analyzing instruments.

DMA and/or  $\text{NH}_3$  were mixed with the flows of cryogenic oxygen and nitrogen, prior entering the chamber. Concentrations of bases were calculated from the mixing ratio of the flows and confirmed by measurement with ion chromatography ( $> 1.0 \text{ pptv}$  for DMA and  $> 3.7 \text{ ppt}$  for  $\text{NH}_3$ ; Praplan et al., 2012, Bianchi et al., 2012).

## Bisulphate-cluster based atmospheric pressure chemical ionization mass spectrometer

M. Sipilä et al.

Title Page

Abstract

Introduction

Conclusions

References

Tables

Figures

◀

▶

◀

▶

Back

Close

Full Screen / Esc

Printer-friendly Version

Interactive Discussion



### 3.1 Sensitivity for DMA

The CIMS system described in this work was calibrated against the concentration in the CLOUD chamber with [DMA] ranging from 0.25 to 4 ppt. These experiments included simultaneous generation of sulphuric acid (from SO<sub>2</sub> oxidation) at atmospheric levels to investigate of sulphuric acid–DMA nucleation. Sulphuric acid present in the chamber could affect DMA detection via clustering with the DMA which could slightly affect the measurement to a pure DMA system. However, since sulphuric acid concentrations were representative of the atmosphere, the presence of sulphuric acid makes the calibration system more atmospherically relevant. In Fig. 5, example mass spectra around mass/charge 436 Th, the mass of the DMA-tetramer cluster, show signals with [DMA] = 0.25 ppt and with no added DMA (i.e. chemical background of the system with CLOUD tank cleaned and filled with cryogenic N<sub>2</sub>/O<sub>2</sub> mixture). The main isotope at 437.92 Th is clearly visible demonstrating the sensitivity and the resolution of the method. The isotopic distribution and the exact mass of the main peak allow unambiguous identification of the atomic composition of the cluster ion.

Response of the instrument as a function of [DMA] is shown in Fig. 6. DMA is observed in the clusters with (SA)<sub>2-4</sub>·SA<sup>-</sup>, with DMA·(SA)<sub>3</sub>·SA<sup>-</sup> being the most abundant cluster. Summing up the detected clusters yields the total signal of DMA. Signal is normalized by (SA)<sub>2</sub>·SA<sup>-</sup>, the dominant reagent ion at the end of the IMR tube. (SA)<sub>2</sub>·SA<sup>-</sup> should be the ion to which most of the DMA attach according to Reaction (R4) (before the further attachment of sulphuric acid), since DMA cannot attach to (SA)<sub>0-1</sub>·SA<sup>-</sup> and larger clusters (SA)<sub>>2</sub>·SA<sup>-</sup> are far more sparse. It is possible that significant fraction of neutral DMA molecules enter the IMR region bound to sulphuric acid. In that case, Reaction (R8) can play a role as well, and normalization to sum of bisulphate dimer and trimer might be appropriate. However, the results in Fig. 6 are independent on the choice of normalization method.

All detected ions correlate extremely well with the DMA concentration calculated from the flows injected in the chamber. The correlation between the normalized sum

## AMTD

8, 3667–3696, 2015

### Bisulphate-cluster based atmospheric pressure chemical ionization mass spectrometer

M. Sipilä et al.

Title Page

Abstract

Introduction

Conclusions

References

Tables

Figures

◀

▶

◀

▶

Back

Close

Full Screen / Esc

Printer-friendly Version

Interactive Discussion











## Bisulphate-cluster based atmospheric pressure chemical ionization mass spectrometer

M. Sipilä et al.

strated that, under ideal conditions, a limit of detection for dimethyl amine (DMA) of 8 ppq. Sensitivity of the system for DMA is approximately hundred-fold higher than reported for other existing methods. Superior performance results from minimization of amine outgassing from system surfaces, collision limited ionization detection and high mass resolution of the applied mass spectrometer. Extreme cleanliness of added gas flows is also critical.

Besides DMA, other small alkyl amines and ammonia are detected. Detection of ammonia with the present system, however, suffers from imperfect temperature control resulting in varying stability of bisulphate-sulphuric acid–ammonia clusters which is likely reflected in variable instrument response. Further efforts are required to understand the clustering dynamics of amines other than DMA and to calibrate instrument against well quantified concentration of these amines. In field measurements at a boreal forest site, DMA concentration was below  $\sim 20$  ppq throughout the whole measurement period in May–June 2013, suggesting that it is unlikely that DMA played a major role in atmospheric nucleation of new aerosol particles observed simultaneously at the site. However, tentative observation on the existence of other amines (trimethyl and/or propyl amine) leaves open the possibility of amine contribution to new particle formation.

*Acknowledgements.* We thank CERN for supporting CLOUD with technical and financial resources. Support of Academy of Finland (251427, 139656, 264375, Finnish Center of Excellence 141135) is acknowledged. This research was partially funded by the European Commission 7th Frame work Programme via PEGASOS (FP7-ENV-2010-265148), ACTRIS (Aerosols, Clouds, and Trace gases Research InfraStructure Network), Marie Curie Initial Training Network “CLOUD-ITN” and “CLOUDTRAIN-ITN” and Finnish Funding Agency for Innovation (TEKES) through APCI-project. Tinja Olenius, Oona Kupiainen-Määttä, Kenty Ortega, Hanna Vehkamäki, Antti-Jussi Kieloaho and Markku Kulmala are acknowledged for useful discussions. We thank the tofTools team for providing tools for mass spectrometry analysis. Finnish Antarctic Research Program is acknowledged for providing superior facilities for preparing the manuscript.

Title Page

Abstract

Introduction

Conclusions

References

Tables

Figures

◀

▶

◀

▶

Back

Close

Full Screen / Esc

Printer-friendly Version

Interactive Discussion



## References

- Almeida, J., Schobesberger, S., Kurten, A., Ortega, I. K., Kupiainen-Määttä, O., Praplan, A. P., Adamov, A., Amorim, A., Bianchi, F., Breitenlechner, M., David, A., Dommen, J., Donahue, N. M., Downard, A., Dunne, E., Duplissy, J., Ehrhart, S., Flagan, R. C., Franchin, A., Guida, R., Hakala, J., Hansel, A., Heinritzi, M., Henschel, H., Jokinen, T., Junninen, H., Kajos, M., Kangasluoma, J., Keskinen, H., Kupc, A., Kurten, T., Kvashin, A. N., Laaksonen, A., Lehtipalo, K., Leiminger, M., Leppä, J., Loukonen, V., Makhmutov, V., Mathot, S., McGrath, M. J., Nieminen, T., Olenius, T., Onnela, A., Petäjä, T., Riccobono, F., Riipinen, I., Rissanen, M., Rondo, L., Ruuskanen, T., Santos, F. D., Sarnela, N., Schallhart, S., Schnitzhofer, R., Seinfeld, J. H., Simon, M., Sipilä, M., Stozhkov, Y., Stratmann, F., Tome, A., Trostl, J., Tsagkogeorgas, G., Vaattovaara, P., Viisanen, Y., Virtanen, A., Vrtala, A., Wagner, P. E., Weingartner, E., Wex, H., Williamson, C., Wimmer, D., Ye, P. L., Yli-Juuti, T., Carslaw, K. S., Kulmala, M., Curtius, J., Baltensperger, U., Worsnop, D. R., Vehkamäki, H., and Kirkby, J.: Molecular understanding of sulphuric acid-amine particle nucleation in the atmosphere, *Nature*, 502, 359–363, 2013.
- Ball, S. M., Hanson, D. R., Eisele, F. L., and McMurry, P. H.: Laboratory studies of particle nucleation: initial results for  $\text{H}_2\text{SO}_4$ ,  $\text{H}_2\text{O}$ , and  $\text{NH}_3$  vapors, *J. Geophys. Res.*, 104, 23709–23718, 1999.
- Berndt, T., Stratmann, F., Sipilä, M., Vanhanen, J., Petäjä, T., Mikkilä, J., Grüner, A., Spindler, G., Lee Mauldin III, R., Curtius, J., Kulmala, M., and Heintzenberg, J.: Laboratory study on new particle formation from the reaction  $\text{OH} + \text{SO}_2$ : influence of experimental conditions,  $\text{H}_2\text{O}$  vapour,  $\text{NH}_3$  and the amine tert-butylamine on the overall process, *Atmos. Chem. Phys.*, 10, 7101–7116, doi:10.5194/acp-10-7101-2010, 2010.
- Bianchi, F., Dommen, J., Mathot, S., and Baltensperger, U.: On-line determination of ammonia at low pptv mixing ratios in the CLOUD chamber, *Atmos. Meas. Tech.*, 5, 1719–1725, doi:10.5194/amt-5-1719-2012, 2012.
- Ehn, M., Thornton, J. A., Kleist, E., Sipilä, M., Junninen, H., Pullinen, I., Springer, M., Rubach, F., Tillmann, R., Lee, B., Lopez-Hilfiker, F., Andres, S., Acir, I.-H., Rissanen, M., Jokinen, T., Schobesberger, S., Kangasluoma, J., Kontkanen, J., Nieminen, T., Kurtén, T., Nielsen, L. B., Jørgensen, S., Kjaergaard, H. G., Canagaratna, M., Dal Maso, M., Berndt, T., Petäjä, T., Wahner, A., Kerminen, V., Kulmala, M., Worsnop, D. R., Wildt, J., and Mentel, T. F.: A large source of low-volatility secondary organic aerosol, *Nature*, 506, 476–479, 2014.

## AMTD

8, 3667–3696, 2015

### Bisulphate-cluster based atmospheric pressure chemical ionization mass spectrometer

M. Sipilä et al.

Title Page

Abstract

Introduction

Conclusions

References

Tables

Figures

◀

▶

◀

▶

Back

Close

Full Screen / Esc

Printer-friendly Version

Interactive Discussion

**Bisulphate-cluster based atmospheric pressure chemical ionization mass spectrometer**

M. Sipilä et al.

Title Page

Abstract

Introduction

Conclusions

References

Tables

Figures

◀

▶

◀

▶

Back

Close

Full Screen / Esc

Printer-friendly Version

Interactive Discussion



Eisele, F. L. and Tanner, D. J.: Measurement of the gas phase concentration of H<sub>2</sub>SO<sub>4</sub> and methane sulfonic acid and estimates of H<sub>2</sub>SO<sub>4</sub> production and loss in the atmosphere, *J. Geophys. Res.*, 98, 9001–9010, 1993.

Erupe, M. E., Viggiano, A. A., and Lee, S.-H.: The effect of trimethylamine on atmospheric nucleation involving H<sub>2</sub>SO<sub>4</sub>, *Atmos. Chem. Phys.*, 11, 4767–4775, doi:10.5194/acp-11-4767-2011, 2011.

Freshour, N. A., Carlson, K. K., Melka, Y. A., Hinz, S., Panta, B., and Hanson, D. R.: Amine permeation sources characterized with acid neutralization and sensitivities of an amine mass spectrometer, *Atmos. Meas. Tech.*, 7, 3611–3621, doi:10.5194/amt-7-3611-2014, 2014.

Ge, X., Wexler, A. S., and Clegg, S. L.: Atmospheric amines – Part I. A review, *Atmos. Environ.*, 45, 524–546, 2010.

Grönberg, L., Lövkvist, P., and Jönsson, J. A.: Measurement of aliphatic amines in ambient air and rainwater, *Chemosphere*, 24, 1533–1540, 1992.

Hanson, D. R., McMurry, P. H., Jiang, J., Tanner, D., and Huey, L. G.: Ambient pressure proton transfer mass spectrometry: detection of amines and ammonia, *Environ. Sci. Technol.*, 45, 8881–8888, 2011.

Hari, P. and Kulmala, M.: Station for measuring ecosystem–atmosphere relations (SMEAR II), *Boreal Environ. Res.*, 10, 315–322, 2005.

Jokinen, T., Sipilä, M., Junninen, H., Ehn, M., Lönn, G., Hakala, J., Petäjä, T., Mauldin III, R. L., Kulmala, M., and Worsnop, D. R.: Atmospheric sulphuric acid and neutral cluster measurements using CI-API-TOF, *Atmos. Chem. Phys.*, 12, 4117–4125, doi:10.5194/acp-12-4117-2012, 2012.

Junninen, H., Ehn, M., Petäjä, T., Luosujärvi, L., Kotiaho, T., Kostianen, R., Rohner, U., Gonin, M., Fuhrer, K., Kulmala, M., and Worsnop, D. R.: A high-resolution mass spectrometer to measure atmospheric ion composition, *Atmos. Meas. Tech.*, 3, 1039–1053, doi:10.5194/amt-3-1039-2010, 2010.

Kieloaho, A.-J., Hellén, H., Hakola, H., Manninen, H.-E., Nieminen, T., Kulmala, M., and Pihlatie, M.: Gas-phase alkylamines in a boreal Scots pine forest air, *Atmos. Environ.*, 80, 369–377, 2013.

Kirkby, J., Curtius, J., Almeida, J., Dunne, E., Duplissy, J., Ehrhart, S., Franchin, A., Gagne, S., Ickes, L., Kürten, A., Kupc, A., Metzger, A., Riccobono, F., Rondo, L., Schobesberger, S., Tsagkogeorgas, G., Wimmer, D., Amorim, A., Bianchi, F., Breitenlechner, M., David, A., Dommen, J., Downard, A., Ehn, M., Flagan, R. C., Haider, S., Hansel, A., Hauser, D., Jud, W.,



**Bisulphate-cluster based atmospheric pressure chemical ionization mass spectrometer**

M. Sipilä et al.

Title Page

Abstract

Introduction

Conclusions

References

Tables

Figures

◀

▶

◀

▶

Back

Close

Full Screen / Esc

Printer-friendly Version

Interactive Discussion



Praplan, A. P., Bianchi, F., Dommen, J., and Baltensperger, U.: Dimethylamine and ammonia measurements with ion chromatography during the CLOUD4 campaign, *Atmos. Meas. Tech.*, 5, 2161–2167, doi:10.5194/amt-5-2161-2012, 2012.

Riipinen, I., Sihto, S.-L., Kulmala, M., Arnold, F., Dal Maso, M., Birmili, W., Saarnio, K., Teinilä, K., Kerminen, V.-M., Laaksonen, A., and Lehtinen, K. E. J.: Connections between atmospheric sulphuric acid and new particle formation during QUEST III–IV campaigns in Heidelberg and Hyytiälä, *Atmos. Chem. Phys.*, 7, 1899–1914, doi:10.5194/acp-7-1899-2007, 2007.

Schobesberger, S., Franchin, A., Bianchi, F., Rondo, L., Duplissy, J., Kürten, A., Ortega, I. K., Metzger, A., Schnitzhofer, R., Almeida, J., Amorim, A., Dommen, J., Dunne, E. M., Ehn, M., Gagné, S., Ickes, L., Junninen, H., Hansel, A., Kerminen, V.-M., Kirkby, J., Kupc, A., Laaksonen, A., Lehtipalo, K., Mathot, S., Onnela, A., Petäjä, T., Riccobono, F., Santos, F. D., Sipilä, M., Tomé, A., Tsagkogeorgas, G., Viisanen, Y., Wagner, P. E., Wimmer, D., Curtius, J., Donahue, N. M., Baltensperger, U., Kulmala, M., and Worsnop, D. R.: On the composition of ammonia–sulphuric-acid ion clusters during aerosol particle formation, *Atmos. Chem. Phys.*, 15, 55–78, doi:10.5194/acp-15-55-2015, 2015.

Sellegrì, K., Hanke, M., Umann, B., Arnold, F., and Kulmala, M.: Measurements of organic gases during aerosol formation events in the boreal forest atmosphere during QUEST, *Atmos. Chem. Phys.*, 5, 373–384, doi:10.5194/acp-5-373-2005, 2005.

Sipilä, M., Berndt, T., Petäjä, T., Brus, D., Vanhanen, J., Stratmann, F., Patokoski, J., Mauldin, L., Hyvärinen, A.-P., Lihavainen, H., and Kulmala, M.: The role of sulphuric acid in atmospheric nucleation, *Science*, 327, 1243–1246, 2010.

Vehkamäki, H., Napari, I., Kulmala, M., and Noppel, M.: Stable ammonium bisulphate clusters in the atmosphere, *Phys. Rev. Lett.*, 93, 148501, doi:10.1103/PhysRevLett.93.148501, 2004.

Weber, R. J., McMurry, P. H., Eisele, F. L., and Tanner, D. J.: Measurement of expected nucleation precursor species and 3–500-nm diameter particles at Mauna Loa observatory, Hawaii, *J. Atmos. Sci.*, 52, 2242–2257, 1995.

Yu, H., McGraw, R., and Lee, S.-H.: Effects of amines on formation of sub-3 nm particles and their subsequent growth, *Geophys. Res. Lett.*, 39, L02807, doi:10.1029/2011GL050099, 2012.

## Bisulphate-cluster based atmospheric pressure chemical ionization mass spectrometer

M. Sipilä et al.

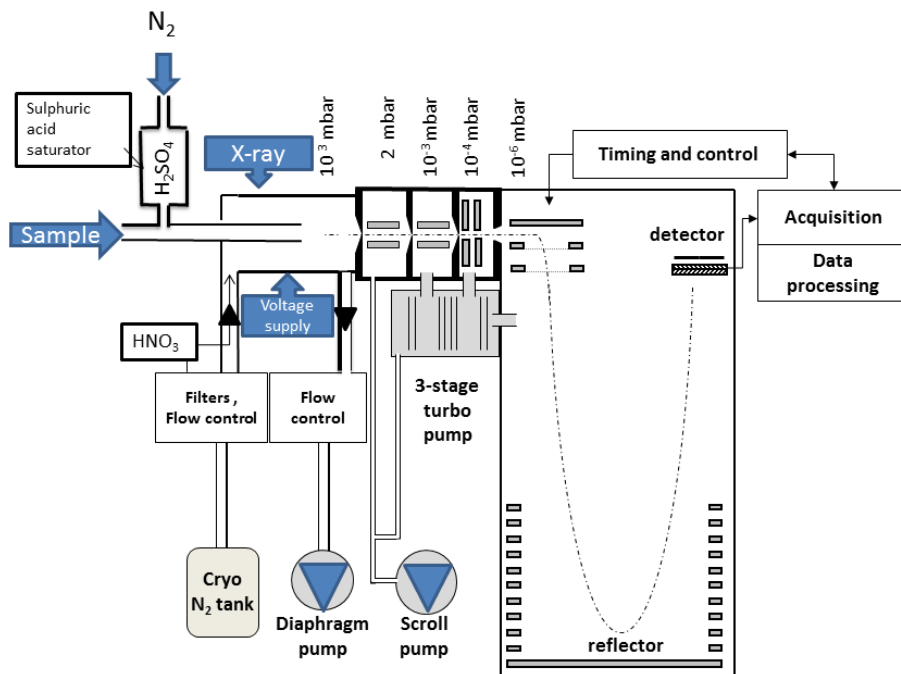

**Figure 1.** Schematic of the bisulphate-cluster chemical ionization atmospheric pressure interface time-of-flight mass spectrometer.

Title Page

Abstract

Introduction

Conclusions

References

Tables

Figures

◀

▶

◀

▶

Back

Close

Full Screen / Esc

Printer-friendly Version

Interactive Discussion

**Bisulphate-cluster based atmospheric pressure chemical ionization mass spectrometer**

M. Sipilä et al.

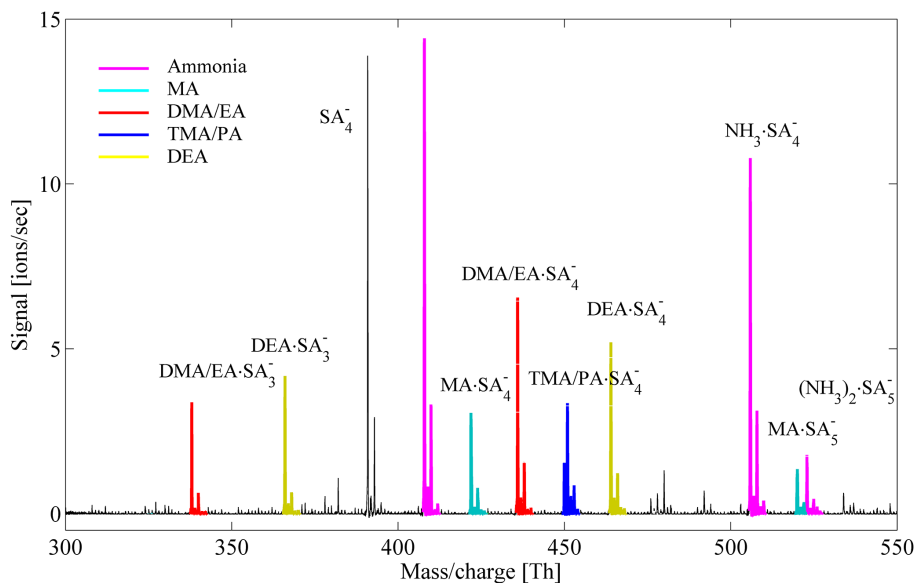
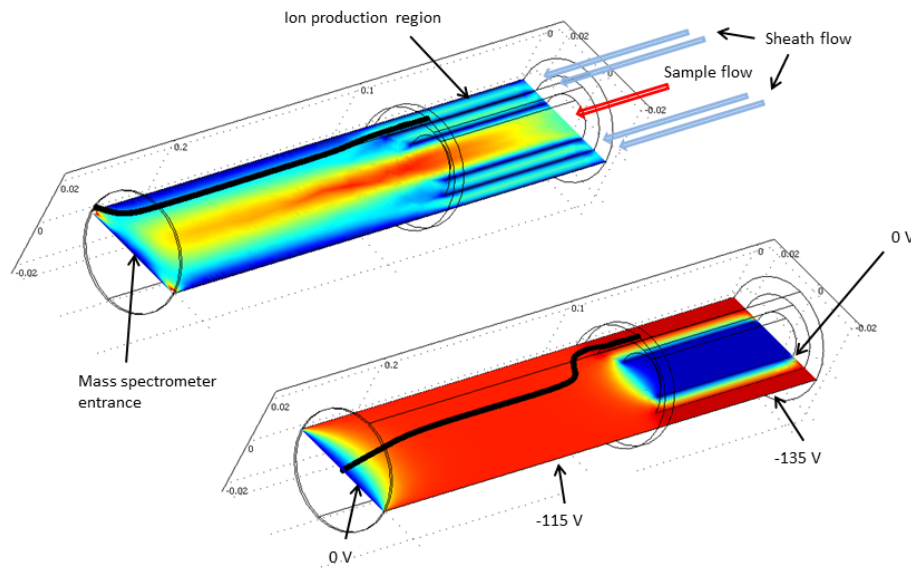

**Figure 2.** Dimethyl (DMA) and/or ethyl amine (EA) and diethyl amine (DEA) form stable clusters already with bisulphate “trimer”, whereas ammonia, methyl amine (MA) and trimethyl/propyl amine (TMA/PA) are detected with “tetramer” or larger clusters.

[Title Page](#)[Abstract](#)[Introduction](#)[Conclusions](#)[References](#)[Tables](#)[Figures](#)[◀](#)[▶](#)[◀](#)[▶](#)[Back](#)[Close](#)[Full Screen / Esc](#)[Printer-friendly Version](#)[Interactive Discussion](#)

## Bisulphate-cluster based atmospheric pressure chemical ionization mass spectrometer

M. Sipilä et al.

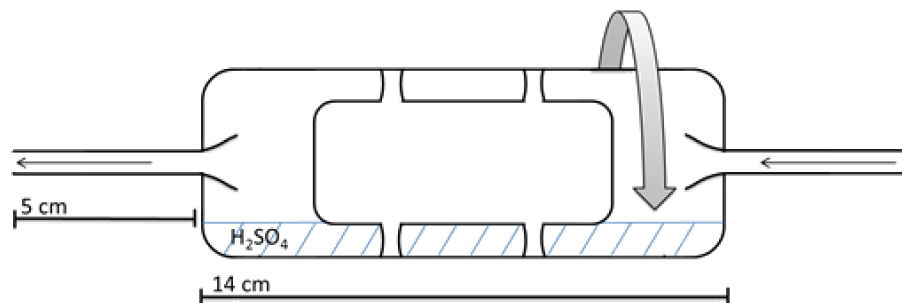

**Figure 3.** Operation principle of  $\text{NO}_3^-$  CI-system used to produce bisulphate-sulphuric acid–base clusters from ambient amines and added sulphuric acid present in the sample flow. Upper plot represents the flow profile inside the system. Lower plot depicts the electric potential inside the system. In upper panel, black thick line shows the ion trajectory in the case where all electric potentials are set to zero and ions “go with the flow”. In lower panel, the black thick line shows electric fields guiding ions toward the centerline of the ion source, allowing ions to mix and interact with the sample and eventually be transported to the pinhole of the mass spectrometer. Original concept as presented by Eisele and Tanner (1993) was adopted by Jokinen et al. (2012) and coupled to the APi-TOF mass spectrometer.



**Bisulphate-cluster based atmospheric pressure chemical ionization mass spectrometer**

M. Sipilä et al.



**Figure 4.** Schematic of the rotating sulphuric acid saturator. The saturator is connected to the sample tube as in Fig. 1.

Title Page

Abstract

Introduction

Conclusions

References

Tables

Figures

◀

▶

◀

▶

Back

Close

Full Screen / Esc

Printer-friendly Version

Interactive Discussion



**Bisulphate-cluster based atmospheric pressure chemical ionization mass spectrometer**

M. Sipilä et al.

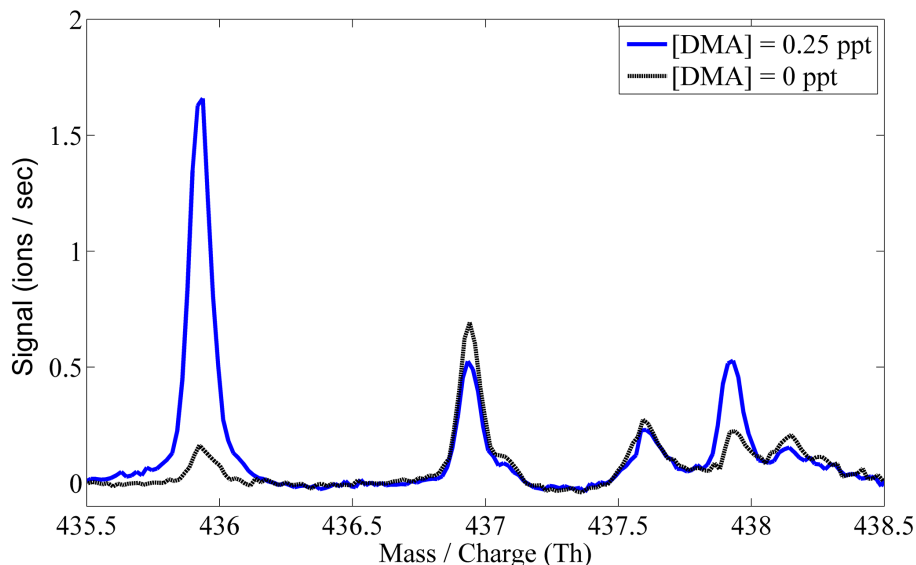
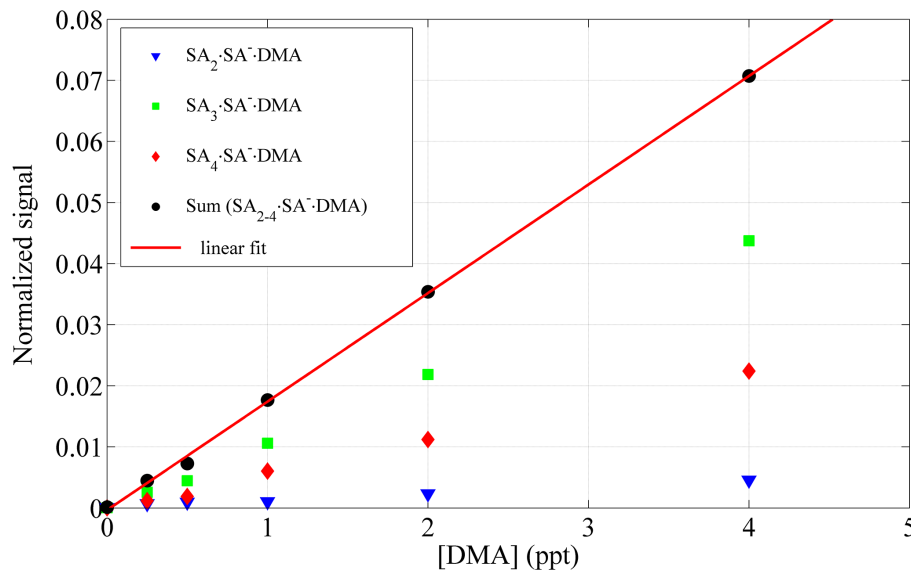

**Figure 5.** Mass spectra with [DMA] = 0.25 ppt, the lowest studied [DMA]; and the background signal (in absence of added DMA). Integration time is 15 min. Principal peak is located at 435.92 Th, first of the isotopes 436.92 Th is partly overlapping with signal from an unidentified compound. Second isotope at 437.92 Th is, however, clearly visible. Signal at 437.6 Th emerges from chlorine containing substance, whose source is unknown. Lowest detection limit was defined as three times the background signal at main peak (435.92 Th) and was found to be 8 ppq (0.008 ppt). Practically, ultimate sensitivity is limited by contamination in blank air or inlet surfaces.

[Title Page](#)[Abstract](#)[Introduction](#)[Conclusions](#)[References](#)[Tables](#)[Figures](#)[◀](#)[▶](#)[◀](#)[▶](#)[Back](#)[Close](#)[Full Screen / Esc](#)[Printer-friendly Version](#)[Interactive Discussion](#)

**Bisulphate-cluster based atmospheric pressure chemical ionization mass spectrometer**

M. Sipilä et al.

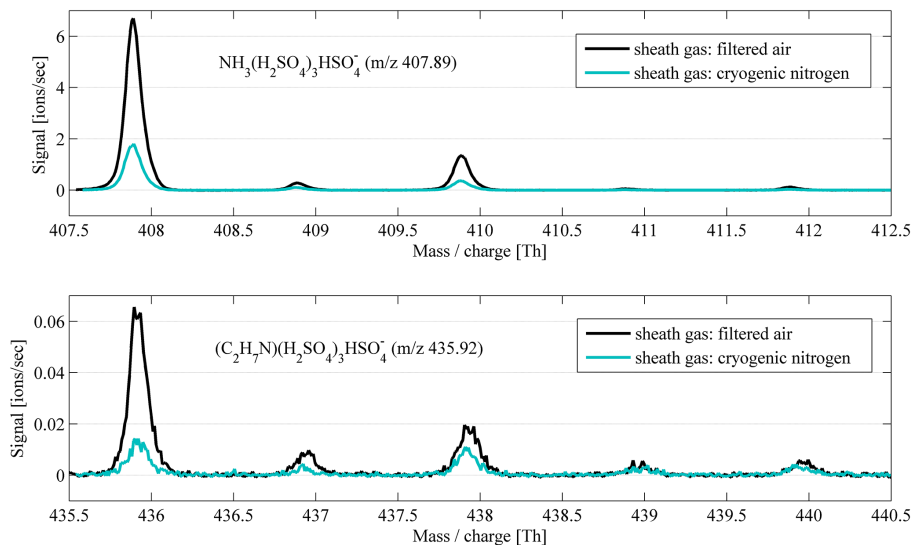

**Figure 6.** Response of bisulphate cluster signal to [DMA] = 0–4 ppt. DMA concentration in the CLOUD tank was adjusted by adjusting the DMA containing flow to the chamber.

[Title Page](#)[Abstract](#)[Introduction](#)[Conclusions](#)[References](#)[Tables](#)[Figures](#)[◀](#)[▶](#)[◀](#)[▶](#)[Back](#)[Close](#)[Full Screen / Esc](#)[Printer-friendly Version](#)[Interactive Discussion](#)

**Bisulphate-cluster based atmospheric pressure chemical ionization mass spectrometer**

M. Sipilä et al.



**Figure 7.** Purity of sheath gas is important for high sensitivity detection. Cryogenic  $\text{N}_2$  resulted in 3–5 times lower background than ambient air filtered with particle filter and amine specific gas mask filter. Still both ammonia and dimethyl amine are visible in the spectra, with signals corresponding to several tens of ppt for ammonia and  $\sim 10$  ppq for dimethyl amine. Data are taken with zero air ( $\text{N}_2$ ) fed in the sample inlet.

Title Page

Abstract

Introduction

Conclusions

References

Tables

Figures

◀

▶

◀

▶

Back

Close

Full Screen / Esc

Printer-friendly Version

Interactive Discussion

**Bisulphate-cluster based atmospheric pressure chemical ionization mass spectrometer**

M. Sipilä et al.

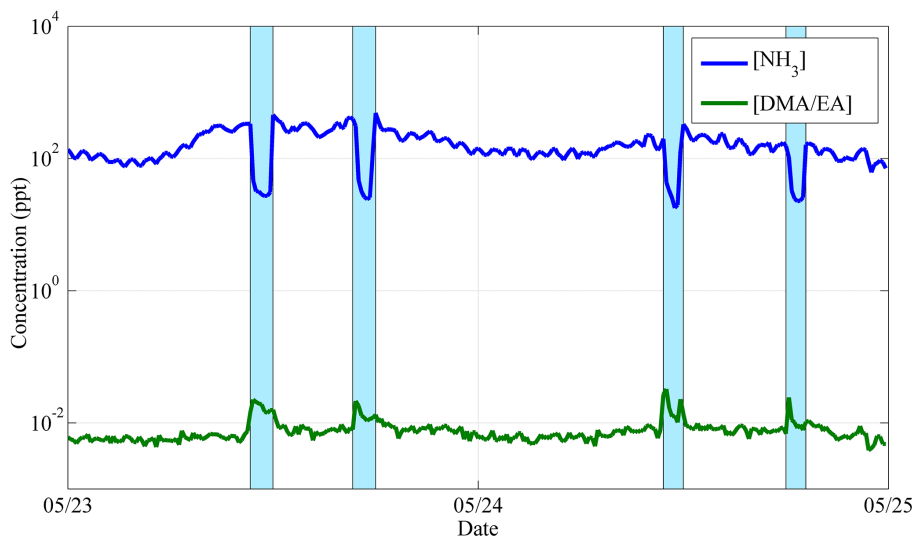
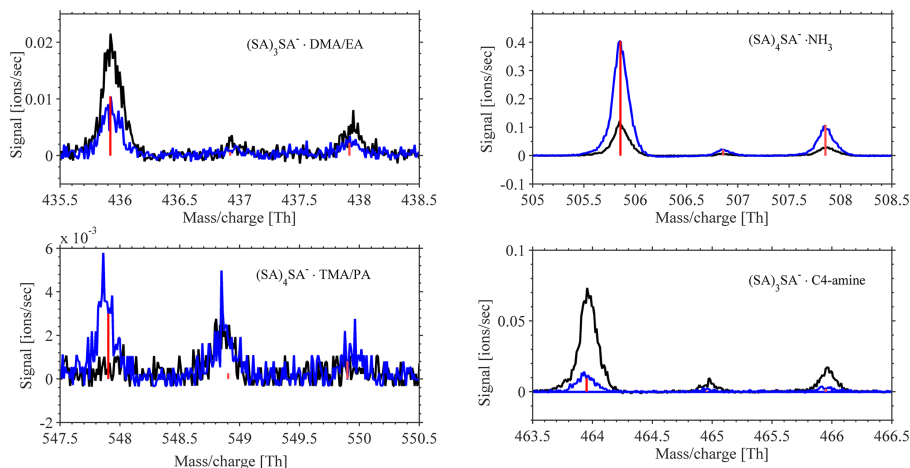

**Figure 8.** Portion of time series measured at SMEAR II boreal forest field station. While ammonia concentration exceeds the detection threshold determined by the zero measurement, DMA signal increases when zero air is fed in the instrument, indicating that DMA concentrations in ambient atmosphere were at maximum 20 ppq during the measurement period. Evaluation of ambient concentration is limited by apparent contamination in “zero air” from  $N_2$  flushing of inlet lines. I.e. [DMA/EA] depicted here, represents the upper limit of ambient concentration. Blue shaded areas indicate zero air measurements.

[Title Page](#)[Abstract](#)[Introduction](#)[Conclusions](#)[References](#)[Tables](#)[Figures](#)[◀](#)[▶](#)[◀](#)[▶](#)[Back](#)[Close](#)[Full Screen / Esc](#)[Printer-friendly Version](#)[Interactive Discussion](#)

## Bisulphate-cluster based atmospheric pressure chemical ionization mass spectrometer

M. Sipilä et al.



**Figure 9.** Examples of signals representing ambient measurement (blue) and zero (black) measurement. Zero gas (cryo  $N_2$ ) contains more gas phase DMA/EA and a  $C_4$ -amine (e.g. DEA) than ambient air. Only ammonia and potentially trimethyl/propyl amine (TMA/PA) signals exceed the signals from zero gas measurement. Red bars show exact masses of isotopes and expected isotopic distribution normalized to height of the main peak.

Title Page

Abstract

Introduction

Conclusions

References

Tables

Figures

◀

▶

◀

▶

Back

Close

Full Screen / Esc

Printer-friendly Version

Interactive Discussion