

# Response to Reviewers

Manuscript Title:

**Interactive comment on “Automated Enclosure and Protection System for Compact Solar-Tracking Spectrometers” by Ludwig Heinle and Jia Chen**

We would like to thank the reviewers for carefully reading the paper and giving helpful comments. Below, the reviewers’ original text is included. The answers are highlighted in blue.

## Review

1:

### General comments:

This manuscript clearly and exhaustively describes an enclosure for a mobile solar tracking spectrometer that can allow for greater measurement frequency and improved protection for the instrument against rain or other bad weather. The manuscript is very readable and describes the system effectively, but could use a small bit of English usage editing.

Thank you. To improve the English writing, we have carefully gone through the paper several times and consulted with a professional English Coach. We have corrected grammar mistakes and reduced redundancy in the paper. We will also use the English copy-editing services from Copernicus after the paper is accepted.

There are a few small points that I see as useful additions:

- 1) Size, power, and weight are not described.

Thank you for this comment. In Table 2 we have already listed the power consumption of the system components, and the total power consumption of the sensor system including the enclosure, which is about 120 W. The size of the base cabinet is 112x62x41 cm, and the weight of the enclosure including spectrometer is around 100 kg. We added Table 1 for listing the dimension and weight information.

- 2) The measurements use a laptop computer, which is not shown in the schematic diagrams. While it is clear that most operations will use remote access software to control that laptop computer, it may prove necessary to access the computer occasionally. Does physical access to the computer require opening the enclosure?

Yes, everything is inside the enclosure to be protected against harmful weather conditions. Thus, opening the enclosure will be required for accessing the components in case of malfunctions or maintenance. The computer does not necessarily have to be a laptop computer, it can be any kind of computer, running Windows, which is required for the measurement software of the instrument.

- 3) The cover rotation encoder appears to be a relative encoder, gaining absolute position information by seeking a limit switch, but the text is not fully clear on this point. Please give a little more detail.

Thank you for this note. We have modified the text in Section 2.2.4 to be more precise:

“To determine the outer cover’s position, we have developed an encoder using magnets and reed sensors that are placed inside of the notches on the covers (Figure 6). With this concept, the absolute cover position can be determined and the spectrometer is reliably protected.

Three reed sensors are glued in the notches of the inner cover, and each of the sensors has an electrical contact that closes if the sensor is exposed to a magnetic field. Nineteen neodymium magnets with a magnetic flux of 1.17 Tesla each were distributed in the notches of the outer cover. One reed sensor and a single magnet positioned in the upper notches are used to detect the closed position (absolute zero position). From then on, the motion direction is determined and the number of magnets are counted. The position can be determined with a precision of about 10 degrees. “

**Minor / typographical points:**

Page 1, line 4: The measurements are not truly continuous in time; they require direct solar viewing (clear skies, daytime). Maybe find a better wording?

Thank you. We changed the sentence to:

“It has provided ground-based measurements of column-averaged concentrations of CO<sub>2</sub>, CH<sub>4</sub>, O<sub>2</sub>, and H<sub>2</sub>O throughout this time.”

page 1, line 11: I think the authors mean "foundation" instead of "fundament"

Thank you, we have corrected this.

page 6, section 2.2.2: This is a good calculation of the azimuthal dependence of the viewing geometry, but it appears that the scanner cannot view the zenith, so at some low latitudes where the sun can get close to the zenith, the cover will block the view, causing a gap near local solar noon. Please provide a calculation of this effect.

Thanks for this comment. However, this calculation is really complex due to the following factors:

1. First, the mirror is not at the azimuthal rotational axis.
2. The azimuthal rotational axis is not concentric with the cover rotational axis
3. The elevation limits are dependent on the azimuthal position
4. The minimum exposure surface of the mirrors need to be defined

Nevertheless, we made an estimation using the 3D CAD model and added the sentence “A rough estimation based on the 3D CAD model shows that the permissible solar zenith angle range is 23(+/- 1) to 88(+/-1) degrees.” to section 2.2.2.

page 7, line 4: I think you mean "single" magnet where it says "singe"

Yes, we have corrected this typo.

Page 9, line 2: It appears that there is no seal between the circular tracker base ring and the enclosure, so it seems like ambient air (and humidity) can get into the enclosure. If the ambient T > 25C and RH is high, condensation is possible. Please describe if the system is sealed at this point or not and if so how.

There is a 2 cm spacing between the circular tracker base plate and the covers. There is no sealing, probably not even wanted, since the tracker itself provides an open path into the base cabinet (where the light beam goes). In the current construction it is most likely, that the air passes by the trackers mirrors and hit onto the cold surface of the TEC. We never experienced condensation on the TEC, which is much cooler than the Instrument. The instrument is permanently heated by itself.

Table 1 shows a laptop in the power budget, but the system drawing (Figure 2) does not show the laptop.

The Laptop is placed on top of the EM27/SUN spectrometer to ensure best accessibility. We added this information to the caption of Figure 2.

page 12, section 3.1.2: It appears that the encoder for the motion of the moving cover determines relative motion direction and "steps" as each magnet is passed. This type of controller needs a limit switch to determine absolute position, which is presumably the closed switch. Therefore, the microcontroller needs to keep track of the absolute position in software. Potentially this is not fully explained, or potentially there is some absolute position encoding with the magnet scheme that needs further explanation.

Yes, you are right. The absolute zero position is provided when the magnet activates the reed contact in the upper notch. From then on, the motion direction is determined and the number of magnets are counted.

We added this information to section 2.2.4

page 19, top: A lighter weight version of the enclosure is mentioned, but I don't think that the actual weight of the current system is discussed. It would be valuable to give the size and weight of the current enclosure system.

We included the size and weight of the enclosure system in Table 1.

page 19, line 15: missing a space in the two words "increased amount"

We have modified it, thank you.

page 19, line 20: Again, I think "fundament" should be "foundation"

We have modified it, thank you.

## **Review 2:**

The authors successfully describe in considerable detail, their design for an automated enclosure and protection system suitable for the Bruker EM27/SUN FTS. There are possibly as many solar-tracking enclosure designs as there are solar tracker designs – as these all tend to be somewhat custom in nature. In this instance, it is likely the authors' version may prove especially interesting because the EM27/SUN is proving a popular instrument, well-suited to outdoor autonomous operation, and would benefit from a successful design as described here. The paper is well-written and interesting, but would benefit from further editing for minor English grammar corrections to aid the reading flow, and to shorten the overall document. The drawings are excellent.

Thank you. To improve the English writing, we have carefully gone through the paper several times and consulted with a professional English Coach. We have corrected grammar mistakes and reduced redundancy in the paper. We will also use the English copy-editing services from Copernicus after the paper is accepted.

## **Specific comments:**

Page 1: Line 8: The words "less than" are redundant and can be deleted, as this meaning is covered by "within". Line 10: "fundament" is not in common usage, I suggest replacing with "basis". Line 15: "wellbeing" should be "well-being". Page 2: Line 1: "weight" should be "weigh".

Thank you, we have modified these points.

In the remainder of page 2, I feel that the discussion on the merits of the 125HR could be shortened or omitted. For example, the detail concerning "scanner wear" is not at all relevant to the paper, nor

to the choice between using a 125HR or EM27/SUN. It would suffice to state, in one paragraph only, the advantages of using the EM27/SUN (size, portability, rapid-deployment, nature of measurements capability etc.) and hence the need for an excellent enclosure and protection system.

Thank you for the suggestion. We have shortened the paragraph regarding 125HR, but not omitted it completely. We think that some readers would appreciate the information to understand the benefits. We would like to keep the information. People who know, can just quickly read over it, whereas others will be happy about the information.

Page 3: This page repeats or builds-upon much of what was discussed in page 2, i.e. water/weather-proof requirement and human effort etc. Consider stating these requirements concisely only once.

We have reduced the redundant information and stated the requirements only once in the introduction.

Page 6: Line 8: Are measurements not made for SZA greater than 80 deg? This might be somewhat limiting the application of the cover for other uses. The reviewer often begins measurements at 88 SZA. Please clarify if the cover can be used to the horizon (90 SZA).

We added the sentence "A rough estimation based on the 3D CAD model shows that the permissible solar zenith angle range is 23(+/-1) to 88(+/-1) degrees." to section 2.2.2.

Page 7 (and 6): No mention is made of the potential for any trapped water to freeze, jamming the cover movement. Has this occurred or likely to? If not, then consider mentioning steps taken to prevent this happening.

No, this has not been occurred and is also not likely. The enclosure is heated to 25 degrees. The warm air rises up and prevent freezing of trapped water. We have added this comment to section 4.1.

Page 8: Line 6: "block" should be "seize" or "stall".

We changed it to "stall", thank you.

In 2.3, Thermal Regulation, again there may be a bit too much detail (e.g. mention of InGaAs detector: : :). Consider reducing the discussion in the first 3 paragraphs to perhaps a single paragraph that justifies the excellent decision to use a TEC unit for thermal control. Consider too explaining that the TEC uses solid-state Peltier devices (some readers may be more familiar with this name).

We have reduced the discussion in section 2.3, and compressed the three paragraphs to one. Also we indicate TEC uses solid-state Peltier devices.

Page 9: There is good detail concerning the thermal calculations. I would like to see another sentence or two explaining why the RG-11 rain sensor was chosen – I did research this unit and it sounds an excellent choice.

We added the following paragraph:

"The sensor works as follows: an infrared LED emits light into a dome-shaped lens. The light is reflected by the lens surface and travels along its shape to the other side where it strikes a photodiode, which monitors the light intensity. When a water drop lands on the surface of the lens, less light will be detected by the photodiode because the drop allows the light to escape by refraction. RG-11 was chosen due to its dome-shaped surface. It is an improvement over a flat surface as the drops do not accumulate on the surface, which could produce a false signal after the rain stops."

Page 10: Line 7: “charged with” could be replaced with “subject to”.

Done

Concerning the UPS, it would be useful if a power outage could initiate a controlled shut down of the instrument and computer. Is this done?

No currently it is not. However, we could implement the controlled shut down of the computer in the future.

Page 11: Line 13: “a FTDI...” should be “an FTDI: : :” (F has a vowel sound “eff”).

Done

Page 14: Figure 11 caption: a coma is needed after “indicators”. Line 3: “affirmed”, more common usage would be “confirmed”. Line 12: “snow fall” should be “snowfall”.

Page 16: Figure 14 caption “snow fall” to “snowfall”.

Thank you, we have improved these language items according to your suggestions.

4.3, Thermal regulation: The reviewer has used similar TECs and had much success replacing the simple thermostat with an electronic PID controller, with parameters achieved using a self-learn function.

Thanks for the suggestion! We could think about something similar in future.

Page 19: Line 9: “facile” would be more commonly replaced by “easy” in this use.

We changed it.

Line 15: “manpower” could be made gender-neutral by using “labour” or “human effort” instead.

Done

Well done on the excellent design of your unit!

Thank you very much for your compliment and recognition!

# Automated Enclosure and Protection System for Compact Solar-Tracking Spectrometers

Ludwig Heinle<sup>1</sup> and Jia Chen<sup>1</sup>

<sup>1</sup>Environmental Sensing and Modeling, Department of Electrical and Computer Engineering, Technische Universität München, Munich, 80333, Germany

Correspondence to: Jia Chen (jia.chen@tum.de)

**Abstract.** A novel automated enclosure for protecting solar-tracking atmospheric instruments was designed, ~~built, and constructed,~~ and successfully tested under various weather conditions. A complete automated measurement system, consisting of a compact solar-tracking Fourier Transform spectrometer (*EM27/SUN*) and the enclosure, has been deployed in central Munich ~~for greenhouse gas monitoring for one year and to monitor greenhouse gases for one and half years and has~~ withstood all critical weather conditions, including rain, ~~stormstorms,~~ and snow. It has provided ~~continuous~~ ground-based measurements of column-averaged concentrations of CO<sub>2</sub>, CH<sub>4</sub>, O<sub>2</sub>, and H<sub>2</sub>O throughout this time.

The enclosure protects the instrument from harmful environmental influences while allowing ~~for~~ open path measurements in sunny weather ~~conditions. The newly developed.~~ The newly developed and patented cover, a key component of the enclosure, permits unblocked solar measurements, while reliably protecting the instrument ~~within less than 6 seconds~~. This enables ~~very~~ dynamic decisions about taking measurements, and thus increases the ~~amount~~ number of data samples.

~~The presented~~ This enclosure leads to a fully automated measurement system, which collects data whenever possible without any human interaction. ~~The functionalities of the enclosure give full control over the EM27/SUN. It provides the fundament for a long-term~~ In the long term, the enclosure will provide the foundation for a permanent greenhouse gas monitoring sensor network.

## 15 1 Introduction

Anthropogenic greenhouse gas (GHG) emissions into the atmosphere have risen to a worrying level over the last few decades. There is little doubt that this impacts the climate on earth and eventually the ~~wellbeing of mankind.~~

~~The understanding of well-being of humanity. To understand~~ greenhouse gas sources, sinks and transportation ~~requires,~~ reliable and precise atmospheric concentration measurements are required. State of the art ground-based and space-borne spectrometers are used to measure column-averaged gas concentrations by analyzing the gas ~~absorption of~~ absorptions for specific frequencies of ~~the sunlight.~~

sunlight. Ground-based solar-viewing spectrometers use the sun as a light source. Gas molecules, such as O<sub>2</sub>, CO<sub>2</sub>, and CH<sub>4</sub>, interact with the sunlight on its path through the atmosphere, resulting in absorption lines in the recorded sun spectrum.

By observing the intensity attenuation of light ~~in at~~ specific frequencies, the concentration of gas molecules within the ~~examined~~ air column can be determined.

~~The~~ Total carbon column observing network (TCCON) (Wunch et al. (2011); Toon et al. (2009)) is a global network ~~measuring that measures~~ total column concentrations. The instruments deployed in the network are *Bruker IFS 125HR* spectrometers, which provide accurate data to validate satellite observations. However, these instruments are ~~very~~-large (close to 2x3m footprint), ~~weight weigh~~ more than half a ton and are ~~extremely~~-expensive (Bruker Optic GmbH (2006)). Further, their operation is costly in terms of ~~manpower staffing~~. Therefore, many working groups operating *125HR* spectrometers use remote control or automated systems for ~~the~~-operation. A team at the *Belgian Institute for Space Aeronomy* developed *BARCOS* (Neefs et al. (2007)), which stands for "Bruker automation and remote control system". ~~Further Later~~, Geibel et al. (2010) developed an automated system ~~for the deployment of to deploy the~~ *125HR in-on* Ascension Island. The main goal of these systems is to lower the operational costs by reducing the need ~~of local and total human interactions for the for local human interaction for~~ operation. However, operation of ~~an a~~ *125HR* still requires regular skilled on-site ~~attendance maintenance~~, due to the degradation of interferometric alignment ~~given by the scanner wear on the over a~~ time scale of months (Hase (2012)).

A ~~smaller tabletop portable solar-tracking FTIR~~ spectrometer, the *EM27/SUN* (Gisi et al. (2011, 2012); Hase et al. (2016)) has ~~found lots of been employed for many~~ applications in urban greenhouse gas ~~emission studies in the recent years~~ (Hase et al. (2015); Chen ~~studies in recent years~~). It is lightweight, compact, and very robust and has ~~reached attained~~ a comparable precision to TCCON instruments (Frey et al. (2015); Hedelius et al. (2016); Chen et al. (2016)). It is easy to transport and operate, and therefore ~~a much better flexibility in site selection is permitted permits a more flexible site selection~~. While the large *IFS-125HRs* are deployed for global ~~observations, as done by TCCON, observation~~, the small *EM27/SUNs* are more often utilized for local and city source investigations (Hase et al. (2015); Chen et al. (2016); Franklin et al. (2016); Viatte et al. (2017); Chen et al. (2017) Hase et al. (2017)). Further, it has been deployed on a ship (Klappenbach et al. (2015)) and in a mobile observatory to assess volcanic emissions (Butz et al. (2017)). ~~However, up to this day a lot of human manpower~~ ~~The EM27/SUN is equipped with a solar-tracker unit, consists of motorized rotating mirrors to direct the light into the spectrometer. An external laptop is connected to the spectrometer via multiple connectors. Even though the EM27 body itself is weather resistant, the other components, e.g., the laptop, the control electronics, the solar tracker, and especially the tracker mirrors need to be protected. Hedelius et al. (2016) found degradation of the solar tracker mirrors in their spectrometer, which could have been caused by a combined action of reactive substances, sea-salt aerosols, and humidity above saturation, in which case the contaminated water droplets might be deposited on the mirrors.~~

~~Much human effort~~ is necessary to operate the instrument at ~~the a~~ measurement site. A person needs to set up the system every time before ~~starting measurements. Since the EM27/SUNs are not water proof, the measurement measuring. This~~ setup needs to be manually dismantled and stored safely, whenever the weather changes to rainy or stormy conditions. Besides wear and tear ~~at of~~ the connectors, ~~a lot of costly human effort much costly labour~~ is necessary. Even though the operators do not need to be highly trained, their permanent attention is required. Consequently, a very limited ~~willingness to measure every single hour during availability to measure during short periods of~~ good conditions reduces the amount of data ~~that is~~ collected.

~~An~~ We have developed an automated enclosure (Figure 1) that ~~allows for an easy remote operation of houses and protects~~ the measurement system ~~has been developed and is described in this paper,~~ while allowing measurements during good weather conditions. It eliminates the need to dismantle the system after ~~every~~ each measurement period, and protects against harmful weather conditions. A remote operator can ~~take care of multiple stations at the same time~~ monitor multiple stations ~~simultaneously,~~ while the setup and dismantling times can be reduced to a minimum. ~~Nevertheless, the most important function of such an enclosure is the ability to reliably protect the spectrometer and its components.~~ The easy handling combined with the small footprint size and low power consumption reduce ~~the~~ operational costs of such a measurement system to ~~nearly zero.~~ nearly zero.

~~3D Computer-Aided Design (CAD) of the enclosure including the base cabinet, the cover, the thermal electrical cooler, and the rain sensor. These hardware components will be explained in.~~

## 2 Hardware and Setup

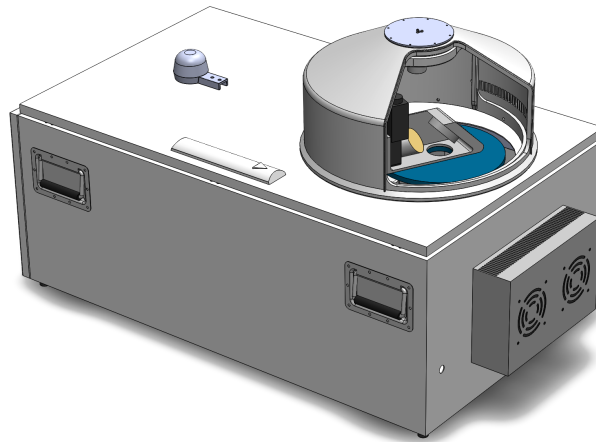
~~The EM27/SUN is a portable solar-tracking FTIR-Spectrometer. It is equipped with a solar-tracker unit, based on motorized rotating mirrors to direct the light into the spectrometer. An external laptop is connected to the spectrometer via multiple connections. All components are small and lightweight enough for easy transportation. Unfortunately, these components are not weather-proof, so that the system must be stored at a weather-protected location. During measurements the solar-tracker's first mirror needs a direct non-obstructed line of sight to the sun. Thus, the instruments need to be repositioned to an outdoor location. Thereby, transportation, setup and observation require a lot of human effort, which can be eliminated by an automated enclosure, storing and protecting the measurement system while allowing measurements during good weather conditions.~~

~~Even though the EM27 body itself is weather resistant, an enclosure is required for the protection of other components, e.g., the laptop, the control electronics, and the solar tracker, especially the tracker mirrors. Hedelius et al. (2016) found degradation of the solar tracker mirrors, which could be caused by a combined action of reactive substances, sea-salt aerosols, and humidity above local saturation, in which case, the contaminated water droplets might be deposited on the mirrors.~~

~~To build~~ To construct such an enclosure ~~there are several challenges to be solved,~~ several challenges must be faced. A safe and reliable protection against environmental influences, like dirt, thunderstorms and even hail, is needed for the measurement system. ~~For the measurement itself though,~~ though it is necessary ~~that for~~ the sun tracking mirrors of the instruments can be directly exposed to the sunlight during sunny weather conditions. ~~This leads to~~ Therefore, the prime directive for the enclosure design ~~is~~ is reliable protection and maximized amount of measurement data.

Other criteria include the best possible remote controllability ~~over~~ via the internet, the thermal stability of the system, as well as a stable and uninterrupted power supply. The ~~later~~ latter ensures error free collection of the data and prevents the system from unpredictable ~~states.~~ All in all situations. To conclude, the enclosure is ~~aimed~~ designed for automatic operation without the need ~~of human attendance or human interactions.~~ for human interaction.

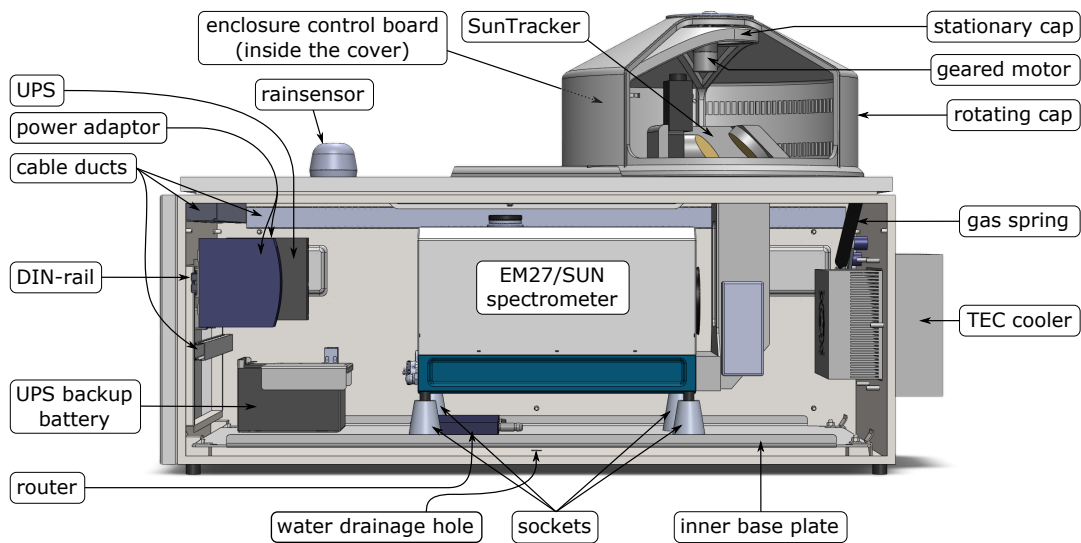




**Figure 1.** 3D Computer-Aided Design (CAD) model of the enclosure including the base cabinet, the cover, the thermal electrical cooler, and the rain sensor. These hardware components are explained in Section 2.

## 2 Hardware and Setup

An overview of the components of the automated enclosure is ~~given~~ provided in Figure 2 and its dimension and weight are given in Table 1. These components are explained in the following subsections.



**Figure 2.** Enclosure overview: components and their arrangements. The Laptop is placed on top of the EM27/SUN spectrometer to ensure a good accessibility.

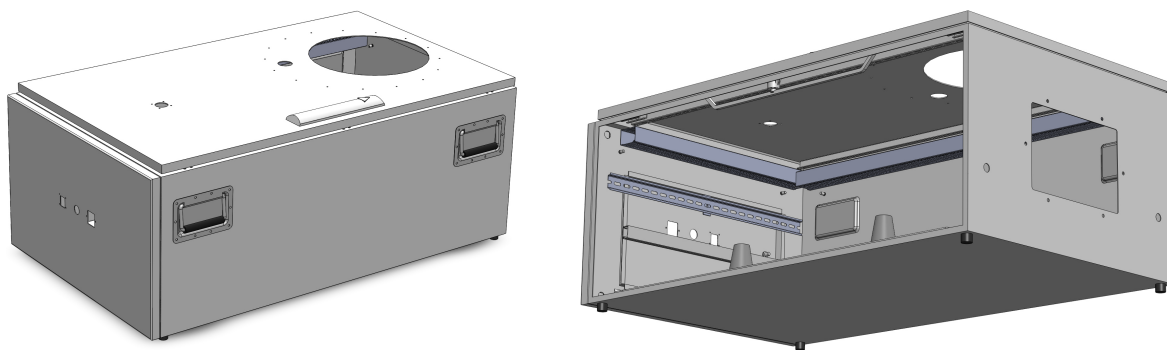
<u>Overall Dimension</u>	<u>112 x 62 x 66 cm</u>	<u>(length × width × height)</u>
<u>Base Enclosure Dimension</u>	<u>112 x 62 x 41 cm</u>	<u>(length × width × height)</u>
<u>Cover Dimensions</u>	<u>45.5 x 25 cm</u>	<u>(diameter × height)</u>
<u>Total weight (spectrometer included)</u>	<u>≈ 100 kg</u>	

**Table 1.** Dimensions and weight of the enclosure.

## 2.1 Base Cabinet

As ~~mentioned before~~previously mentioned, the *EM27/SUN* spectrometer ~~needs to be physically protected~~requires physical protections. Therefore, a stable and waterproof control cabinet is ~~turned on its back~~placed with its opening facing up and serves as ~~a base cabinet of the base cabinet for~~ the enclosure. In this orientation, the door is located on top and allows easy access to all equipment inside. Rubber feet ~~at on~~ the bottom ensure a slightly elevated stable ~~stand~~position.

The electrical components of the enclosure, such as power distribution and power supplies, are ~~well-ordered on~~attached to a DIN-rail. All ~~wirings are~~wiring is stowed in cable ducts to keep the inside ~~tidily arranged~~neatly organized, easy to access and ~~reliable in operation~~reliably operating.

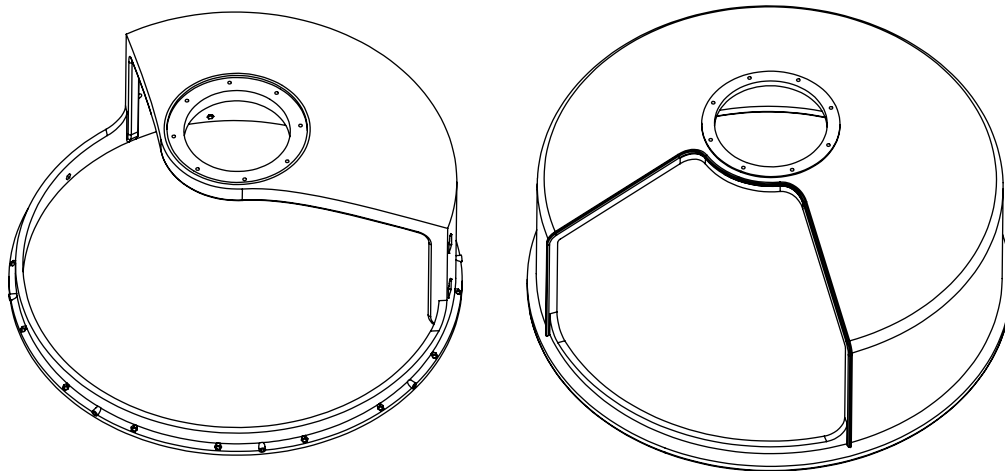


**Figure 3.** 3D-Model of the base cabinet. In the left figure the original function as a control cabinet is clearly identifiable. The handles on the side wall are mounted for easy transportation. The right image shows another perspective, with one of the side walls removed to allow a view inside the empty base cabinet.

10 The base cabinet ~~, as~~ depicted in Figure 3, is manufactured ~~in of~~ steel. Thus, it is very strong and durable. Four handles, one on each corner, allow easy transportation. The measurement system ~~easily comfortably~~ fits inside and is well protected by the base cabinet. The upper end of the solar-tracker, which rises through an opening in the base cabinet, is the only part of the measurement system ~~, that is located outside of the base cabinet. It rises through an opening in the door of the base cabinet.~~ located outside. A cover, as described in ~~the following~~ Section 2.2, is mounted over the opening, to close the enclosure and  
15 protect the instrument.

## 2.2 Cover

As mentioned before, ~~Because~~ the solar-tracker extends through the top of the ~~enclosure~~. ~~Thus it needs a separate protection base cabinet, it must be protected separately~~ against harmful environmental influences. Tests with a glass dome were ~~made performed~~ at the Karlsruhe Institute of Technology (KIT) (cf. Sha (2015)). Unfortunately, the results were not as good as expected, since it was not possible to manufacture a dome with a sufficient ~~homogeneous~~ ~~homogeneously~~ surface. The sunlight was ~~distorted differently based~~ ~~variously distorted depending~~ on the solar incident angle, which ~~disturbed the solar-tracker software~~. ~~Other than that~~ ~~affected the measurements~~. Moreover, dirt and dust on the glass surface as well as ~~possibly~~ trapped humidity inside the dome could ~~further~~ disturb the measurements.



**Figure 4.** ~~Perspective drawing~~ ~~Drawings~~ of the two ~~caps parts~~. The inner ~~cap cover~~ with its large opening is depicted on the left. The ~~cap cover~~ on the right is the outer one with a relatively small cutout.

### 2.2.1 Cover Design

10 A completely different concept is ~~chosen~~ ~~presented~~ here. A newly developed and patented cover is mounted on top of the opening, covering the solar-tracker. The cover is made of two rotationally symmetric ~~caps parts~~ with cutouts, where one ~~cap fits inside of~~ ~~fits inside~~ the other (c.f. Figure 4 and Figure 5). It protects the solar-tracker from bad weather while enabling open path measurements in dry and good weather conditions.

The outer ~~cap is pivoted~~ ~~cover rotates~~ about the vertical symmetry axis on top of the inner ~~cap cover~~. Its weight is carried by 15 eight ball bearings ~~that are mounted~~ equally distributed around the lower end of the inner ~~cap cover~~. While the inner ~~cap will be cover is~~ mounted in a stationary position on top of the ~~enclosure~~ ~~base cabinet~~, the outer one ~~can rotate~~ ~~rotates~~. The rotation is driven by a simple geared electric motor, which is mounted ~~from~~ inside in the common axis of the two ~~caps covers~~.

## 2.2.2 ~~Size of the Cover's size~~

As depicted in ~~Fig. 4~~, the inner cap has a large cutout. It enables direct sunlight to hit the sun-tracking mirrors whenever the solar zenith angle (SZA) is less than 80. The most extreme azimuthal angles will happen on the longest day of the year, which covers a range of approximately 228 for a SZA below 80 in Munich. This cover design is sufficient for all places on earth with an absolute value of the latitude of less than or equal to 48. For other places on earth closer to the poles a simple redesign of the cutouts is needed. This can be done by a simple modification of some parameters in the 3D-Model, which was made to construct the enclosure.

The opening in the outer, rotating cap (see Fig. 4) has upper and lower size limitations. The lower size ~~The dimensions of the cover is given in~~ Table 1. ~~The lower size~~ limit of the opening is given ~~outer cover's opening is determined~~ by the width of the mirrors. Since ~~the sunlight is not allowed to be blocked at~~ ~~sunlight must not be blocked during~~ sunny conditions, and the sun rays can be assumed ~~as to be~~ parallel, the opening must be at least the width of the mirrors. However, in this extreme case the cover needs to track the solar azimuth angle very precisely during the course of the day, so that it does not block the sunlight ~~off from~~ the mirrors. Furthermore, the smaller the opening is, the ~~more difficult the~~ accessibility inside the cover is ~~more difficult in case of any service demands for any maintenance~~.

The upper size limit for the opening is ~~determined by~~ the size of the inner ~~cap cover's~~ remaining wall. During bad weather conditions or darkness, the ~~two caps outer cover~~ will rotate to a closed ~~state position~~ where the inner cover wall needs to be fully ~~overlapped with~~ ~~covered by~~ the opening of the outer one. Sealing concerns and a lower demand ~~of the positioning precision push the design rules towards more overlap~~.

~~for positioning precision led the design towards greater overlap~~. Finally, an opening of 90° was considered to be a good trade off between overlapping and ~~required necessary~~ tracking accuracy for the first prototype.

~~A rough estimation based on the 3D CAD model shows that the permissible solar zenith angle range is 23(±1)° to 88(±1)°. From test results (c.f. Section 4.2) and the model, we determined the azimuthal range is from 71° to 300°. The cover was designed to be deployed in Munich, so for other places on earth, a redesign of the cutouts might be necessary. This redesign can be carried out with a simple modification of some parameters in the 3D-Model, which was made to design the enclosure.~~

## 2.2.3 Weather Proof Concept

A gap between the two ~~caps covers~~ ensures a friction-free smooth rotation of the outer ~~cap cover~~. However, rain combined with strong winds could blow water into the cover despite the overlap ~~between the inner and outer covers~~. Thus, a gasket as depicted in Figure 5 ~~is has been~~ added to the cover. It is ~~made out of~~ a window sealing strip that ~~is cut into the right height has been cut to the right thickness~~. When the cover is closed, the gasket ~~will block blocks~~ the wind and thus ~~prevent water from being blown in prevents water from entering~~. In addition, it fills the gap between the two covers and thus keeps insects from ~~going getting~~ inside. Nevertheless, the ~~weak rubber sealing will not obstruct a rubber sealing does not obstruct the~~ smooth rotation of the outer ~~cap cover~~.



**Figure 5.** The image shows the gasket gaskets that were installed to seal the gap between the two caps. ~~It prevents covers, preventing~~ water from being blown into the cover by strong winds.

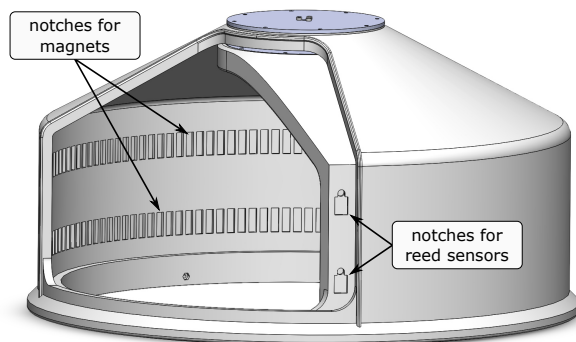
## 2.2.4 Position Determination

~~Because of the 90 opening, the outer cap~~ The outer cover needs to track the sun for undisturbed measurements. Therefore, the actual position of the outer cap cover needs to be determined.

~~The image shows the cover with the notches for magnets and reed sensors to track the outer caps orientation.~~

- 5 ~~To determine the outer cap's position~~ To this end, we have developed an encoder using magnets and reed sensors that are placed inside of the notches on the covers (~~Fig.~~ Figure 6). With this concept ~~the~~, the absolute cover position can be ~~inferred~~ directly determined and the spectrometer is reliably protected.

~~Magnetic sensors at the inner cover combined with magnets at the outer cover are used to measure the relative position of the outer cap with respect to the closed position. The sensors are reed switches with~~



**Figure 6.** The image shows the cover with notches for magnets and reed sensors to track the outer cover's orientation.

Three reed sensors are glued in the notches of the inner cover, and each of the sensors has an electrical contact that closes if the sensor is exposed to a magnetic field. 19 Nineteen neodymium magnets with a magnetic flux of 1.17 Tesla each were distributed in the notches of the outer cap. Therefore, a precision of about 5 degrees is reached for the position determination. One sensor is cover. One reed sensor and a single magnet positioned in the upper notch notches are used to detect the closed position (absolute zero position). From then on, the motion direction is determined and the number of magnets are counted. The position can be determined with a precision of about 10°.

The magnet positioned next to the cover opening activates the reed contact when the cover is closed, i. e. inner cap wall fully overlapped with the opening of the outer cap.

To determine assess the distance and direction of any movement, two more reed sensors are installed next to each other in the lower sensor notch notch of the inner cover. Whenever a magnet passes by close to the sensors, one sensor will act a little earlier than the other. This delayed operation can be used to determine the direction of movement. Multiple magnets are distributed with alternating polarity around the outer cap opposed cover opposite to the two sensors. Alternating the magnetic polarity creates a very weak field in-between-of-between two magnets as shown in Figure 7b. Compared to that this, if the magnets were placed with common polarity the same polarity, the magnetic field strength would not vary very much along significantly among the magnets as depicted in Figure 7a. Since the reed switches are sensitive to the magnetic field strength and not to the polarity, this alternating arrangement ensures a much more reliable operation of the sensors the sensors operate reliably.

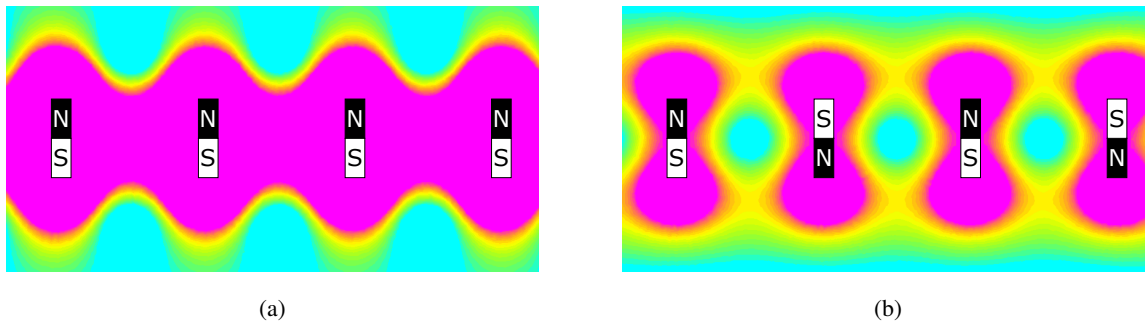


Figure 7. Comparison of the magnetic field strength when placing the magnets in common the same polarity (a) and alternating polarity (b). Cyan represents a weaker magnetic field, whereas pink represent a stronger field.

To ensure make sure that the sun path to the tracking mirrors will never be blocked, their is never blocked, the mirrors' azimuthal orientation is read directly from the mirror control. The corresponding position for the outer cover is determined and set as the target position for the cover's control unit.

### 2.3 Thermal Regulation

There are several thermal concerns regarding the EM27/SUN. It is known, that the sun trackers For instance, the sun tracker's stepping motors may block under freezing temperatures. A reason for this malfunction could be stall in freezing temperatures.

possibly due to greasing. Another point is the unknown impact of heat on the system. Inside the *EM27/SUNa*, an InGaAs-detector senses the intensity of the NIR-light coming out of the interferometer. Typical InGaAs-detectors show have a temperature-dependent transfer function (K.K. (2015); LLC (2004)). ~~This leads to the desire of,~~ which means they function best with a constant operating temperature.

5 ~~Besides these arguments, there is an even more critical point for a regulated temperature. In a situation, where the surrounding air warms up from a low temperature, for example in the morning, there is a high probability of condensation. In the case of warm air on~~ Further, condensation needs to be prevented. When warm air hits cold equipment, water vapor in the air will condensate on the cold surfaces of the equipment and ~~the tracking mirrors. This will distort the measured data or may even tracking mirrors, which can distort the data,~~ damage the electronics, ~~and can or even~~ potentially cause mirror degradations.

10 ~~During the design, multiple options were discussed. A ventilation system combined with an electric heater was thought of, which considered as a solution, but this~~ has several downsides. First of all, high humidity may be vented into the enclosure, ~~and therefore necessitating~~ an air dehumidification system may be needed, too. Furthermore, a lot number of openings would be necessary for the ventilation. ~~This offers a high,~~ increasing the risk of leaks for rainwater and small animals to enter the enclosure. ~~At last, a lot of~~ Finally, much heat may escape driven by wind blowing through ~~the~~ ventilation openings when  
15 heating is needed.

Thus, another much easier approach that even offers cooling below the outside temperature was chosen. A thermo-electric thermoelectric cooler (TEC) is installed in, using a solid-state Peltier device, has been installed at one of the walls of the base cabinet. The TEC-element is controlled by electrical current and transfers ~~pure~~ heat energy into or out of the enclosure. It does not require holes for ventilation and therefore keeps the enclosure waterproof as well as ~~locked for~~ closed to animals. Further,  
20 by ~~controlling maintaining~~ the temperature inside the enclosure ~~with a target~~ between 24°C and 25°C, condensation ~~is~~ can be avoided.

To prevent an unintended heat exchange between the inside and ~~the~~ outside of the enclosure, thermal insulation is installed. A 13 mm ~~thick~~ layer of special foam with a very low thermal conductivity, less than  $0.040 \text{ W m}^{-1} \text{ K}^{-1}$ , covers the inside of the ~~whole base cabinet. This allows~~ base cabinet, allowing a low heat transport even on high thermal gradients between the inside  
25 and the outside.

Component	max. Power
Spectrometer with solar-tracker	45 W
Laptop	30 W
Power supply and UPS	35 W
Router, Voltage converters, etc.	~ 10 W
Total	~ 120 W

**Table 2.** The table shows the expected maximum average power dissipation of all components inside the enclosure.

Because ~~there are the enclosure houses~~ many heat sources ~~inside the enclosure, cooling will be the more challenging,~~ cooling represents a greater challenge than heating. The ~~needed power~~ power necessary for cooling is calculated by the given values of the ~~component's components'~~ specifications in their data sheets. A maximum average power of about 120 W (see Table 2) ~~needs to be transferred~~ must be transferred out of the enclosure. The specification of the selected TEC ~~gives lists~~ a cooling capacity of 135 W. Thus, about 15 W of extra cooling power will be available. Equation 1 is a rough estimate of the thermal diffusion. It shows that the cooling system ~~offers enough performance to~~ can sufficiently cool the inside to about 2 K below the outside temperature.

$$\Delta T = \frac{\dot{Q}l}{\lambda A} = \frac{15\text{W} \cdot 13\text{mm}}{0.040\text{Wm}^{-1}\text{K}^{-1} \cdot 2.48\text{m}^2} \approx 1.97 \text{ K}, \quad (1)$$

where  $\dot{Q}$  stands for the thermal power to ~~transport~~ be transported along the distance  $l$ .  $A$  is the area of the thermal conduction and  $\lambda$  is the thermal conductivity of the material within the volume  $A \cdot l$ .

## 2.4 Rain Sensor

A *Hydreon RG-11* optical rain sensor is installed on top of the enclosure next to the cover. ~~If~~ When rain is detected, the integrated logic of the enclosure will automatically close the cover and send a message to the measurement system. This message may ~~be used for consecutive actions such as stopping~~ stop ongoing measurements or ~~informing~~ inform an administrator.

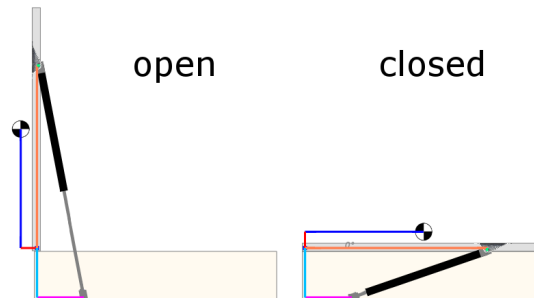
The sensor works as follows: an infrared LED emits light into a dome-shaped lens. The light is reflected by the lens surface and travels along its shape to the other side where it strikes a photodiode, which monitors the light intensity. When a water drop lands on the surface of the lens, less light will be detected by the photodiode because the drop allows the light to escape by refraction. RG-11 was chosen due to its dome-shaped surface. It is an improvement over a flat surface as the drops do not accumulate on the surface, which could produce a false signal after the rain stops.

## 2.5 Gas Spring

As described in Section 2.1, the enclosure's design is based on a control cabinet. In an upright position ~~the cabinets,~~ the cabinet's door can easily be accessed and will stay in ~~every~~ any position the user leaves it. Hence, it is not equipped with any door openers or springs. In this application ~~the cabinets,~~ the cabinet's orientation is changed, so ~~that~~ the door is now located on top. Therefore, the door's open positions are no longer stable and gravity will always push the door down. Hence, a gas spring ~~is~~ has been added to the door.

A very simplified model ~~as,~~ shown in Figure 8 ~~is used for a proper positioning and dimensioning of,~~ is used to properly position and dimension the gas spring. ~~It shows the geometries of joints as well as the door's point of gravity.~~ The gas spring is ~~calculated to not close by its own in~~ designed such that it does not close on its own at any position. Thus, an operator can never be injured by the ~~dropping door~~ door dropping. The damping of the gas spring is very strong, so that any movement is curbed to very slow speed. Additional damping ~~in at~~ the end positions ensures extra low ~~accelerations~~ acceleration, so that the cover will not be ~~charged with~~ subject to strong impacts at ~~the end~~ those positions.





**Figure 8.** Simplified model of the enclosure-base cabinet and its door to calculate the joint positions and the strength of the gas spring.

The utilized gas spring has a length of 582 mm and a maximum travel of 250 mm. Its pushing force is about 180 N, which is necessary sufficient to lift the 15 kg of the door. The maximum force at the joints is calculated to as 270 N.

## 2.6 Uninterruptible power supply

As already mentioned, the outer cap of the cover is driven by previously mentioned, an electric motor rotates the outer cover.

- 5 There is no mechanical fallback that may can close the cover in case of a power outage. Hence, an uninterruptible power supply (UPS) is mandatory. Besides that Additionally, temporary power outages will destroy measurements and may place the system in an undefined state. Therefore; therefore, the UPS is designed powerful enough to supply the whole to supply sufficient energy to the measurement system for several minutes.

## 2.7 Relays

- 10 While operating the EM27/SUN in the past, occasionally unexpected errors occurred. Some of these errors can, some of which could only be resolved by restarting the spectrometer or its camera. Thus, two relays are included so that a remote operator, or an a controlling software, can switch off the power to the spectrometer as well as disconnect its USB-Camera from the laptop.

The first relay is mounted on the DIN-rail and connects the power to the EM27/SUN. Besides resolving errors, this switch allows to power powering the instrument off during the at night and thus helps to save energy.

- 15 The second relay is located on an a USB-intermediate-plug. It was developed to allow the disconnection of the enable the solar-tracker s-USB-camera to be disconnected. In the past it has showed that, the only effective solution to recover from camera errors is to physically reconnect the camera. Therefore, the relay on the intermediate-plug simply disconnects the 5V wire of the USB-connection, which simulates the physical unplugging of the USB-connector. As long as the relay is closed, the USB-data-communication will not be affected, since the data lines of the USB-connection are left remain untouched. With  
20 the help of this little circuitry, the USB-camera can be reset by a remote operator or automatically by a software.

## 2.8 Enclosure Control Board

The control board of the enclosure handles low level access to the enclosure's hardware. It provides protective safety features, like closing the cover whenever an error happensoccurs. Furthermore, it receives commands from the laptop and operates the hardware-of-the-enclosure enclosure hardware accordingly. The control board works independently, so that to guarantee a very high level of fail safety can be guaranteed. Almost every signal on and off the board is designed for the best highest possible fault tolerance to ensure a reliable operation in every situation.

Therefore, the The control board implements the most critical safety features and serves as a tool for the laptop to operate the enclosure. The central brain on of the board is an Atmel ATmega168 microcontroller. It is a very robust The system on chip (SOC), which includes a small, 20MHz RISC<sup>1</sup> processor with integrated memory, is very robust. Besides a crystal and some capacitors, no external hardware is required, which makes it the control board very reliable. For the communication with the laptop a, an FTDI FT232RL USB to RS232 converter is placed on the board. More details on the operation of the Enclosure Control Board and the communication interface are given in Section 3.1.

## 3 Software

### 3.1 Enclosure Control Board Software

15 The enclosure control board is a central component of the enclosure. The software for the microcontroller on that board implements the enclosure's basic logic. It drives and controls, driving and controlling the electric motor of the cover and reads reading its position by evaluating the signals of the sensors in the cover. Moreover, it receives the signals of the rain sensor and UPS and communicates with the measurement system via USB. Controlling some relays, the enclosure control board can even power or unpower up or power down the spectrometer inside the enclosure. Self-monitoring and a fail-safe circuit design 20 guarantee high reliability and security. This ensures, ensuring full control and best protection of the instrument inside.

#### 3.1.1 Structure of the Software

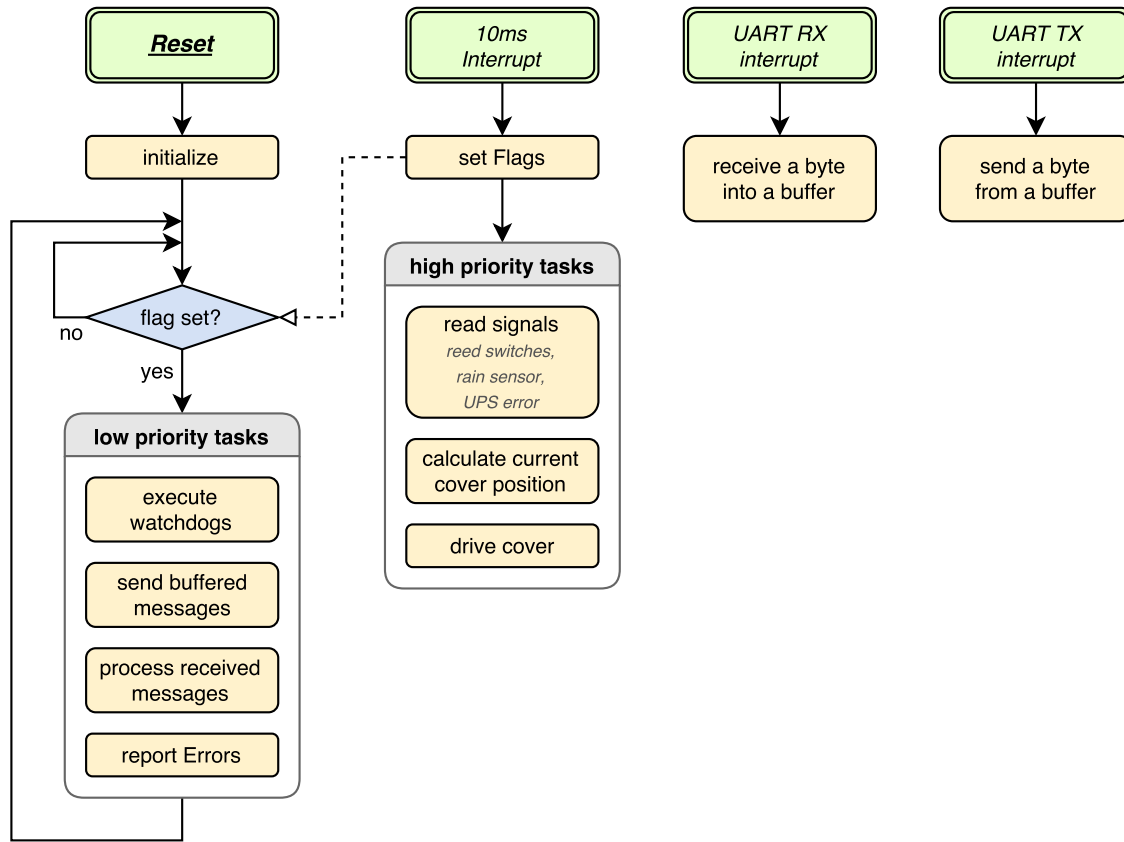
For the best possible exploitation of the To exploit the limited hardware resources as much as possible, the software is split into a set of high and low priority tasks. The most important high priority task is the control of the cover as explained in Section 3.1.2. This process will be executed inside an interrupt at a fixed period of 10ms independent of the processor's load. 25 The low priority tasks are the less time-critical time-critical, communication processes. Resetting the hardware watchdog is also classified as low priority.

A Figure 9 shows a full overview of the program flow is shown in. The reset node is the starting point of the program after every reset. After that, the processor initializes and enters its main loop, where it executes all the lower low priority tasks. An interrupt will be executed every 10ms 10 minutes, processing the higher high priority tasks.

30 Additional to that, some flags will be set to synchronize the main loop to a more or less fixed execution interval.

---

<sup>1</sup>Reduced Instruction Set Computer

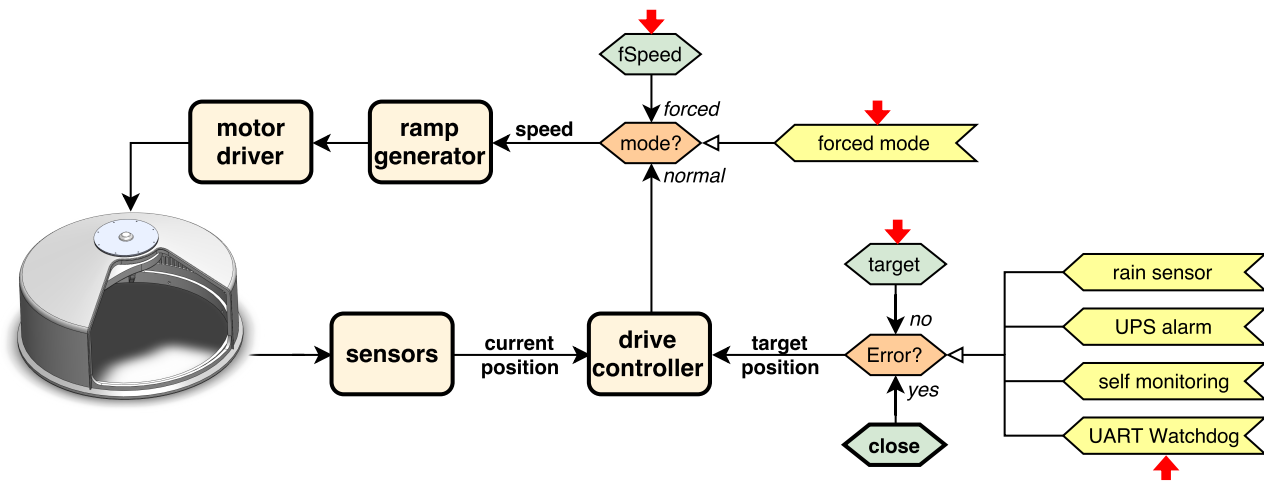


**Figure 9.** The flow chart visualizes the structure of the microcontroller’s software.

### 3.1.2 Cover Control Scheme

Figure 10 depicts the ~~control flow of the cover control~~ cover control flow. While operating in normal mode, the drive controller compares the current position to a target value. ~~The target value could~~, which can be derived from the azimuthal orientation ~~for of~~ of the tracking mirrors or the closed position. Depending on the distance between ~~both the two orientations~~, a target speed is calculated and fed into a ramp generator. ~~The ramp generator that~~ slowly accelerates or decelerates the rotation of the cover to reduce mechanical stress. Its output signal controls the motor driver, ~~which includes the power amplifier to electrically drive the motor~~. The current position of the cover is calculated from the sensor readings and fed back to the drive controller. In case of any error, the target position will be set to the closed position, as explained ~~before~~ above.

An additional forced mode ~~was is~~ is included to allow full control in case of ~~an emergency situation~~. ~~If any unexpected error happens~~ emergency. ~~If an error occurs~~, the loop can be cut open ~~over the interface via the interface~~, and a fixed value can be fed into the ramp generator. Hence, a remote operator can take full control ~~over of~~ of the cover and navigate ~~the cover it~~ into a secure position if needed.



**Figure 10.** The flow chart shows how the control-flow design of the cover is designed control flow. The red arrows indicate values that can be changed or influenced by the user via the USB-interface.

### 3.1.3 Safety Features

The microcontroller's hardware integrates includes a watchdog feature that monitors the processor's operation. A watchdog basically is is basically a timer that expects a reset signal within in its configurable period. In normal operation the watchdog timer will be reset before a timeout occurs. However, if the processor hangs gets hung at any position in the program, the watchdog timer will time out and consequently trigger a function. In case of the hardware watchdog, a full reset will be performed. Thus, full reset, guaranteeing a very high reliability of operation is guaranteed the operation.

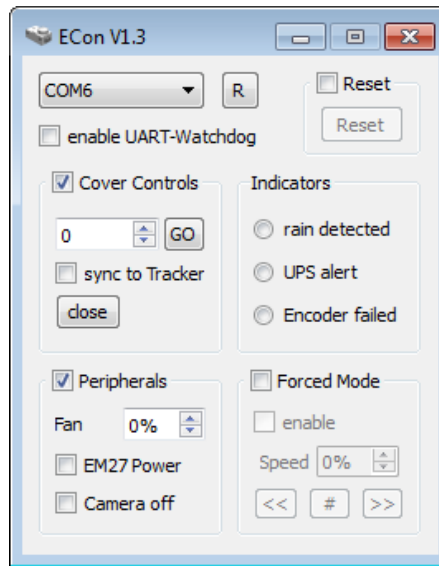
Additionally, the software provides an optional UART watchdog. When enabled, it will expect an alive message within every 5 seconds. In contrast to the hardware watchdog, which is not optional, a timeout of the UART watchdog will not trigger a system reset. Instead, an error-flag will be set and the program will consequently close the cover as can be seen in (see Figure 10).

### 3.2 Computer Software

We also developed a computer software, programmed in python, to offer a set of methods to control the enclosures functionalities with a graphical user interface (GUI). The software is programed in Python. The GUI is called *ECon*, which is derived from short for "Enclosure Control" and appears as a window on the desktop (Figure 11).

## 4 Results

After building the enclosure constructing the enclosure, its functions were tested and proved. First of all, the dryness of inside the enclosure after extreme stormy and snowy condition is affirmed confirmed. Secondly, the ability to regulate the temperature



**Figure 11.** The image shows the graphical user interface ~~which is~~ called ECon. With the given controls and indicators, nearly every ~~function of the enclosure function~~ can be controlled and observed.

inside the enclosure is examined. ~~The capability to not block~~ Next, we investigate whether it blocks the sun during the course of the day ~~is verified~~. Finally, the remote controllability and operability ~~is are~~ shown.

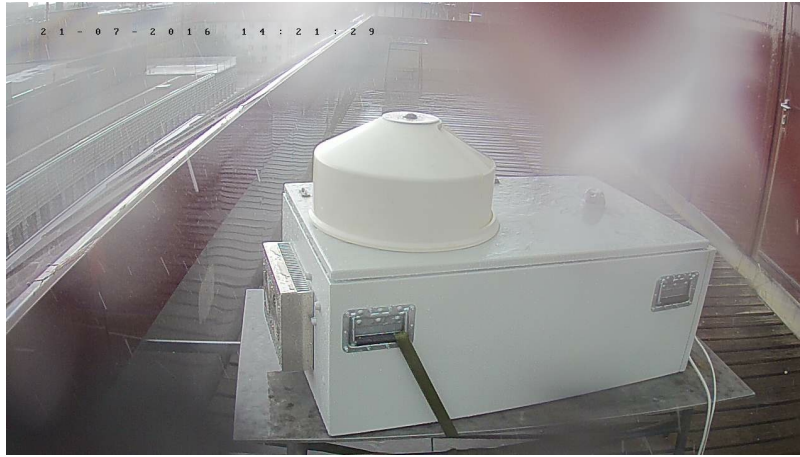
#### 4.1 Rain and Snow Test

Several extreme weather conditions acted on the enclosure. The surveillance camera, which has been installed to allow a ~~live~~ 5 view on the enclosure from remote, captured that situation remote live view of the enclosure, captured the stormy condition in Figure 12. Even after these extreme ~~rain and wind conditions the enclosure was completely dry~~ rainy and windy conditions, the enclosure remained completely dry inside and not a single drop of water penetrated it. Figure 13 shows that no water was blown into the cover. The rain sensor also reliably detected the first drop of water on its sensitive area and the cover was closed ~~within in~~ less than 6 seconds.

10 In winter 2016 ~~Munich was experiencing~~, Munich experienced a lot of snow, and the enclosure proved to be robust against ~~snow fall snowfall~~ on the cover (Figure 14). The enclosure is constantly heated and the spectrometer is able to carry out measurements whenever it is sunny, even if the ambient temperature falls below 0°C. In addition, no freezing occurred. The enclosure is heated to 25°C. The warm air rises up and prevents freezing of trapped water.

#### 4.2 Unblocked Sunlight

15 During the one year test period, the enclosure ~~has shown showed~~ no single case of blocking the sun during measurements. The test azimuthal angle ~~spans from 71.4~~ ranges from 71° to about ~~288.5296°~~, which corresponds to the range reachable



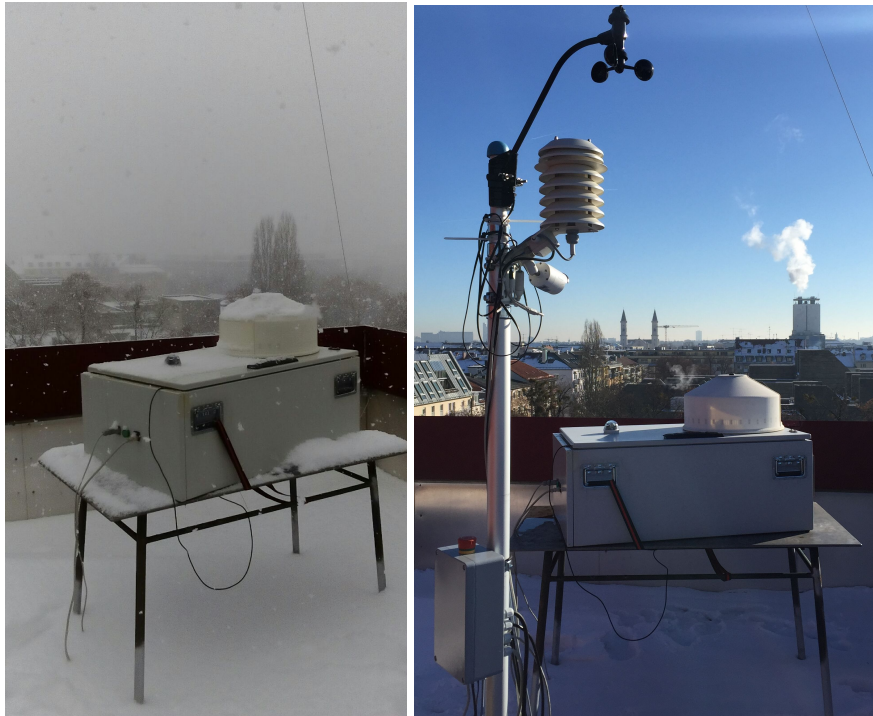
**Figure 12.** Impression of the bad weather the fully equipped enclosure was exposed to.



**Figure 13.** (a) Image of flooded stair house. The water was blown into the tilted window. (b) Image of the open enclosure after the storm. As can be seen, no water was able to penetrate the cover.

on the longest day of the year (21 June) when the solar zenith angles are below  $75^\circ$  (see Figure 15). On 29 July, the latter angle was checked in the evening. As shown in Figure 15(a), the sun was not blocked at the  $296^\circ$  (see azimuthal angle ( $88^\circ$  zenith). Afterwards, the sun disappeared behind clouds and buildings. Optical investigations revealed that the sun could remain unblocked until close to  $300^\circ$ . On the next day, the sun was unblocked at an azimuthal angle of about  $71^\circ$  in the morning ( $82^\circ$  zenith), as shown in Figure 15(b).

5

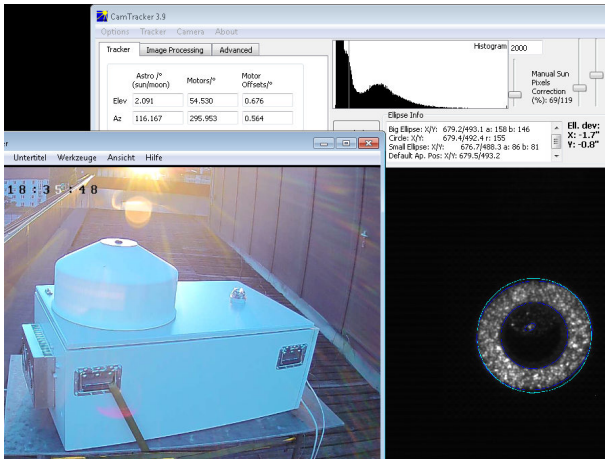


**Figure 14.** (a) During ~~2016~~-winter 2016, inches of ~~snow-fall~~ snowfall on the enclosure with the spectrometer located inside. (b) The system is taking measurements in cold winter below 0°C.

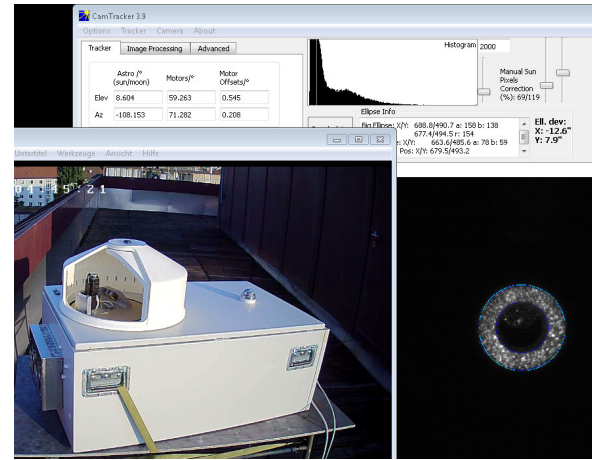
### 4.3 Thermal Regulation

The enclosure's thermal regulation was tested by logging thermal readings of the outside and inside temperatures during normal ~~operations-~~ operation (see Figure 16~~shows the logged data~~). As can be seen, the internal temperature of the enclosure does not ~~show exhibit~~ a very smooth temperature curve. ~~This is,~~ mainly because of the regulator, which follows a very simple three-point control scheme. If the temperature falls below the configured threshold of 24°C, the TEC is turned on for heating until the temperature ~~raises-rises~~ above 24.1°C. The same is valid for cooling, whereby the TEC is powered for cooling at above 25°C and disabled at 24.9°C. The regulator ~~only has the three states~~ has only three states: heating, cooling and off. There is no intermediate state, which would allow for a ~~more-smooth-smoother~~ regulation. Thanks to the temperature control, no condensation was observed on the mirrors or other components inside ~~of~~ the base cabinet.

10 ~~While-During~~ construction, the TEC was designed to pump out the heat of the measurement system. Cooling below the outside temperature were considered ~~to-be~~ a useful feature after the enclosure was ~~build-up-~~ build-in-assembled. The built-in reserves of the TEC are not large enough to cool the system more than just a few ~~degree-degrees~~ below the outside temperature ~~,as can be seen in-~~ (see Figure 16). On ~~23rd-of-23~~ July the temperature ~~can-be-was~~ controlled within the desired

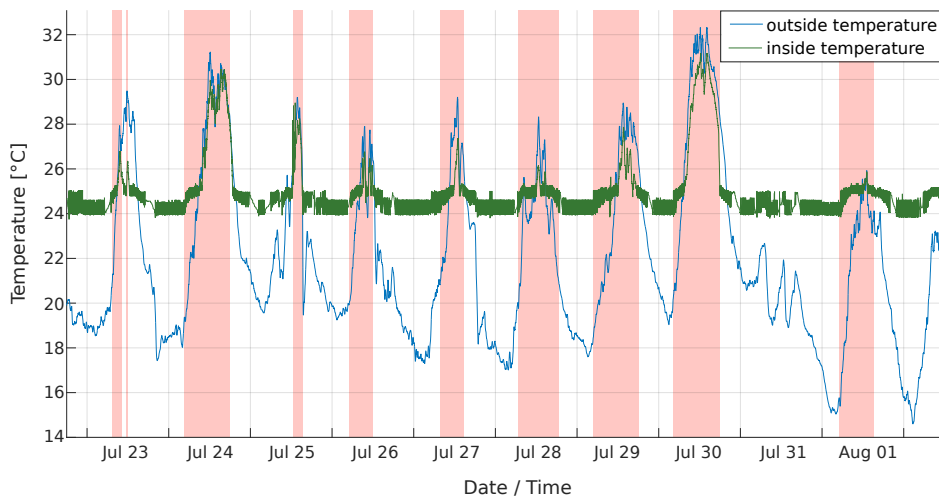


(a)



(b)

**Figure 15.** The images show screen shots of the **measurements**-laptop in the late evening (**topleft**) and early morning (**bottomright**). **In the** **The** image on the left **one can see shows** the instrument tracking the sun at an azimuthal angle of 296° on 29 July at **68:35pm35 p.m. local time**. The right image shows the **the**-tracker following the sun at about 71° azimuthal angle on 30 July at **46:45am45 a.m. local time**. As expected, in both **situations-cases** the cover did not block the sunlight.



**Figure 16.** The diagram shows the internal and external temperature of the enclosure. The red bars illustrate time periods during which the measurement system was active and therefore produced heat that **is needed-had** to be pumped out of the enclosure by the TEC.

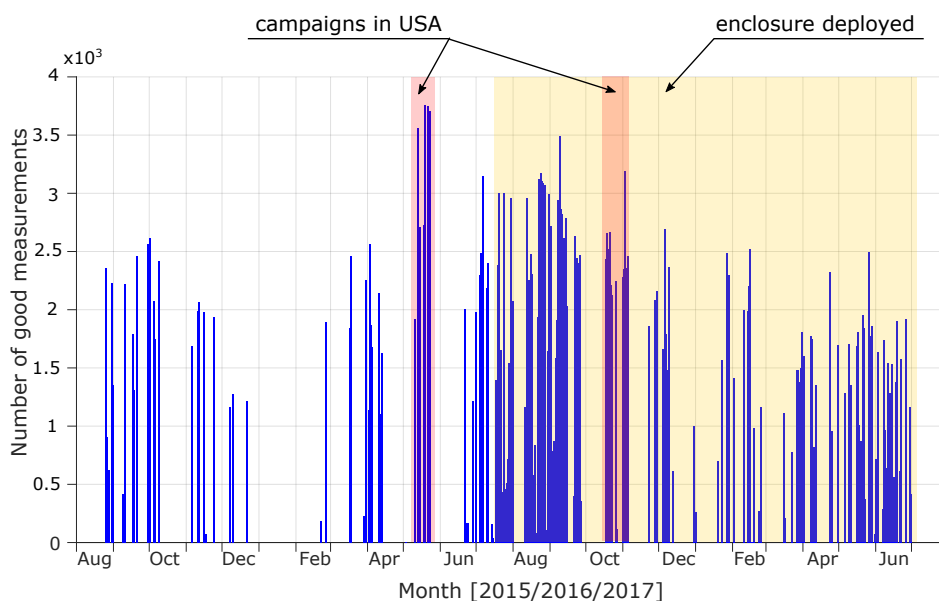
range as long as the outside temperature **is-was** lower than 27°C or the measurement system **is-was** turned off, such that less heat is generated.



## 4.4 Remote Operability

The measurement system can be fully ~~remote-operated~~operated remotely. Using a remote desktop software, any operator can log in from any computer and take control over of the system. ~~Thanks to the enclosure there is no need for physical attendance~~  
Because of the enclosure no physical attendance is required to start, stop or monitor measurements.

- 5 Figure 17 shows the ~~daily amount of collected data~~amount of data collected daily. As can be seen, the density increased clearly when the enclosure was set up for operation. ~~Nearly every day measurements were taken~~, Measurements were taken nearly every day; even small windows in the clouds were used to sample the data.



**Figure 17.** Visualization of the amount of daily sampled data with the *EM27/SUN*. The yellow region marks the time ~~duration~~ when the *EM27/SUN* ~~is was~~ deployed inside of the enclosure. During the time periods indicated by the red regions, the *EM27/SUN* was participating in the measurement campaigns in USA, Indianapolis and San Francisco Bay Area, respectively. Due to the shipping time to and back from the USA, the measurements were not taken a month before and after the campaigns.

## 5 Future Work

- In future, rain prediction information can be integrated to assist in the decision making regarding cover control. One potential  
10 approach could be to assess real time ~~on-line~~online rain radar data and meteorological forecasts to predict the upcoming weather situations.

Further improvements of the enclosure could focus on a localized thermal regulation. One could specify the most sensitive components of the measurement system and give pay particular attention to their thermal regulation. ~~This may also accomplish~~ , which could also meet the thermal demands while reducing the total energy consumption.

Another enclosure improvement could target a lightweight and portable version, which would be better suited for mobile measurements as needed in campaigns. The current enclosure was designed for stationary use and gives proof of the concept. Nevertheless, there is a high demand to use the enclosure for campaigns. This raises a whole new set of requirements such as reduced weight, size and power consumption.

## 6 Conclusion

~~An~~ We designed, engineered, assembled, and successfully tested an automated enclosure for atmospheric solar-tracking instruments, in our case *EM27/SUNs*, ~~was designed, engineered, assembled, and successfully tested~~ under extreme weather conditions. The automated solar-tracking system is located in central Munich (48.15N, 11.57E).

~~It~~ The enclosure is suited for fully autonomous operation ~~, and enables facile~~ and enables easy handling of the measurement system. When potentially ~~harmful-poor~~ weather conditions arise, the system can be shut down and protected within seconds. In case of ~~unexpected-sudden~~ rain, the enclosure reliably protects the measurement system by closing its cover. In this manner, the measurement system is sheltered from heavy storms, rainfalls, and snowfalls without ~~the need for~~ need of any physical human interaction.

Remote access can be ~~gained~~ obtained by any smartphone or computer. Thus, the system can be observed and controlled ~~within a few seconds~~ from anywhere in the world. This considerably lowers the inhibition level to start measurements ~~immensely~~, resulting in a ~~significantly increased amount of collected data~~ significant increase in the amount of data collected. Furthermore, the automated enclosure reduces the need for costly ~~manpower~~. ~~This leads to a much higher efficiency of the measurement system. The increased amount of collected data will finally optimize the~~ human effort and optimizes the chance to sample good data, even during periods of instable weather conditions. ~~This will~~ Accordingly, the measurement system has a much higher efficiency, which should increase the significance of any scientific outcome ~~that is~~ derived from these data.

~~All in all~~ In sum, the enclosure provides the main functionality for a complete automation of the measurement system, ~~it~~ guarantees maximization of ~~collected data amount~~ the amount of data collected while minimizing the operational risks and costs, ~~and thus provides a fundament for a~~ thus providing a foundation for long-term GHG monitoring sensor network.

Acknowledgments. We gratefully thank Gerold Wunsch for helping with the cover concept development. We also acknowledge our Bruker colleagues Peter Maas, Gregor Surawicz for technical support. Further, we thank Florian Dietrich, Frank Hase, Bruce Daube, Steven C. Wofsy, Andreas Meichelböck, Johannes C. Paetzold, Duc Hai Nguyen, and Patrick Aigner for fruitful discussions and Stephen Starck from the TUM language center for the helpful English editing.

Jia Chen and Ludwig Heine are supported by Technische Universität München - Institute for Advanced Study, funded by the German Excellence Initiative and the European Union Seventh Framework Programme under grant agreement n° 291763.

## References

- Bruker Optic GmbH: IFS 125 User Manual, [http://spec.jpl.nasa.gov/ftp/pub/outgoing/IFS125HR\\_manual.pdf](http://spec.jpl.nasa.gov/ftp/pub/outgoing/IFS125HR_manual.pdf), 2006.
- Butz, A., Dinger, A. S., Bobrowski, N., Kostinek, J., Fieber, L., Fischerkeller, C., Giuffrida, G. B., Hase, F., Klappenbach, F., Kuhn, J., Lübecke, P., Tirpitz, L., and Tu, Q.: Remote sensing of volcanic CO<sub>2</sub>, HF, HCl, SO<sub>2</sub>, and BrO in the downwind plume of Mt. Etna, *Atmospheric Measurement Techniques*, 10, 1–14, doi:10.5194/amt-10-1-2017, <https://www.atmos-meas-tech.net/10/1/2017/>, 2017.
- 5 Chen, J., Viatte, C., Hedelius, J. K., Jones, T., Franklin, J. E., Parker, H., Gottlieb, E. W., Wennberg, P. O., Dubey, M. K., and Wofsy, S. C.: Differential Column Measurements Using Compact Solar-Tracking Spectrometers, *Atmospheric Chemistry and Physics*, doi:10.5194/acp-2015-1058, 2016.
- Chen, J., Nguyen, H., Toja-Silva, F., Heinle, L., Hase, F., and Butz, A.: Power Plant Emission Monitoring in Munich Using Differential  
10 Column Measurements, in: EGU General Assembly Conference Abstracts, vol. 19 of *EGU General Assembly Conference Abstracts*, p. 16423, 2017.
- Franklin, J. E., Jones, T., Floerchinger, C. R., Hajny, K. D., Parker, H. A., Heinle, L., Paetzold, J., Lavoie, T. N., Wofsy, S. C., Chen, J., Shepson, P. B., Mielke, L. H., Richardson, S., Davis, K. J., Gottlieb, E., Budney, J., Dubey, M. K., and Hase, F.: Multi-scale Top-down Closure of CH<sub>4</sub> & CO<sub>2</sub> Sources in Indianapolis using Distributed Column and in situ Airborne and Tower Measurements, *AGU Fall  
15 Meeting Abstracts*, 2016.
- Frey, M., Hase, F., Blumenstock, T., Groß, J., Kiel, M., Mengistu Tsidu, G., Schäfer, K., Sha, M., and Orphal, J.: Calibration and instrumental line shape characterization of a set of portable FTIR spectrometers for detecting greenhouse gas emissions, *Atmospheric Measurement Techniques*, 8, 3047–3057, 2015.
- Geibel, M. C., Gerbig, C., and Feist, D. G.: A new fully automated FTIR system for total column measurements of greenhouse gases,  
20 *Atmospheric Measurement Techniques*, 3, 1363–1375, doi:10.5194/amt-3-1363-2010, <https://www.atmos-meas-tech.net/3/1363/2010/>, 2010.
- Gisi, M., Hase, F., Dohe, S., and Blumenstock, T.: Camtracker: a new camera controlled high precision solar tracker system for FTIR-spectrometers, *Atmospheric Measurement Techniques*, 4, 47–54, doi:10.5194/amt-4-47-2011, 2011.
- Gisi, M., Hase, F., Dohe, S., Blumenstock, T., Simon, A., and Keens, A.: XCO<sub>2</sub>-measurements with a tabletop FTS using solar absorption  
25 spectroscopy, *Atmospheric Measurement Techniques*, 5, 2969–2980, 2012.
- Hase, F.: Improved instrumental line shape monitoring for the ground-based, high-resolution FTIR spectrometers of the Network for the Detection of Atmospheric Composition Change, *Atmospheric Measurement Techniques*, 5, 603–610, doi:10.5194/amt-5-603-2012, <https://www.atmos-meas-tech.net/5/603/2012/>, 2012.
- Hase, F., Frey, M., Blumenstock, T., Groß, J., Kiel, M., Kohlhepp, R., Mengistu Tsidu, G., Schäfer, K., Sha, M., and Orphal, J.: Application  
30 of portable FTIR spectrometers for detecting greenhouse gas emissions of the major city Berlin, *Atmospheric Measurement Techniques*, 8, 3059–3068, 2015.
- Hase, F., Frey, M., Kiel, M., Blumenstock, T., Harig, R., Keens, A., and Orphal, J.: Addition of a channel for XCO observations to a portable FTIR spectrometer for greenhouse gas measurements, *Atmospheric Measurement Techniques*, 9, 2303–2313, doi:10.5194/amt-9-2303-2016, <https://www.atmos-meas-tech.net/9/2303/2016/>, 2016.
- 35 Hedelius, J. K., Viatte, C., Wunch, D., C., R., Toon, G. C., Chen, J., Jones, T., Wofsy, S. C., Franklin, J. E., Parker, H., Dubey, M., and Wennberg, P. O.: Assessment of errors and biases in X<sub>gas</sub> retrieved from a low resolution spectrometer (EM27/SUN), submitted to *Atmospheric Measurement Techniques*, amt-2016-39, initial submission, 2016.

- K.K., H. P.: InGaAs Photodiodes, [https://www.hamamatsu.com/resources/pdf/ssd/ingaas\\_kird0005e.pdf](https://www.hamamatsu.com/resources/pdf/ssd/ingaas_kird0005e.pdf), 2015.
- Klappenbach, F., Bertleff, M., Kostinek, J., Hase, F., Blumenstock, T., Agusti-Panareda, A., Razinger, M., and Butz, A.: Accurate mobile remote sensing of XCO<sub>2</sub> and XCH<sub>4</sub> latitudinal transects from aboard a research vessel, *Atmospheric Measurement Techniques*, 8, 5023–5038, 2015.
- 5 LLC, T. J. T.: Indium Gallium Arsenide Detectors, [http://www.judsontechnologies.com/files/pdf/InGaAs\\_shortform\\_DEC2004\\_rev2.pdf](http://www.judsontechnologies.com/files/pdf/InGaAs_shortform_DEC2004_rev2.pdf), 2004.
- Neefs, E., De Mazière, M., Scolas, F., Hermans, C., and Hawat, T.: BARCOS, an automation and remote control system for atmospheric observations with a Bruker interferometer, *Review of Scientific Instruments*, 78, 035109, doi:<http://dx.doi.org/10.1063/1.2437144>, <http://scitation.aip.org/content/aip/journal/rsi/78/3/10.1063/1.2437144>, 2007.
- 10 Sha, Dr. M. K.: Glass dome selection as a cover for protecting remote sensing instruments performing atmospheric measurements of trace gases, Technical notes, Karlsruhe, Karlsruher Institut für Technologie (KIT), 2015.
- [Toja-Silva, F., Chen, J., Hachinger, S., and Hase, F.: {CFD} simulation of {CO2} dispersion from urban thermal power plant: Analysis of turbulent Schmidt number and comparison with Gaussian plume model and measurements, \*Journal of Wind Engineering and Industrial Aerodynamics\*, 169, 177 – 193, doi:<https://doi.org/10.1016/j.jweia.2017.07.015>, <http://www.sciencedirect.com/science/article/pii/S0167610517302258>, 2017.](https://doi.org/10.1016/j.jweia.2017.07.015)
- 15 Toon, G., Blavier, J.-F., Washenfelder, R., Wunch, D., Keppel-Aleks, G., Wennberg, P., Connor, B., Sherlock, V., Griffith, D., Deutscher, N., et al.: Total column carbon observing network (TCCON), in: *Fourier Transform Spectroscopy*, p. JMA3, Optical Society of America, 2009.
- Viatte, C., Lauvaux, T., Hedelius, J. K., Parker, H., Chen, J., Jones, T., Franklin, J. E., Deng, A. J., Gaudet, B., Verhulst, K., Duren, R., Wunch, 20 D., Roehl, C., Dubey, M. K., Wofsy, S., and Wennberg, P. O.: Methane emissions from dairies in the Los Angeles Basin, *Atmospheric Chemistry and Physics*, 17, 7509–7528, doi:10.5194/acp-17-7509-2017, <https://www.atmos-chem-phys.net/17/7509/2017/>, 2017.
- Wunch, D., Toon, G. C., Blavier, J. F., Washenfelder, R. A., Notholt, J., Connor, B. J., Griffith, D. W., Sherlock, V., and Wennberg, P. O.: The total carbon column observing network, *Philos Trans A Math Phys Eng Sci*, 369, 2087–112, 2011.