

November 26th, 2018

Dear Associate Editor,

Please, find attached the replies to the referees' comments as well as the new version of the manuscript where all the changes respect to the version published in AMT-Discussion have been marked-up. We appreciate the additional time you have given us (through successive postponements) to address the comments from the referees. They have required substantial changes and new information and results to be incorporated in the manuscript. Unfortunately, there has not been time to get the new version of the manuscript English edited by a native speaker as suggested. We apologize for it. If you consider necessary English editing to be performed, I suggest it could be done in the next iteration in the manuscript.

Yours sincerely,

Angel J. Gomez-Pelaez and Emilio Cuevas

“Atmospheric CO₂, CH₄, and CO with CRDS technique at the Izaña Global GAW station: instrumental tests, developments and first measurement results” by Angel J. Gomez-Pelaez et al. (<https://www.atmos-meas-tech-discuss.net/amt-2017-375/>)

Author’s Replies to the Comments of Referee #1

This work describes the GHG measurement system at Izaña Observatory (IZO). Several novel measurement methods or improvements to standard methods are described, including a new correction to CO₂ in Picarro analyzers that is caused by inhomogeneous mixing in the measurement cell of the analyzer that is affected by flow rate. **It should be published after corrections outlined below.**

We acknowledge the constructive and extensive comments of the referee.

R1.M1) One major comment that should be addressed is the determination of the CO₂ correction for inlet pressure variation should be tested more. Details and recommendations are below.

We have performed additional tests to determine this correction. They confirm our previous findings. In the revised version of the manuscript we are going to detail these new tests and expand the information about the previous tests.

R1.M2) A second is that the authors use a few more complex fits and equations for corrections than reported previously in the literature for these same instruments, and there is little justification or evaluation of the improvement that these complex corrections make on the data, or reduction in error/uncertainty (e.g. quadratic fit to the CO₂, and water vapour corrections).

In the new version of the manuscript we justify better and more these points mentioned. We agree with your comment that for CO₂ we are using a more complex fitting in mole fraction than it is usually done in the literature (quadratic instead of linear), but this is not the case for the water vapour corrections. Concerning this H₂O correction, for CO₂ and CH₄ we use equations of the same type than in the literature, whereas for CO we use almost the same equation than in the literature, indeed our equation is a bit simpler since one of the polynomials is cubic instead of quartic (see Eq. [5] of Chen et al., 2013, AMT amt-6-1031-2013; and section 2.2.5 of Karion et al. , 2013, AMT amt-6-511-2013). The novelties we present in the H₂O correction for CO are in the way the processing is done. We are going to explain this more in the new version of the manuscript.

Major & Minor comments:

R1.m1) Acronyms: Some are introduced without definition in the abstract (CO₂, WMO); Others esp. in the introduction are defined backwards from the usual convention, i.e. the acronym comes first with the expansion in parentheses. But not consistently. And some are introduced (WMO) prior to definition. The authors should carefully go through the text and fix these.

Thanks. This is fixed in the new version of the manuscript.

R1.m2) L29: awkward (requirements are higher as higher the lifetime...). Requirements are more stringent for gases with a longer lifetime perhaps?

Done as suggested.

R1.m3) P2, L4: American billion?

"American" removed. Now just "billion" (one thousand million). In the past, in British English one billion was one million million (this continues being the case in some languages).

R1.m4) P2, L4, ppm should be defined here as micromoles per mole of dry air, or dry mole fraction. (and similar for ppb).

We have added these suggestions.

R1.m5) P2 L8 awkward: "therefore, the required frequency... is much lower".

Done.

R1.m6) P2 L30 Tertiary should not be capitalized I don't think.

Agreed.

R1.m7) P2 L32 until now

Done.

R1.m8) P3 L12 "being" should be ", rejecting the first hour as stabilization time."

Done.

R1.m9) Table 1 caption should say "for two averaging times". Some note should be made explaining the negative water vapour values here.

Done. Note that the precision for H₂O measurements indicated by the manufacturer of the CRDS is: <200 ppm for 5-second averages, and < 50 ppm for 5-minute averages. Therefore, it is reasonable obtaining negative values (-2.8 ppm) for H₂O when measuring dry air, since, taking into account the precision of the instrument, these values are completely compatible with 0.0 ppm. A note clarifying this point is added.

R1.m10) Table 2 - wouldn't this be a more appropriate place to report the average H₂O? It would be good to know if the water vapour had completely left the stream by the time these SD's were taken. Some explanation of the higher SD's over these 10 minutes compared to the Table 1 results should be made - perhaps the cylinder is still "stabilizing", but then did the authors see a trend in the measurement over the 10 minutes? Was any such trend or noise caused by water vapour still drying out?

We agree with your first comment. We are going to include in this table the average H₂O. What any of the SD of tables 1 and 2 means is the SD of the sample of 1-minute, 10-minute or 60-minute means obtained along the full duration of the experiment (we clarify it better in the new version of the manuscript). We re-write your second comment as: the SD's (associated to 10-minute means) in table 2 are larger than the SD's in table 1 associated with 1-minute means. Apparently, this might seem contradictory since we expect a decrease in the random noise when increasing the averaging period. However, table 1 considers a 24-hour-long test, whereas table 2 considers a 72-hour-long test, and because of this, the SD of the set of 10-minute means is larger, since it includes the drift in the response of the instrument. Indeed, the purpose of this second test is monitoring the instrument drift along 3 days. We also include a note in the new version to point out this fact.

R1.m11) P4 L4: How was the ambient pressure test conducted? This paragraph should have more detail (pressure chamber?). I agree the effect of ambient pressure is small -you could note that this analyzer is not meant for use on aircraft where large pressure changes might

occur. But I still wonder if this effect on the measurements is transient or dependent only on the absolute ambient pressure. Yver Kwok et al state that they find no ambient pressure dependence on CO₂ and CH₄.

In the new version of the manuscript we are including more details about this test. We will also add the note you mention. Thanks. We have not used a pressure chamber for the test, but simply taking into account the atmospheric pressure changes during the 72-hour test, in a similar fashion than ICOS-ATC (ICOS Atmospheric Thematic Centre for Atmosphere) did. Therefore, the test provides an upper-limit for the ambient pressure sensitivity, since there might be instrumental drift not attributable to atmospheric pressure changes. According to our knowledge, Yver Kwok et al. (2015) proceed in the same way than us (not using a pressure chamber). Our main purpose with this test was to discard we had one of the CRDS units whose CO measurements are affected by natural ambient pressure changes. We do think the sensitivities we have obtained for CO₂ and CH₄ are within what Yver Kwok calls not significant (we obtain 0.0038 ppm/hPa for CO₂ and 0.047 ppb/hPa for CH₄), as it happens for CO (0.04 ppb/hPa)

R1.m12) P4 L10: these pressures should be given in millibar or SI units - presumably this is gauge pressure, psig. Absolute pressure would be better, perhaps stating the regulator gauge pressure in parentheses. Was the effect only noted for these two pressures, or was there more testing done at intermediate pressures? Was it repeatable, or are these numbers given only for the single test between two pressures? (this is a question I had later, on how the fit was made to the outlet valve - was the fit based only on two points, and was it evaluated for a repeated test?).

We agree, hPa are going to be used as units. Yes, this was gauge pressure. We are going to use absolute pressure following the referee's advice. Since the effect is quite small, these two "extreme" pressures were used to maximize the signal to noise ratio. The test was repeated two different days with the same results. When accounting for this effect the fitting to the CO₂ response function improved significantly in the first calibrations, when we were not so skilled adjusting precisely the CRDS inlet pressure corresponding to each gas cylinder. Therefore, intermediate pressures had been tested indirectly. The same considerations apply for the outlet valve.

We have performed additional tests to determine this correction, including intermediate pressure points and even a larger pressure range. They confirm our previous findings. In the revised version of the manuscript we are going to detail these new tests and expand the information about the previous tests.

R1.m13) p4 L23: "during that first calibration" - what calibration? perhaps "During the calibration described above,"

Done.

R1.m14) P4 L27, awkward phrasing "to the computation". Perhaps just "Pre-processing refers to the computation of raw data 3-second means... as well as the computation of some derived variables". (what variables?). Also "no" should read "not".

Done. Thanks.

R1.m15) P5 L3-10. It is not clear why certain variables are associated with certain species codes. I thought that the species code had to do with which laser was making the

measurement (or the frequency range it was covering). One sentence explaining this perhaps would be useful to the reader. It might not be useful to mention the CO₂_dry and CH₄_dry variables, as they confuse things and they are not used in this work at all - they get updated after the h₂o_reported scan. I find the explanation of each variable useful however. I think CO₂_dry is erroneously mentioned twice: once with species=2 and once when species=3.

Yes, you are right, the species code indicates in which spectral range the measurements are performed. There are 4 spectral ranges and 3 lasers. Two nearby spectral ranges are scanned with the same laser. We are going to add a sentence explaining it in the revised version of the manuscript. CO₂_dry and CH₄_dry are mentioned by completeness and for helping readers to “disentangling” the CRDS raw files (you are right, they are updated once the main spectral line of h₂o is measured). The time sequence in which the species are scanned is going also to be indicated: 1, 2, 4 and 3. CO₂_dry appears in two species: 2 and 3. This is not a mistake. The manufacturer might have decided to obtain an updated CO₂_dry value using the H₂O of the previous measurement cycle without waiting to the end of the current measurement cycle.

R1.m16) Why are both the MPV and SV fields used - should mention why these are monitored - presumably your gas handling uses both solenoid and MPV valves controlled by the Picarro software?

You are right, our gas handling system uses both solenoid and MPV valves controlled by the Picarro software. We are going to add a sentence mentioning it.

R1.m17) P5 L19, I believe the flow in the orifice itself is sonic, and is supersonic immediately downstream, depending on the ratio of upstream to cavity pressure. Also pressure units should be in mb or other SI, with torr in parentheses.

You are right, the flow has Mach number one just at the orifice, and larger than one just downstream of orifice. We are going to indicate it in the new version of the manuscript. As it is mentioned in Appendix A, within the inlet pressure range recommended by the manufacturer, the flow is always supersonic just after the orifice. We are going to use hPa units in the new version of the manuscript, as recommended by the referee.

R1.m18) P5 L20 was this linear relationship between OV and inlet pressure confirmed in your tests? This should be investigated and shown, not just assumed, as the inlet pressure/flow correction is using the OV variable as a direct proxy for flow rate essentially.

This linear relationship between OV and inlet pressure has been confirmed in numerous additional tests we have performed (using several pressures in each test). We are going to show this in the new version of the manuscript.

R1.m19) P5 Eq 1 - it would be good to see some more information on this fit. Was it really based only on the two different pressures investigated in the test? Could a fit to more pressures be performed? how good or bad is the fit - what are the residuals from the test itself? This is one of the main findings of this work, and has not been reported before, as the authors point out, so more work is needed to show the reader how the correction was determined, how it performs, and its consistency over time and after a reboot. The fit should be tested by performing a test again and checking for consistency and for errors after the fit was applied, esp. its reliance on the OV variable.

Please, refer to our replies to comments R1.m12) and R1.m18).

I do believe that because the inlet orifice is not a physical orifice but rather a proportional valve fixed at a certain opening, after the analyzer has a power cycle (reboot), it may not come back to the same spot exactly (the valve is not so precise, so given the same voltage might open to a different diameter slightly), and following that, the OV may not be in the same spot, i.e. for the same inlet pressure as prior to the power cycle, the OV value may differ. I think that this would render equation 1 incorrect and would need to be re-calculated. This should be checked and determined. It may be necessary to install a pressure sensor upstream of the CRDS instrument and perform a linear fit on that rather than relying on the OV. This may not be true if there is a physical critical orifice upstream whose aperture never changes. The aircraft analyzers do have a physical critical orifice so that they can maintain a constant given flow rate, even after the instrument is rebooted.

According to the information provided to me by the manufacturer (Rella, private communication), "there is both a proportional valve and a physical orifice in the inlet system of the G2401. The proportional valve is opened slowly at startup to ensure that the flow smoothly changes, but after this startup procedure, the valve is set to full open, and the flow is set by the orifice".

Note also that if Eq. (1) is expanded, only the slope term in OV is kept fixed, since the independent term is, in practice, combined with the independent term of Eq. (6), and the latter equation is updated each time a mole fraction calibration is performed. Therefore, it automatically takes into account hypothetical drifts in the independent term of Eq. (1). The impact in the slope (in OV) by hypothetical drifts in the outlet valve controller is quite limited as it is going to be shown in the revised version of the manuscript.

The main advantage of the aircraft analysers is that they have the critical orifice at the outlet of the cavity instead of at the inlet. Since at critical orifices the (supersonic) flow rate is determined by the pressure and temperature at its inlet, for aircraft analysers the flow rate is constant no matter the huge changes in the pressure at the CRDS inlet that takes place during a flight.

R1.m20) p6 L22: perhaps rephrase to : "provided results that satisfied our accuracy requirements".

Done. Thanks.

R1.m21) P6 L24: This helps avoid...

Done.

R1.m22) P6 L25: that might propagate to the interior of the cylinders...

Done.

R1.m23) P7 L6: What reason is given for going to a quadratic fit for CO₂ here? In other literature (including Yver Kwok et al) a linear fit is generally used. Perhaps the authors can justify the use of a more complex curve for this instrument. It is useful to note that the residuals of a calibration should be compared to the assigned 1-sigma uncertainty of the gas standard relative to the scale. For NOAA tanks, this is something close to 0.02-0.03 ppm (as cited in Andrews et al., but could be checked for specific cylinders perhaps?). You wouldn't expect the residuals to be better than that.

No reason was provided in this part of the manuscript, but in the last paragraph of Sect. 2. In the new version of the manuscript we are going to justify also before Eq. (6) the reasons for using a quadratic fit.

R1.m24) p7 L6, L9: I would suggest replacing "real dry mole fraction" by "the dry mole fraction assigned by the CCL on the WMO scale".

Done. Also, after Eq. (5).

R1.m25) p7, L16 "high-accuracy"

Done. Since "accuracy" is the noun and "accurate" is the adjective, we preferred to use "high-accurate".

R1.m26) p7, L17 should read: the calibration fits are generally performed using a limited range...

Done. Thanks.

R1.m27) p7 Is the virtual tank concentration its assigned value (x-axis) or measured value (y-axis)? Presumably, following the convention of equations 4-6, it is the x-axis, assigned value that is constant at 400 ppm and the raw response for that value is what is calculated using the equations. Perhaps just state this in the text when you mention the tank values.

The virtual tank concentration is the assigned value (X-axis). Agreed, we are going to state what you mentioned in the text of the revised manuscript.

R1.m28) p8-9: explain that the drift you are referring to is drift in the P, T sensors that then causes the cavity to be controlled at a slightly drifting temperature. P9, L1: Was this supposed to read .152 degrees C / year rather than Torr?

Agreed, in the new version of the manuscript we are going to state explicitly what you mentioned. No, it is 0.152 degrees C/Torr since the first step is to obtain the slope in the p-T space using Eq. (8), and then it is possible to obtain the dp/dt value using Eq. (9). We are going to state it more clearly in the new version and provide also the dT/dt value.

R1.m29) Fig 2: is the slope of the red line here equal to the left hand side of equation 8?

When multiplying that slope by 400/1850, we obtain the left-hand side of Eq. (8) (see the last paragraph of page 7 in the Discussion paper). We are going to state it more explicitly in the new version of the manuscript.

R1.m30) Eqn 8 & 9: A little more information on this would be good. Does this analysis assume that Temperature drift is a linear function of pressure drift? I guess if they are both linearly drifting with time, this makes sense.

Equations (8) and (9) are general relationships between partial derivatives that do not rely on any assumption. They can be directly applied to characterize the response drifts in our paper since Figs. 1 and 2 have shown that the drifts are linear. We are going to state it explicitly in the new version of the manuscript. Since the left-hand-side of Eq. (8) is constant (linear relationship shown in Fig. (2)), the slope dT/dp is constant (due to Eq. (8)). Since the derivative in time of the fractional change of CH₄ is constant (linear relationship shown in Fig. 1), the slope dp/dt is constant (due to Eq. (9)), and therefore p drifts linearly in time. Finally, since dT/dp and dp/dt are constant, dT/dt is also constant, and therefore T drifts linearly in time.

What is the slope? (Yver Kwok report a mean of 2.4). Perhaps a plot of the fractional change rather than the plot in Figure 2 would be more applicable to explain equations 8 & 9 (similar to figure 14 in Y-K).

As it was stated at the end of page 7 of the Discussion paper, in our case the slope is 4.495, whereas Yver Kwok obtained a mean value of 2.4 for the set of CRDSs they tested. As mentioned in the response R1.m29, we are going to mention in the new version of the manuscript that both plots are tightly connected simply by multiplying: the X-values by 1/400 and the Y-values by 1/1850.

R1.m31) p9: The singular of species is species, so I think it should be "for each species" (here and throughout the paper).

Done. Thanks.

R1.m32) Fig 3: the Y-axis here is odd in terms of units. Not sure what to do about it.

You are correct, we think this is the best option because it is informative.

R1.m33) p11: L14: explain "since CO standards use to drift upward"? When?

What we mean here is that when a CO standard drifts, this drift is generally positive. We are going to indicate it explicitly in the revised version of the manuscript, and cite a few references, for example: https://www.esrl.noaa.gov/gmd/ccl/co_scale.html.

R1.m34) p11 L15: why at different rates? (or perhaps different rates from the target gas). If the 4 tertiary standards are drifting at different rates, one would expect residuals to be increasing in time on the fits as well? It seems that without further evidence, it might be more appropriate to just state that it is likely that the standards and/or target tanks are drifting.

Yes, this is exactly the case for CO as Fig. 4 shows: the calibration-fit RMS residual increases in time for CO. This is mentioned in the discussion manuscript a few lines before.

R1.m35) Fig4: the labels should be on the Yaxis rather than as titles. Not sure if this was stated earlier, but each of these points represents an average of how long and every how often? This could be mentioned in the caption to remind the reader.

Agreed, we are going to include the labels in the Y-axis. Each point represents the assigned value to a target gas in a mole-fraction calibration performed using 4 WMO laboratory standards (every 3 or 4 weeks); except the red dot that represents the calibration-fit RMS residual. We are going to include this information at the end of the caption: "and mole-fraction calibration performed using 4 WMO laboratory standards (every 3 or 4 weeks)".

R1.m36) Figure 5: I don't find this figure particularly useful. If kept, labels should be put in the photo of the various components.

Agreed. We are going to put labels in the photo of the various components.

R1.m37) Figure 6: y-axis is unlabeled, should have the variable even though there are not units on this raw measurement.

You are correct. We are going to label the y-axis using the variable and removing it from the interior of the plot.

R1.m38) p14 L24: 39 minutes seems to be very long, when looking at figure 6, the water vapour could change significantly in that time, especially at the higher H₂O values at the beginning of the test. Is such a long average really required, when you are achieving 1-minute precision of 0.87 ppb?

The experiment lasted many hours. We have checked that using a 39-minute running mean for CO has no significant impact in the accuracy of the data for that experiment. Using a 39-minute running mean instead of a 1-minute running mean, the random noise is reduced by a factor 6 approximately.

Also, given the complex equations presented here for CO water correction, how different is the final result from the internal correction (i.e. the variable "CO" in the raw output)? It would be necessary for the reader to evaluate this and how it depends on the level of water vapour, to see if it's worth implementing.

Agreed. We are going to include a new figure in the revised manuscript to show it.

R1.m39) P15-16, Regarding the -40C trap, can you relate this to a maximum H₂O value you see in the data after that point? What is the magnitude of the water correction at those values, and how different is it to CO₂_dry and CH₄_dry? Rella et al. indicate that at low water vapour values, the internal correction works well. Again, the water vapour tests are cumbersome, especially for field analyzers, in many cases - it would be useful to the readers to know what kind of improvement is gained from the tests as opposed to using the factory correction in cases where there already is partial drying like this.

During the first year in which our CRDS was in operation, no drying was performed. This made necessary the H₂O correction. We are going to include a short paragraph in the revised manuscript providing the information you asked for when partial drying is performed.

R1.m40) P16, L7-8: Awkward phrasing "for not discarding". Perhaps "We retain a pre-processed 30-second mean if the following conditions are met: ". Then rephrase the conditions accordingly (i.e. "the mean values of the following variables are within...") etc.

Done.

R1.m41) L9: condition 2 awkward: was exit supposed to be "exist"?

You are correct. Thanks. Changed.

R1.m42) P16 L17: clarify when 10 minutes are discarded (after a calibration or any sample path switch?).

After any sample path switch. This is going to be explicitly indicated in the revised version of the manuscript.

R1.m43) P18 L14: remove the final "in space", as earlier this sentence stated in space and time.

Done. Thanks.

R1.m44) Fig 11, caption should include the fact that these are 12-hour averages (if that is the case).

Yes, this is the case. We are going to include this information in the caption.

R1.m45) Table 4, first row, month says 2017? I wonder if the information in this table would be better expressed in a figure somehow, with dashed lines indicating the WMO compatibility goals?

Indeed, the first row shows the mean values for the period 2015-2017. We need to change the table to make it clearer. If possible, we would prefer to keep the table.

R1.m46) P21 L4: shown

Done.

R1.m47) In section 6.3, the reason for the CRDS-RGA differences for CO is ascribed as due to the CRDS standard drift, but here in Section 7, it is indicated that the drift did not improve the comparison. Can the authors give any explanation for this? Even if the RGA tanks are also drifting, the correction described in Section 7 would put both data sets relative to the same tanks after all.

Section 6.3 mentioned that only as a hypothesis. We have no explanation for the results obtained in Section 7 concerning the CO comparison. Perhaps the explanation might be in the problems detected recently by the CCL in the CO WMO-X2014A scale (https://www.esrl.noaa.gov/gmd/ccl/co_scale_update.html).

R1.m48) Finally, overall, given the large effort involved in achieving very high accuracy for this data set, do the authors envision prescribing an uncertainty to their measurements? [perhaps this is outside the scope of this paper, but something to think about maybe for the future].

That is outside the scope of this paper. Thanks for suggesting it as something to think about for the future.

“Atmospheric CO₂, CH₄, and CO with CRDS technique at the Izaña Global GAW station: instrumental tests, developments and first measurement results” by Angel J. Gomez-Pelaez et al. (<https://www.atmos-meas-tech-discuss.net/amt-2017-375/>)

Author’s Replies to the Comments of Referee #2

In this paper, the authors present their instrumental set-up to measure greenhouse gases continuously at Izaña global GAW station. The instrument performances are tested and interferences are studied. First ambient air measurements are compared against the historical NDIR and GC systems. **This paper should be published after corrections as detailed below.**

[We acknowledge the comments of the referee.](#)

General comments:

R2.M1) The paper would benefit from an English proofing.

[This is going to be done before submitting the revised version of the manuscript.](#)

Specific comments:

R2.m1) p4: It would be great to have a plot of the inlet pressure tests. Did you only varied between two pressures? Also, it would be good to make this test several time to see if drifts occurs over time and if the results are reproducible as you are using them to correct data.

[Since the effect is quite small, two “extreme” pressures were used to maximize the signal to noise ratio. The test was repeated two different days with the same results. When accounting for this effect the fitting to the CO₂ response function improved significantly in the first calibrations, when we were not so skilled adjusting precisely the CRDS inlet pressure corresponding to each gas cylinder. Therefore, intermediate pressures had been tested indirectly.](#)

[We have performed additional tests to determine this correction, including intermediate pressure points and even a larger pressure range. They confirm our previous findings. In the revised version of the manuscript we are going to detail these new tests and expand the information about the previous tests. Also, we are going to include a plot as requested by the referee.](#)

R2.m2) p4: You mention using smaller inlet pressures differences, does that lead to smaller RMS residuals? Is then the inlet pressure correction useful?

[Being able to get smaller inlet pressures differences decreases the impact of the pressure correction, of course. Keeping small the inlet pressure differences between ambient air and standards is quite difficult. We do think that taking into account the pressure correction keeps us in the safe-side to obtain high-accuracy CO₂ measurements.](#)

R2.m3) p5 l25: From experience, the outletvalve value change with time, depending on the Tdas temperature, after restarting the instrument or when the filters get clogged. It seems safer to operate as you said yourself by reducing the difference in inlet pressure between cylinders and ambient air to avoid the need for an empirical correction.

Note that if Eq. (1) is expanded, only the slope term in OV is kept fixed, since the independent term is, in practice, combined with the independent term of Eq. (6), and the latter equation is updated each time a mole fraction calibration is performed. Therefore, it automatically takes into account hypothetical drifts in the independent term of Eq. (1). The impact in the slope (in OV) by hypothetical drifts in the outlet valve controller is quite limited as it is going to be shown in the revised version of the manuscript.

R2.m4) Section 5: did you perform more than one test to assess the variability? It would be interesting to plot the biases between the assigned dry value and the wet values depending on H₂O for Picarro and your own correction for the three species. On the same subject: p15 l22: what is the level of residual water? Why not invest in a -60 C cryocooler and get rid of any correction as you are using already a cryocooler system? Especially if you refer yourself to the paper of Reum et al. in discussion in AMT (Reum, F., Gerbig, C., Lavric, J. V., Rella, C. W., and Göckede, M.: An improved water correction function for Picarro greenhouse gas analyzers, Atmos. Meas. Tech. Discuss., <https://doi.org/10.5194/amt-2017-174>, in review, 2017.) that shows that the H₂O correction is biased when almost dry due to the sensitivity of the pressure sensor with H₂O.

We performed a few, but kept only this one due to its superior design and performance. We are going to include the plots you mentioned in the revised manuscript. During the first year in which our CRDS was in operation, no drying was performed. This made necessary the H₂O correction. We are going to include a short paragraph in the revised manuscript providing the information you asked for when partial drying is performed. We had a -40 C cryocooler available. Funds are always scarce.

Concerning the Discussion paper you mentioned (Reum et al., 2017), the AMT website indicates: “This discussion paper is a preprint. It has been under review for the journal Atmospheric Measurement Techniques (AMT). The revised manuscript was not accepted”. Therefore, we can not use the results of that manuscript.

R2.m5) Section7: Can the ambient air difference be due to the non-linearity of the RGA-3 or to the fact that the H₂O correction is not good enough? The difference does not seem to increase strongly over time but more to vary around a bias.

We do think the non-linearity of the RGA-3 is well characterized and is taken into account. We discard this might be due to the H₂O correction: the amount of H₂O has been very small since November 2016 due to the -40 C cryocooler. We have no explanation for the bias between the CO measurements you mentioned. Perhaps the explanation might be in the problems detected recently by the CCL in the CO WMO-X2014A scale (https://www.esrl.noaa.gov/gmd/ccl/co_scale_update.html).

Technical comments:

R2.m6) p1 l29: not clear, please rephrase

Done.

R2.m7) p2 l7 replace “being.. much lower” by reducing

Re-phrased following the indications of Referee 1.

R2.m8) p2 l3 replace “ones” by “techniques”

Done.

R2.m9) p2 l26: add “of” after “physical discussion”

Done.

R2.m10) p2 l27: “as follow”

According to the WordReference dictionary, it is correct written as “as follows”.

(<http://www.wordreference.com/es/translation.asp?tranword=as%20follows>)

R2.m11) p3 l6 “serial number” should go before the actual serial number

Done.

R2.m12) p3 l7: remove “to the CRDS”

We do think it is necessary to keep it in order to have a sentence with full sense.

R2.m13) p3 l9: cite as well here Yver Kwok et al. As the tests are described in this paper while the specifications gives the tresholds.

Indeed, the mentioned ICOS-ATC report also describes the recommended tests in the year in which it was published (2016), whereas Yver Kwok included all the CRDS tested along the years since 2008. Along these years the methods were not kept constant but they evolved. Therefore, we are going to re-write the sentences to state clearly that the report also describes the test method.

R2.m14) p3 l11: In Yver Kwok et al. the terminology for the precision test is continuous measurement repeatability (CMR), rephrase for example as “The first test, defined in Yver Kwok et al; as the CMR test consists...”

In the revised manuscript, we are going to include the sentence: “(this test is called continuous measurement repeatability -CMR- by Yver Kwok et al., 2015)”. So, by the way, we are going to cite Yver Kwok et al., 2015, here.

R2.m15) p3 l12 put “being” after “the first hour”. This type of exchange appears throughout the text, please check.

We have changed it following the advice of Referee 1.

R2.m16) p3 l15: Replace precision by CMR

We are going to include both terms.

R2.m17) p3 l18: this test is what was called reproductibility before and in ICOS-ATC LTR or long term repeatability. Add ATC after ICOS as ecosystem or ocean could have defined other terms.

In the revised manuscript, we are going to include the sentence: “(this test is called long-term repeatability -LTR- by Yver Kwok et al., 2015)”, and to add ATC after ICOS.

R2.m18) p3 l24: thresholds

Done.

R2.m19) p4 l2 Replace “Repeatability test” by LTR

We are going to include both terms.

R2.m20) p4 l5 use proper units, mbar not mb

You are correct. We are going to use hPa (= mbar).

R2.m21) p4 27-28 delete “to” before “the computation”

We have re-written the sentence as advised by Referee 1.

R2.m22) p6 l2 delete “tot” before “the raw CH₄”

According to an Oxford dictionary, the usual structure is: “call somebody/something + noun”. However, we are using “call noun to somebody/something” since in the other way the sentence might be confusing because the used “somebody/something” is quite large. We are going to check it during the English proofing.

R2.m23) p6 l12-13 you multiply p84sw by 1000, then p84sw’ should be in ppb contrary to what is mentioned.

Please, look Eq. (5) and the last plot of Figure 3. The coefficient *b* is approximately equal to 2.32. This explains why p84sw’ has no ppb units but it is a raw value.

R2.m24) p6 l28: numerical

Done.

R2.m25) p7 l28 It is a new paragraph and the transition is not smooth, please add a transition.

We are going to write it as a new paragraph and make the transition smoother.

R2.m26) p11 l15 Refer to section 7 for more investigations.

Agreed.

R2.m27) p14 l 7-8: move “being” after “CH₄”, add “s” to coefficient

Done.

R2.m28) p15 l7 what is pph?

This was defined in p13 l3-4: “parts per hundred in mole fraction”. Now it is complemented with: “i.e., centimoles per mole of air”.

R2.m29) p15 l16: why is there two inlets, what is the purposes of switching between the two every day?

This has two purposes: 1) to provide a lot of time to change the flask used to trap H₂O in the air line not used at this moment; 2) to check the consistence between both lines after every switching: a bias between them might indicate a leak in one of the lines (especially in the general inlet, which has a few large unions and several instruments connected to it; or at the flasks connections). We are going to add this explanation in the revised manuscript.

R2.m30) p16 l8: Rephrase “For not discarding” in “To keep”

We have re-written it following the advice of Referee 1.

R2.m31) p18 l18: Can you comment on the reason of the larger differences for CO₂ and CH₄ for these particular months? As it is both for CO₂ and CH₄, it seems to indicate that the CRDS would be the cause?

The larger differences took place in October and November 2016. We do think they were produced by a small leak in the general inlet used by the CRDS (the NDIR and the GC-FID used another general inlet). We are going to add this explanation in the revised manuscript.

R2.m32) p20 l10: Replace “for comparing” by “to compare”

Done. Thanks.

“Atmospheric CO₂, CH₄, and CO with CRDS technique at the Izaña Global GAW station: instrumental tests, developments and first measurement results” by Angel J. Gomez-Pelaez et al. (<https://www.atmos-meas-tech-discuss.net/amt-2017-375/>)

Author’s Replies to the Comments of Referee #3

Gomez-Pelaez et al. present both laboratory and field test results of a commercially available CO₂/CH₄/CO cavity ring-down spectrometer (CRDS). The authors discussed the results within the context of several relevant international programs, e.g. Global Atmosphere Watch (GAW) and the European Integrated Carbon Observation System (ICOS). Being aware of recent development of greenhouse gas measurements using the same type of analyzers, the authors tried to improve the water vapor corrections for CO₂ and CO, and to determine the drift rate for the pressure and temperature sensors located inside the CRDS cavity.

R3.M1) As the development presented here is some sort of changes to or confirmation of the published methods and results, it is therefore in several places an overstatement for novelties. Furthermore, several methods and results are not (yet) convincing based on the presented results, see below.

[We disagree with this comment.](#)

R3.M2) I do agree with the second reviewer that the manuscript will benefit from English editing by a native speaker.

[This is going to be done before submitting the revised version of the manuscript.](#)

R3.M3) The authors tried to present a way of explaining the dependence of the CO₂ measurements on the flow rate, i.e. the outlet valve number, in Sect. 3.1. More information is needed to explain how Eq. 1 was derived. Was it derived from 2-point inlet pressure measurements? Appendix A gives a very nice theoretical analysis; however, I do not find it convincing to support the linear relation between actual CO₂ and raw CO₂. The equation apparently corrects the flow effect, which may actually reflect changes in something else, e.g. cavity temperature or pressure. Please show the raw measurement data to support this empirical equation.

[Since the effect is quite small, two “extreme” pressures were used to maximize the signal to noise ratio. The test was repeated two different days with the same results. When accounting for this effect the fitting to the CO₂ response function improved significantly in the first calibrations, when we were not so skilled adjusting precisely the CRDS inlet pressure corresponding to each gas cylinder. Therefore, intermediate pressures had been tested indirectly.](#)

[We have performed additional tests to determine this correction, including intermediate pressure points and even a larger pressure range. They confirm our previous findings. In the revised version of the manuscript we are going to detail these new tests and expand the information about the previous tests. We also are going to show raw measurements data to support the empirical equation, as requested by the referee.](#)

Concerning the referee's sentence: "The equation apparently corrects the flow effect, which may actually reflect changes in something else, e.g. cavity temperature or pressure", we disagree. The CRDS controls "perfectly" the temperature and pressure of the cavity, with very short transient periods, and these variables are continuously monitored by the CRDS and recorded in the acquired raw data files. Temperature or pressure drifts in the cavity sensors can only have an effect on long-term periods (several months or years). The flow effect due to changes in the inlet pressure affects on short timescales, due to the switching between different "air sources" (ambient air, laboratory standards, and target gas) at slightly different pressures.

R3.M4) Water vapor correction for CO: the authors rearranged (combined) the existing equations to fit a single equation to the experimental data. Statistically, the use of the 4000-data running mean should not change the results? Have the authors tried to fit the equation to the raw data?

The H₂O experiment lasted many hours. We have checked that using a 39-minute running mean for CO has no significant impact in the accuracy of the data for that experiment. Using a 39-minute running mean instead of a 1-minute running mean, the random noise is reduced by a factor 6 approximately. Least-squares fitting is very sensitive to outliers (they have a large weight in the computation of the coefficients to be determined). Therefore, the smoothing of the CO data (in a safe way) through a running mean makes the fit more robust and the determined coefficients have less uncertainty.

R3.m1) With all the efforts to improve the water vapour equations, why did the author decide to include a cooler to dry the air?

Till we got all the materials necessary to install the final plumbing configuration detailed in Sect. 6, we needed to use during one year a simpler configuration without drying. During the first year in which our CRDS was in operation, no drying was performed. This made necessary the H₂O correction.

R3.m2) The use of a large number of symbols makes it difficult to read. I would recommend simplifying them and showing only the necessary ones.

Almost all the symbols shown are necessary. The few ones remaining are shown by completeness and for helping readers to "disentangling" the CRDS raw files

R3.m3) The Fortran 90 code does not make the work novel, and there is even no need to mention it in the main text.

We are going to remove the words "Fortran 90" in the main text, keeping them only at the end of the manuscript in the paragraph called "Code availability".

Atmospheric CO₂, CH₄, and CO with CRDS technique at the Izaña Global GAW station: instrumental tests, developments and first measurement results

Angel J. Gomez-Pelaez^{1,a}, Ramon Ramos¹, Emilio Cuevas¹, Vanessa Gomez-Trueba^{1,2}, Enrique Reyes¹

¹Izaña Atmospheric Research Centre, Meteorological State Agency of Spain (AEMET), Tenerife, Spain.

²Air Liquide España, Delegación Canarias, Tenerife, Spain.

^anow at: [Meteorological State Agency of Spain \(AEMET\), Delegation in Asturias, Oviedo, Spain.](#)

Correspondence to: Angel J. Gomez-Pelaez (agomezp@aemet.es)

Abstract. At the end of 2015, a CO₂/CH₄/CO Cavity Ring-Down Spectrometer (CRDS) was installed at the Izaña Global Atmosphere Watch ([GAW](#)) station (Tenerife, Spain) to improve the Izaña Greenhouse gases GAW measurement programme, and to guarantee the renewal of the instrumentation and the long-term maintenance of this programme. We present the results of the CRDS acceptance tests, the processing of raw data applied through novel numerical codes, and the response functions used. Also, the calibration results, the implemented water vapour correction, the target gas injection statistics, the ambient measurements performed from December 2015 to July 2017, and their comparison with other continuous in situ measurements are described. The agreement with other in situ continuous measurements is good most of the time for CO₂ and CH₄, but for CO is just outside the GAW 2-ppb objective. It seems the disagreement is not produced by significant drifts in the CRDS CO [World-Meteorological-Organization \(WMO\)](#) tertiary standards. The main novelties are: [1\) determination of relationships between flow rate, CRDS inlet pressure and CRDS outlet valve aperture; 2\) determination of a slight CO₂ correction that takes into account changes in the inlet pressure/flow rate as well as its stability over the years; 3\) detailed justification of the use of virtual tanks to monitor the response function changes in time; 4\) drift rate determination for the pressure and temperature sensors located inside the CRDS cavity; 5\) novelties in the determination of the H₂O correction for CO; and 6\) determination and discussion of the origin of the CRDS-flow inlet pressure and H₂O dependences.](#)

1 Introduction

A CO₂/CH₄/CO ~~CRDS~~ (Cavity Ring-Down Spectrometer) ([CRDS](#)) was installed at the Izaña ~~Global GAW~~ (Global Atmosphere Watch) ([GAW](#)) station (Tenerife, Spain) at the end of 2015 in order to improve the Izaña ~~GHG~~ (Greenhouse-gases) ([GHG](#)) GAW measurement programme, and guarantee the long-term maintenance of this programme. The incorporation of the CRDS technique for the measurement of atmospheric CO₂, CH₄, and CO mole fractions was a

recommendation of the World Meteorological Organization (WMO) World Calibration Centre (WCC) -~~EMPA~~ after its audit carried out at the Izaña Observatory (IZO) in September 2013 (EMPA, 2013).

The GAW programme of the ~~World Meteorological Organization (WMO)~~ requires high precision and accuracy in atmospheric GHG measurements, which are more stringent for trace gases with a longer lifetime ~~higher as higher the~~

5 ~~lifetime of the corresponding trace gas~~ in the atmosphere ~~is~~. The reason is that atmospheric GHG spatial gradients contain useful information about the spatial distribution of the surface sources and sinks of these trace gases (Chevalier et al., 2010), but these gradients decrease in absolute value as the trace gas lifetime increases (Patra et al., 2014). The GAW required compatibility between laboratories is 0.1 ppm (parts per million in dry mole fraction; i.e., micromoles per mole of dry air) for carbon dioxide in the Northern Hemisphere and 0.05 ppm in the Southern Hemisphere; for methane, 2 ppb (parts per

10 ~~American~~ billion in dry mole fraction; i.e., nanomoles per mole of dry air); and for carbon monoxide, 2 ppb (WMO, 2015).

CRDS technique (Crosson, 2008) has improved considerably the stability and precision in the raw measurements compared to those of older techniques (e.g., ~~NDIR~~-Non Dispersive InfraRed analysers-~~NDIRs~~-, ~~GC-FID~~-Gas Chromatography ~~GC~~-with Flame Ionization Detector ~~FID~~-, and GC with ~~RGD~~ -Reduction Gas Detector- ~~RGD~~-), ~~being~~ therefore, the required frequency of use of calibrating/reference gases to achieve the GAW ~~DQOs~~ (Data Quality Objectives) (DQOs) ~~is~~ much lower.

15 Additionally, this spectrometric technique does not require chromatographic gases (e.g., carrier gas, make up gas, and FID gases for maintaining the flame), which are expensive, and require great logistics efforts at remote stations. Zellweger et al. (2016) found out, when evaluating the results of scientific audit performed at GAW stations, that the results using newer spectroscopic techniques (CRDS and ~~OA-ICOS~~-Off-Axis Integrated Cavity Output Spectrometry ~~OAICOS~~-), in general, are better than those obtained with older ~~techniques~~.

20 The Izaña Observatory (~~IZO~~) is a Global GAW station located at 2373 metres a.s.l. on Tenerife (Canary Islands, Spain), usually above a strong subtropical temperature inversion. Since it is located at the summit of a mountain, during night-time there are North-Atlantic-free-troposphere background conditions, whereas during daytime there is a slight perturbation of these conditions by the arrival of an upslope thermal wind close to the terrain surface (e.g., Cuevas et al., 2013; Gomez-Pelaez et al., 2013; Rodríguez et al., 2009). Detailed information about the numerous measurement programmes operative at

25 IZO are provided by Cuevas et al. (2015).

This paper presents the implementation of a CRDS G2401 at IZO and the independent development of novel ~~numerical Fortran 90~~ codes for raw data processing. The main novelties are: 1) determining the relationships between flow rate, CRDS inlet pressure and CRDS outlet valve aperture; 2) determining a slight CO₂ correction that takes into account changes in the inlet pressure/flow rate (as well as its stability over the years), and attributing it to the existence of a small

30 spatial inhomogeneity in the pressure field inside the CRDS cavity; 32) detailed justification of the use of virtual tanks to monitor the response function changes in time; 43) providing equations to determine the drift rate of the pressure and temperature sensors located inside the CRDS cavity; 54) introducing some novelties in the determination of the H₂O correction for CO; and 65) physical determination and physical discussion of the origin of the inlet pressure and H₂O dependences of the CRDS flow.

The structure of this article is as follows. We firstly detail (Sect. 2) the results obtained in the initial tests performed to the Izaña CRDS (precision, repeatability, sensibility to inlet gas pressure, response function...) as well as the relationships between flow rate, CRDS inlet pressure and CRDS outlet valve aperture; and the pre-processing applied to the raw data (Sect. 3). Secondly, we analyse the results of the calibrations performed every 3-4 weeks since the end of 2015 using ~~Tertiary~~ WMO tertiary standards, and provide some details on the response functions used and the numerical processing software developed to evaluate the calibrations (Sect. 4). Thirdly, some details of the obtained and implemented water vapour correction are provided (Sect. 5). Finally, the ambient measurements carried out until now are presented, as well as some details in the numerical processing software developed to obtain the ambient air CRDS measurements from raw data and calibration results, and compared with those obtained with other Izaña in situ measurement instruments (Sect. 6). In Sect. 7, a preliminary independent assessment on the drift rates of the CRDS CO standards is performed. The main conclusions are outlined in Sect. 8. ~~In Appendix A, Aa~~ note concerning the inlet pressure (Sect. 2.4) and H2O dependences of the CRDS flow and the spatial inhomogeneity of the pressure field inside the CRDS cavity is presented (Appendix A). Additionally, we very briefly describe some few more novelties in the Izaña GHG measurement programme since the WMO/IAEA Meeting on Carbon Dioxide, Other Greenhouse Gases and Related Tracers Measurement Techniques that took place in the year 2015 (GGMT-2015) in(see Appendix B).

2 Acceptance tests performed to the CRDS

A Picarro G2401 CRDS analyser (~~serial number~~ CFKADS2196 ~~serial number~~) for measuring CO₂, CH₄, CO and H₂O was installed on November 2015 at IZO. Several acceptance tests were performed to the CRDS at the station, roughly following the recommendations provided by the European Integrated Carbon Observation System (ICOS)-Atmospheric Thematic Centre (ATC) (ICOS-ATC, 2016). For processing the data associated to the tests, the raw values for CO₂ (not dry), CH₄ (not dry), CO and H₂O of the “Synchronized DataLog_User” files were used.

2.1 Continuous measurement repeatability test

The first test was what ICOS-ATC (2016) ~~calls a~~ “Precision test”. This test is called continuous measurement repeatability -CMR- by Yver Kwok et al. (2015), which consists in measuring a gas cylinder (filled with dry natural air) over 25 hours, ~~being~~ rejecting the first hour ~~rejected as~~ -(stabilization time). As Table 1 shows, the results (standard deviations) obtained in this test were well within the threshold established by ICOS-ATC (2016). Note that the precision for the H₂O measurements indicated by the manufacturer of the CRDS is: <200 ppm for 5-second averages, and < 50 ppm for 5-minute averages. Therefore, it is reasonable obtaining small (in absolute value) negative values (-2.8 ppm) for H₂O when measuring dry air, since, taking into account the precision of the instrument, these values are completely compatible with 0.0 ppm.

30

Raw data	CO ₂ S.D.(ppm)	CH ₄ S.D.(ppb)	CO S.D.(ppb)
----------	---------------------------	---------------------------	--------------

average length	Obtained/ICOS-threshold	Obtained/ICOS-threshold	Obtained/ICOS-threshold	Mean H2O (ppm)
1 minute	0.013 / 0.050	0.19 / 1.0	0.87 / 2.0	-2.8
60 minutes	0.009 / 0.025	0.14 / 0.5	0.16 / 1.0	-2.8

Table 1. Results obtained during the “Precision test” (CMRsee main text) and ICOS-threshold values for two averaging lengthstimes (1 and 60 minutes). S.D. means “Standard Deviation” of the sample of 1-minute (or 60-minute) means obtained through the full duration of the test.

5

2.2 Long-term repeatability test

The second test performed was a “Repeatability test” (this test is called long-term repeatability -LTR- by Yver Kwok et al., 2015). According to the ICOS-ATC (2016)terminology, it consists in measuring alternately a gas cylinder (filled with dry natural air) during 30 minutes and ambient air (not dried) during 270 minutes over 72 hours. Statistics are based only on the last 10-minute-average data for each gas cylinder “injection”. Indeed, we used 2 cylinders, each one measured every 5 hours, with the following measurement cycle: cylinder 1 during 40 minutes, wet ambient air during 20 minutes, cylinder 2 during 40 minutes, and wet ambient air during 200 minutes. Table 2 shows the obtained results for each tank and 10-minute average period: 20-30 minutes and 30-40 minutes. The results were well within the thresholds established by ICOS-ATC (2016). Note that the S.D.’s in Table 2 (associated to 10-minute means) are larger for CO2 and CH4 (but lower for CO) than the S.D.’s in Table 1 associated with 1-minute means. This means the decrease in the random noise due to the increase in the averaging time is countered by the increase in the S.D. due to the larger response drift in the longer test (this is not the case for CO).

15

Cylinder	10-minute average period	CO2 S.D.(ppm) Obtained/ICOS-threshold	CH4 S.D.(ppb) Obtained/ICOS-threshold	CO S.D.(ppb) Obtained/ICOS-threshold	Mean H2O (ppm)
1	20-30 min.	0.016 / 0.050	0.23 / 0.5	0.23 / 1.0	<u>-1.3</u>
1	30-40 min.	0.021 / -	0.34 / -	0.28 / -	<u>-1.8</u>
2	20-30 min.	0.016 / 0.050	0.23 / 0.5	0.35 / 1.0	<u>-1.2</u>
2	30-40 min.	0.026 / -	0.31 / -	0.31 / -	<u>-1.4</u>

Table 2. Results obtained during the “Repeatability test” (LTRsee main text) and ICOS-threshold values. S.D. means “Standard Deviation” of the sample of 10-minute means obtained through the full duration of the test.

20

2.3 Ambient pressure sensitivity test

The third test performed was an ambient pressure sensitivity test ~~for~~ of the measurements carried out ~~during~~ for the mentioned period of 72 hours. ~~No pressure chamber was used, in the same way done by Yver Kwok et al. (2015). Note that this CRDS is not meant for use on aircraft, where large pressure changes might occur. This test provides an upper-limit for the ambient pressure sensitivity, since there might be instrumental drift not attributable to atmospheric pressure changes.~~ The results obtained were: 0.04 ppb/10mhPa for CO, 0.0038 ppm/10mhPa for CO₂, and 0.047 ppb/10mhPa for CH₄. Those sensitivities ~~are not significant can be considered as small taking into account the GAW DQOs and the typical variation range of the atmospheric surface pressure.~~ Our main purpose with this test was to confirm we had not one of the CRDS units whose CO measurements are affected by natural ambient pressure changes.

2.4 Relationships between inlet pressure, flow rate and outlet valve aperture. Inlet pressure sensitivity test

Due to its importance for the present article, we detail firstly the relationships we have found between inlet pressure, flow rate and outlet valve opening.

According to the information provided by the manufacturer (Rella, private communication), there are both a proportional valve and a physical critical orifice in the inlet system of the G2401 CRDS cavity. The proportional valve is opened slowly at start-up to ensure that the flow changes smoothly, but after this start-up procedure, the valve is set to full open, and the flow is set by the critical orifice. There is also a proportional valve at the outlet of the cavity and upstream the vacuum pump. The cavity (absolute) pressure is kept at 186.7 hPa (140 Torr) by controlling the opening of the Outlet Valve (OV).

A choked flow is a flow through a critical orifice in which the following condition holds for the inlet to outlet (absolute) pressure ratio (Van den Bosch & Duijm, 2005):

$$\frac{p_i}{p_o} \geq \left(\frac{\gamma+1}{2}\right)^{\gamma/(\gamma-1)} \quad (1),$$

where p_i is the inlet (absolute) pressure, p_o is the outlet (absolute) pressure, and γ is the ratio of specific heats (c_p/c_v) for the considered gas. For dry air, γ is equal to 1.4 and the right-hand side of Eq. (1) is equal to 1.893. In a choked flow, the speed is supersonic just downstream the orifice and the flow rate does not depend on the downstream quantities (because “information” cannot propagate faster than sound). Since the minimal recommended inlet (absolute) pressure for the CRDS G2401 is 400 hPa, and the cavity pressure is 187 hPa (140 Torr), the flow in the inlet critical orifice is always choked. This is the reason why the flow through the CRDS cavity depends only on upstream quantities (mainly the inlet pressure) and not on the cavity quantities. However, for flight-ready models, the critical orifice is located at the outlet of the CRDS cavity, and therefore, the inlet pressure for the orifice is the cavity pressure, which is kept constant.

The theoretical equation relating the standard volumetric flow (F) with the inlet quantities for a choked flow is (Van den Bosch & Duijm, 2005):

$$F = C_d \cdot A \cdot p_i \cdot \frac{T_s}{p_s} \cdot \left[\frac{\gamma \cdot R}{T_i} \cdot \left(\frac{2}{\gamma+1}\right)^{(\gamma+1)/(\gamma-1)} \right]^{1/2} \quad (2),$$

where T_s and p_s are the standard (absolute) temperature (273.15 K) and pressure (1013.25 hPa), respectively, T_i is the inlet (absolute) temperature, R is the gas constant, C_d is the discharge coefficient (dimensionless) and A is the hole cross-sectional area. Equation (2) shows that the standard volumetric flow is proportional to the inlet (absolute) pressure and inversely proportional to the square root of the inlet (absolute) temperature.

5 As indicated in Sect. 6, the ambient air/gas standard plumbing configuration operative since 28 November 2016, includes a Red-Y mass flow meter (MFM) downstream the CRDS, but upstream the vacuum pump. There is an expansion volume between the MFM and the vacuum pump to smooth the pulses induced in the flow by the pump.

The fourth acceptance test was an inlet pressure sensitivity test when measuring a gas cylinder filled with dry natural air. This test was performed on 25 and 26 November 2015. Additional more complete tests of that type were performed in July and August 2018.

10 Figure 1 shows results of that second set of tests (no flow rate measurements were carried out during the first set of tests) performed on 4 non-consecutive days in which dry natural air coming from a standard was measured during many consecutive hours changing the CRDS inlet pressure every hour (sometimes more than an hour), discarding the first 20 minutes after the pressure change, and keeping the mean of the measurements till the next pressure change. The sequences of pressures used were not monotonic but with jumps up and down. Pressure was measured using the regulator gauge and then ambient pressure was summed. On 24 July 2018 the test was performed using a cylinder regulator of a different type than the one used the other 3 days. As Fig. 1 shows, the relationship between the CRDS inlet pressure and the flow rate is linear. Table 3 shows the coefficients and R^2 obtained fitting a straight line to the data of each test. The linear fits are very good (R^2 is almost 1) and very similar (the first one is slightly different probably due to the use of a different regulator and a larger pressure range).

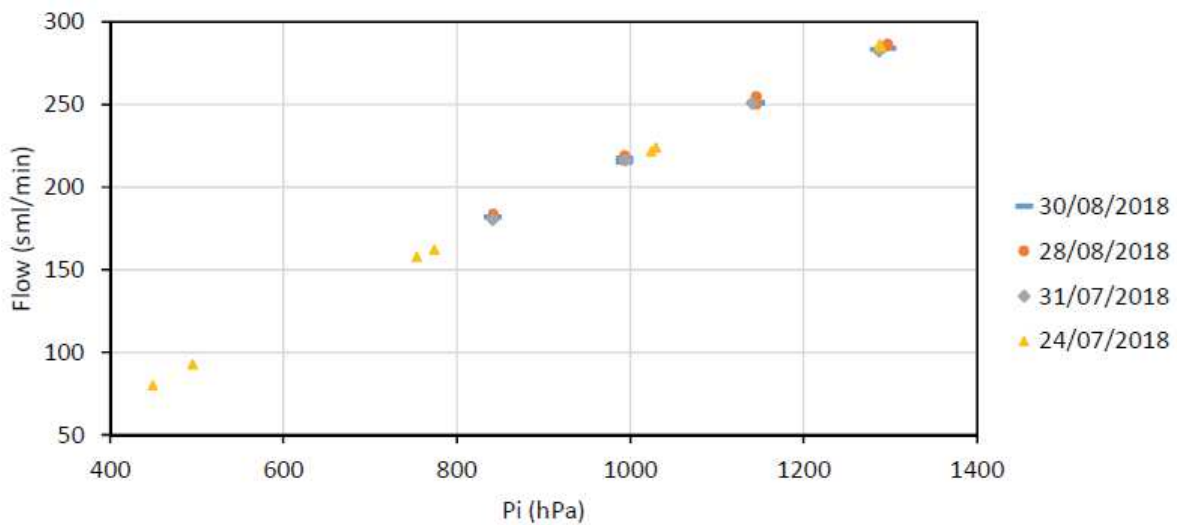

Figure 1. Results of tests performed on 4 non-consecutive days in which dry natural air coming from a standard was measured during many consecutive hours changing the CRDS inlet pressure every hour or longer (see details in the main text of the article). Pi is the CRDS inlet pressure and Flow is the flow measured downstream the CRDS.

<u>Test</u>	<u>Slope (sml/[min·hPa])</u>	<u>Intercept (sml/min)</u>	<u>R²</u>
<u>24/07/2018</u>	<u>0.244</u>	<u>-27.9</u>	<u>0.9998</u>
<u>31/07/2018</u>	<u>0.229</u>	<u>-12.2</u>	<u>0.9996</u>
<u>28/08/2018</u>	<u>0.228</u>	<u>-9.5</u>	<u>0.9984</u>
<u>30/08/2018</u>	<u>0.226</u>	<u>-8.4</u>	<u>0.9996</u>

5 **Table 3. Coefficients and R² obtained fitting a straight line to the test data shown in Fig. 1.**

Figure 2 shows results of the mentioned first and second sets of inlet pressure sensitivity tests. The first tests were performed alternating only between two inlet pressures, using cylinder regulators different from those used in the second set of tests. As Fig. 2 shows, the relationship between the CRDS inlet pressure and OV is linear. Table 4 shows the coefficients and R² obtained fitting a straight line to the data of each test. The linear fits are very good (R² is very near 1) and have very similar slopes (except for the test performed using a larger pressure range).

10

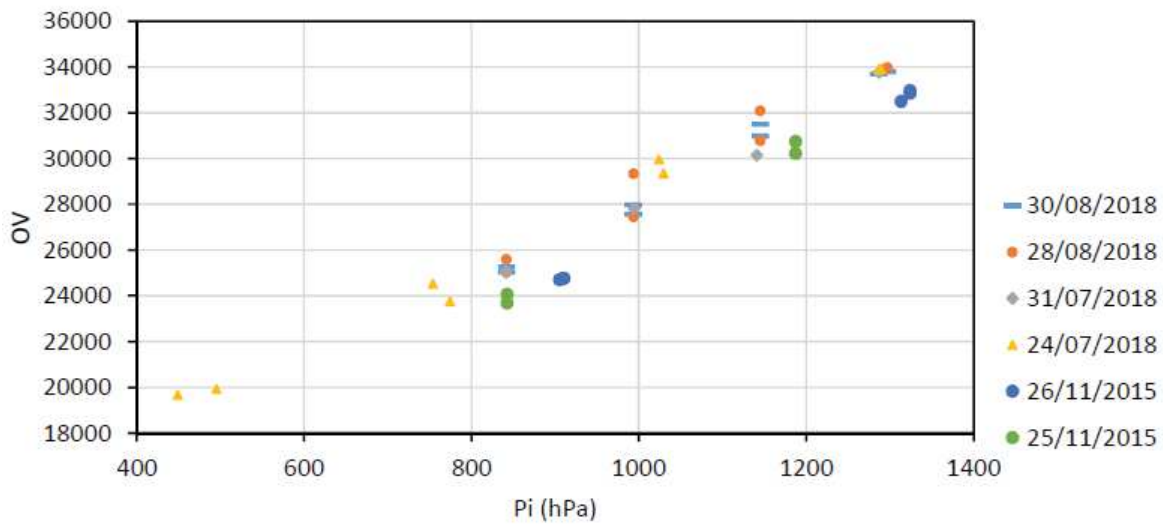

Figure 2. Results of the mentioned first and second sets of inlet pressure sensitivity tests. Pi is the CRDS inlet pressure and OV is the aperture of the CRDS-cavity outlet valve.

15

<u>Test</u>	<u>Slope (hPa⁻¹)</u>	<u>Intercept</u>	<u>R²</u>
<u>25/11/2015</u>	<u>19.2</u>	<u>7720</u>	<u>0.9954</u>

<u>26/11/2015</u>	<u>19.5</u>	<u>7020</u>	<u>0.9996</u>
<u>24/07/2018</u>	<u>17.6</u>	<u>11300</u>	<u>0.9913</u>
<u>31/07/2018</u>	<u>19.2</u>	<u>8710</u>	<u>0.9913</u>
<u>28/08/2018</u>	<u>19.1</u>	<u>9320</u>	<u>0.9659</u>
<u>30/08/2018</u>	<u>19.5</u>	<u>8660</u>	<u>0.9934</u>

Table 4. Coefficients and R² obtained fitting a straight line to the test data shown in Fig. 2.

Figure 3 shows results of the inlet pressure sensitivity tests for CO₂, CH₄ and CO, using OV as independent variable. Since the cylinders used were not unique, for each test we use the difference respect to the mean raw mole fraction measured during the whole test and the symbol “d” to indicate such difference. As Fig. 3 shows, the relationship between dCO₂raw and OV is linear. Note that the dCO₂raw values are quite small and therefore it is not surprising there are some noise in the fit, but the slopes obtained in the 6 tests are consistent. For dCH₄raw there is a linear relationship too, but noisier. For dCOraw there is not any significant linear relationship. Table 5 shows the mean slope and intercept for each trace gas as well as the associated standard deviations. Those numbers confirm the previous sentences concerning the statistical significance of the linear fits for CO₂, CH₄ and CO.

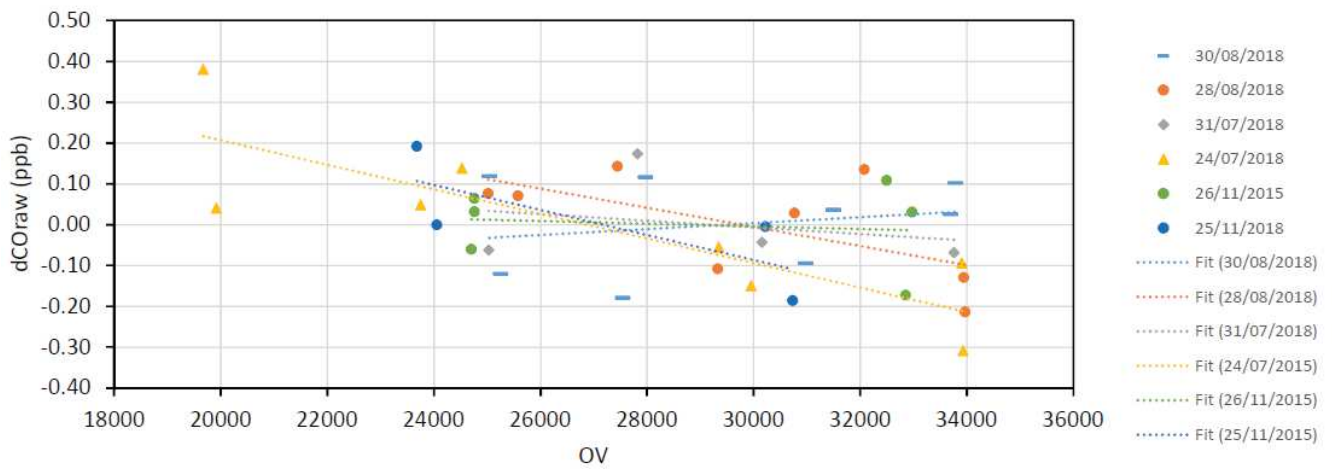
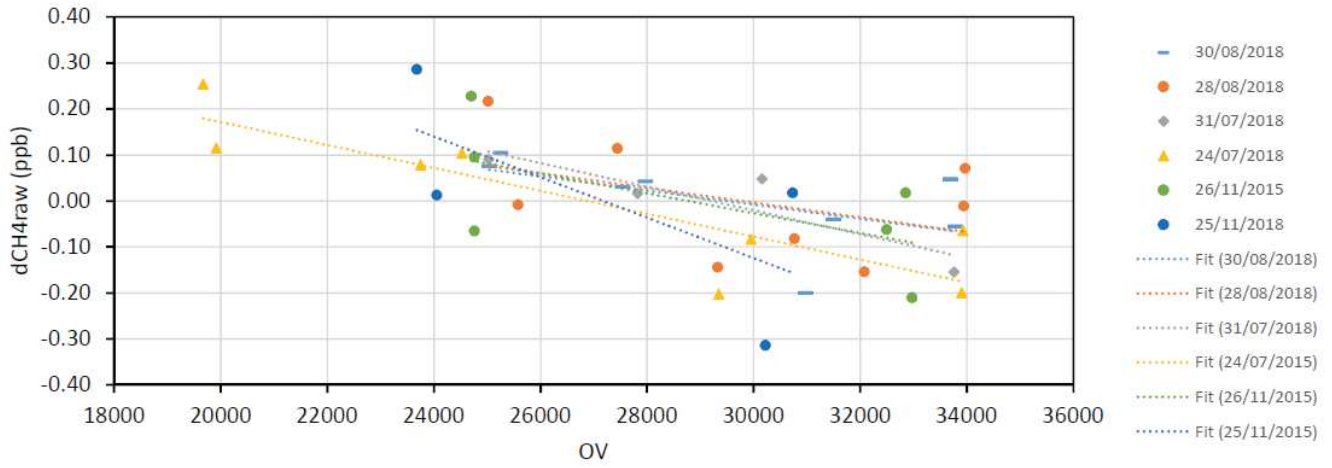
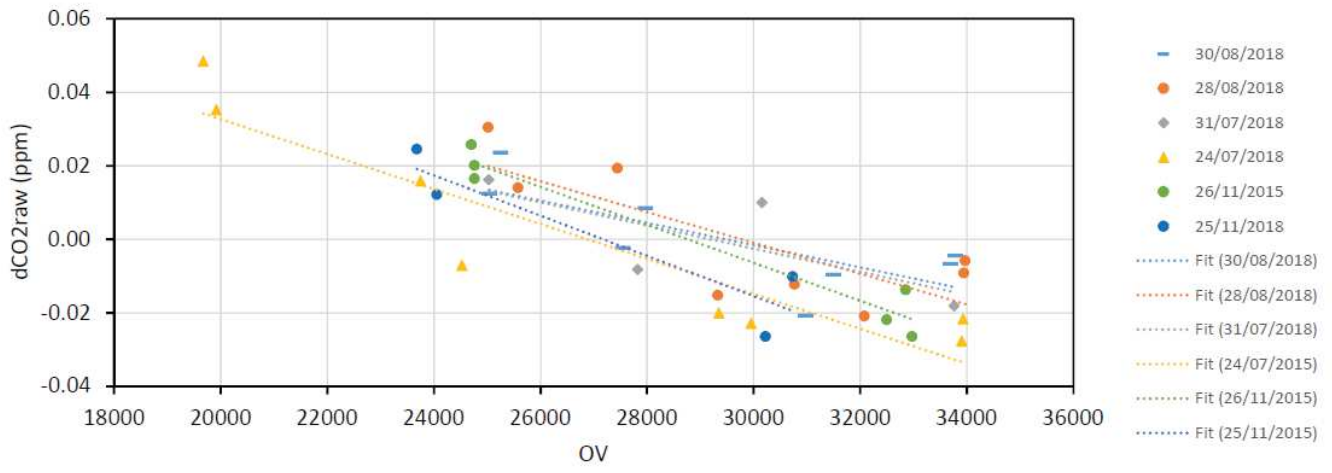

Figure 3. Results of the inlet pressure sensitivity tests for CO₂, CH₄ and CO, using OV as independent variable. For each test, “d” denotes the difference respect to the mean raw mole fraction measured during the whole test.

<u>Trace gas</u>	<u>Mean slope</u>	<u>Stand.Dev.</u>	<u>MEAN INTERCEPT</u>	<u>STAND.DEV.</u>
<u>CO₂</u>	<u>-4.29·10⁻⁶ ppm</u>	<u>1.03·10⁻⁶ ppm</u>	<u>0.122 ppm</u>	<u>0.026 ppm</u>
<u>CH₄</u>	<u>-2.46·10⁻⁵ ppb</u>	<u>1.05·10⁻⁵ ppb</u>	<u>0.695 ppb</u>	<u>0.271 ppb</u>
<u>CO</u>	<u>-1.47·10⁻⁵ ppb</u>	<u>1.56·10⁻⁵ ppb</u>	<u>0.409 ppb</u>	<u>0.433 ppb</u>

Table 5. Mean slope and intercept for the fits (Fig. 3) associated to each trace gas (as well as the associated standard deviations) in the inlet pressure sensitivity tests.

~~The fourth test was an inlet pressure sensitivity test when measuring a gas cylinder filled with dry natural air. The cylinder air was continuously measured during more than 13 hours in two consecutive days, and the regulator low pressure was changed alternatively between 8 psi and 2 psi, keeping the same pressure in the regulator during at least one hour each time.~~

Taking into account the linear relationship between inlet pressure and OV, and the values shown in Table 5, the sensitivities obtained were: 0.00·10⁻² ppb/kPa (since the slope is not statistically significant) for CO, -0.83·10⁻³ ppm/kPa for CO₂, and -0.47·10⁻² ppb/kPa for CH₄, which are quite small except for CO₂ (e.g., 30 kPa produces a bias of -0.025 ppm in CO₂). Since the CRDS inlet pressure can be slightly different (e.g., differences of a few tens of kPa) may be present) when changing the sample (laboratory standards, target gases and ambient air), and in order to be able of achieving a very accurate response function for CO₂, we empirically correct for this effect as explained in Sect. 3.1.

2.5 Calibration curve fitting test

The fifth test was fitting response curves when calibrating with 4 WMO tertiary standards (6 cycles, 2.5 hours/cycle, each standard is measured during 30 consecutive minutes as well as a target gas). When performing a linear fitting for CH₄, the Root Mean Square (RMS, accounting for the effective degrees of freedom) residual was 0.143 ppb (very small). When performing a linear fitting for CO, the RMS residual was 0.067 ppb (very small). However, when performing a linear fitting for CO₂, the RMS residual was 0.0395 ppb, which is larger than the values we usually obtain with our NDIR-based measurement system for CO₂ when using a quadratic fitting (Gomez-Pelaez & Ramos, 2011). Moreover, when using a quadratic fitting for the CRDS CO₂, the RMS residual was 0.0284 ppm, still slightly worse than that of our NDIR-based systems. Finally, when correcting the raw CO₂ from the inlet pressure sensitivity and then performing a quadratic fitting, the RMS residual was 0.0219 ppm, which is similar to the values obtained with our NDIR-based systems. During ~~the that first~~ calibration described above, the inlet pressure differences were especially intense. We have improved our skills since then getting smaller inlet pressure differences during the calibrations.

3: Data acquisition and pre-processing

~~We call p~~Pre-processing refers to the computation of raw-data 30-second means and corresponding standard deviations using the DataLog_User files (not the synchronized ones), as well as ~~to~~the computation of some derived variables detailed below. We have developed the pre-processing software ~~in Fortran 90~~, as well as the calibration and ambient-air processing software.

- 5 For the computation of 30-second means and standard deviations, we take into account the so called “species” field. The species code is different for each spectral range in which the measurements are performed. There are 4 spectral ranges and 3 lasers, since two nearby spectral ranges are scanned with the same laser (see Chen et al., 2010, and Chen et al., 2013, for details about these spectral ranges). ~~(i.e., which informs about t~~The fields ~~that have been~~updated in each file line are those related with the spectral lines measured in the corresponding spectral range. ~~;~~ The DataLog_User file contains~~there are~~ 1.7
- 10 lines/second and these lines follow this time sequence of species: 1, 2, 4 and 3. The raw variables associated to each “species” value are: a) Species=1, CO₂, peak_14 (*p14*), and CO; b) Species=2, CH₄, CO_{2_dry}; c) Species=3, H₂O, h_{2o_reported} (*hr*), CO_{2_dry}, and CH_{4_dry}; and d) Species=4, CO, b_h_{2o_pct} (*bh*), and peak_{84_raw} (*p84*); where CO₂ and CH₄ are raw values not corrected from H₂O dilution nor pressure broadening, whereas CO_{2_dry} and CH_{4_dry} have been (factory) corrected from those effects, *p14* is the raw value associated to the main CO₂ peak, CO is already (factory)
- 15 corrected from the CO₂ and H₂O influences, H₂O is the calibrated value obtained from *hr*, which is the reported H₂O raw value associated to the main H₂O peak (in the CH₄-peak laser wavelength range), *bh* is the H₂O raw value associated to the secondary H₂O peak (in the CO-peak laser wavelength range), and *p84* is the raw value associated to the CO peak. Additionally, there are other raw variables not associated to a single “species” value that we use: Cavity Pressure (*CP*), Cavity Temperature (*CT*), Multi Position Valve (MPV) Position (MPVP), Outlet Valve (*OV*), and Solenoid Valves (*SV*).
- 20 Note that the Picarro software is able to control both solenoid (up to 6) and MPV (just one) valves for the gas handling system, and stores the positions of the valves in the same file than the output data for the measured trace gases. The information on the positions of the solenoid valves is codified in a single natural number (SV).

A 30-second mean is accepted when: a) at least 85% of the expected data is present; and b) all the instantaneous data have the same *MPVP* and *SV* values. Additionally, a counter called *npcmc* is assigned to each 30-second mean. It indicates the

25 number of consecutive 30-second means with the same configuration for both, *MPVP* and *SV*.

3.1 Inlet pressure sensitivity correction for raw CO₂

~~As pointed out by Karion et al. (2013), the Picarro G2401 CRDS has a critical orifice (indeed a proportional valve kept always at the same aperture or closed) at the inlet of the cavity, and a proportional valve at the outlet of the cavity and upstream the vacuum pump. Since the cavity pressure is kept at 140 Torr (by controlling the opening of the Outlet Valve),~~

30 ~~the flow in the critical orifice is supersonic, and therefore, ideally only depends on the CRDS upstream quantities (mainly on the inlet pressure; see Appendix A for more details) and not on the cavity quantities. Therefore, we can assume a linear~~

~~relationship between the CRDS inlet pressure and the Outlet Valve aperture for small deviations with respect to reference values.~~

~~We use \dagger the original empirical relationship we determined through the inlet pressure sensitivity test mentioned in Sect. 2.4, which leads to the following Outlet-Valve-corrected raw CO₂:~~

5
$$CO2_{ovc} = CO2_{raw} + 0.04 \cdot (OV - 26468.15)/7700 \quad (3\dagger).$$

~~CO₂_{ovc} is the raw value we use for the CO₂ processing. These slope and intercept values are compatible with the corresponding mean values shown in Table 5 (distant less than 1 standard deviation from the corresponding mean).~~

~~CO₂_{ovc} is corrected from the inlet pressure sensitivity but not for the H₂O dilution and pressure broadening. According to the knowledge of the authors, this is a new correction not considered previously in the scientific literature.~~

10 ~~Note that if Eq. (3) is expanded, only the slope term in OV is kept fixed, since the independent term is, in practice, combined with the independent term of the mole-fraction calibration curve (see Sect. 4), which is updated periodically. Therefore, this automatically takes into account hypothetical drifts in the independent term of Eq. (3). As Fig. 2 and Table 4 show, the slope of the linear relationship between OV and Pi is consistent through the years, and no significant change in time is observed in the slope of the linear relationship between dCO₂_{raw} and OV. Note that if we average the addends of Eq. (3) and subtract~~
15 ~~those to Eq. (3), we obtain an equation for dCO₂_{raw} that is linear in OV and has an intercept that depends on the average OV. This explains why in Fig. 3a, the fit for the test with the largest OV range (smallest average OV) is below the rest of test fits.~~

~~In Appendix A, we provide a plausible physical explanation for this effect, after physically determining the inlet pressure and H₂O dependences of the CRDS flow and physically arguing that the pressure field inside the CRDS cavity is slightly inhomogeneous. Note that our arguments that point out to the fact that the inhomogeneity of the pressure field inside the cavity due to the flow produces the CO₂_{raw} dependence on OV, seem to be also supported by the following fact: the relative effect of the flow on CO₂_{raw} and CH₄_{raw} is roughly the same. Note that dividing the slopes of Table 5 by the typical ambient air mole fraction at IZO (405 ppm for CO₂ and 1880 ppb for CH₄) we obtain: $1.06 \cdot 10^{-8}$ for CO₂ and $1.31 \cdot 10^{-8}$ for CH₄.~~

25 3.2 Raw CH₄

We call CH₄_{raw} to the raw CH₄ multiplied by 1000 (to have ppb units) and use it for the CH₄ processing. Note that CH₄_{raw} is the wet value not corrected from H₂O dilution and pressure broadening.

3.3 Computed raw wet CO

30 The CO value provided by the G2401 CRDS includes the correction due to H₂O dilution and pressure broadening. However, what we use for CO processing is the CO raw value (wet) that Picarro calls peak84_spec_wet (*p84sw*), which is *p84* corrected from the H₂O and CO₂ spectral peak overlapping (interference that changes the zero of *p84*). To compute it, we use the equations that our G2401 employs internally (Rella, private communication):

$$co2_p14 = 0.706630873 \cdot p14 \quad (42),$$

$$p84sw = p84 + off + w1 \cdot bh + wc \cdot bh \cdot co2_p14 + w2 \cdot bh^2 + c1 \cdot co2_p14 \quad (53),$$

where $off=-0.000800885106752$, $w1=-0.0334069906515$, $wc=-8.2480775807e-7$, $w2=0.00633381386844$, and $c1=8.87510231866e-6$. We call $p84sw'$ to $p84sw$ multiplied by 1000. That is the raw value we use for the CO processing,

5 i.e., it is the wet value not corrected from H2O dilution and pressure broadening nor converted to ppb units.

4 Calibrations and Response Functions

After processing, the measurements we carry out with the CRDS are in the following WMO scales: X2007 for CO₂, X2004A for CH₄ and X2014A for CO, since we use 4 multi-species WMO tertiary standards filled (with dried natural air) and calibrated by the WMO ~~CCL~~ (Central Calibration Laboratory) (CCL) for these gases

10 (<https://www.esrl.noaa.gov/gmd/ccl/>).

In each cycle of a calibration we use the 4 WMO tertiary standards and 2 target gases that act as unknowns. Each tank is measured continuously during 30 minutes every cycle. From December 2015 to August 2016, each calibration had 5 cycles and a calibration was performed every 3 weeks. From September 2016 till present, each calibration has 2 cycles and a calibration is performed every month. In the first period, we adopted a conservative strategy and after analysing the obtained

15 results in detail we concluded that the second calibration strategy provided ~~accurate enough~~ results that satisfied our accuracy requirements. Note that since there are technicians at the station every day, the regulators of the WMO tertiary standards remain closed between calibrations. This helps avoid any hypothetical problem of drifting in the standards due to very small leaks or differential diffusion inside the regulators that might propagate ~~to~~ the interior of the ~~cylinders~~ standards through the open valves by diffusion during the weeks the standard air remains static inside the regulators. For CO₂ and

20 CH₄, the last 10 minutes of each gas injection are used. However, for CO, the last 20 minutes are used since CO measurements are noisier (i.e., better signal to noise ratio when incrementing the averaging period) and 10 minutes of stabilization time is enough for CO (numerical details not presented here).

The calibration processing is done using our own ~~Fortran 90~~ numerical code. For processing a calibration, the code computes the mean raw response for each tank and species, and then performs a least-square fit to the respective response function

25 detailed below. For CH₄ and CO, we use linear response functions:

$$CH4_{raw} = b \cdot CH4 + c \quad (64), \text{ and}$$

$$p84sw' = b \cdot CO + c \quad (75),$$

where CH₄ and CO are the ~~real~~ dry mole fractions (the gas standards are dry) in ppb assigned by the CCL on the WMO scales. ~~For CO₂, we have preferred to use a quadratic fit instead of a linear fit for CO₂, since the RMS residual is significantly smaller: considering the first 13 calibrations, the mean RMS residual for linear fits is 0.035 ppm, whereas for quadratic fits it is 0.020 ppm. As mentioned in Sect. 2.5, we have chosen the quadratic fit for CO₂ to obtain RMS residuals~~

30 significantly smaller: considering the first 13 calibrations, the mean RMS residual for linear fits is 0.035 ppm, whereas for quadratic fits it is 0.020 ppm. As mentioned in Sect. 2.5, we have chosen the quadratic fit for CO₂ to obtain RMS residuals

as smaller as we obtain with the IZO NDIR-based measurement system. The quadratic function with raw signal slightly corrected in the outlet valve aperture is used (as described in Sect. 3.1) is:

$$CO2_{ovc} = a \cdot CO2^2 + b \cdot CO2 + c \quad (86),$$

where CO2 is the real-dry mole fraction in ppm assigned by the CCL on the WMO scale. Since b is always positive (and near 1) and a is always negative and near zero, CO2 is given by this solution of the second-order algebraic Eq. (86):

$$CO2 = \left[-b + \sqrt{b^2 - 4 \cdot a(c - CO2_{ovc})} \right] / (2 \cdot a) \quad (97).$$

To assess the drift in time of the response function from December 2015 to July 2017, we use the concept of virtual tank of fixed (assigned WMO; i.e., CO2, CH4, and CO) mole fractions (Yver Kwok et al., 2015) and compute the raw values (CO2_{ovc}, CH4_{raw}, and p84_{sw}) associated to those mole fractions using the response functions obtained in the calibrations.

We consider a virtual tank with 400 ppm of CO2, 1850 ppb of CH4 and 100 ppb of CO. Moreover, we present here a justification of that procedure and complement it by using the local slope of the response function at the mole fraction of the virtual tank for each species. In the field of high-accuracy atmospheric trace-gas measurements, the calibration fits are used to be generally performed using a limited range in the independent variable that is far from zero (a range around the atmospheric mole fractions of interest). This produces an anticorrelation between the coefficients b and c . The reason is the fact that if b has a positive error (larger slope) then c will have a negative error (smaller Y-intercept) that will increase in absolute value as the distance between the used X-range and zero increases. Therefore, plotting the time series b and c is not the best option for assessing the stability in time of the response function, since part of the variability is due to the anticorrelation and does not correspond with a real variability within the X-range of interest. A more interesting option is to plot the Y-value corresponding to a X-value located within the range of interest instead of c (virtual tank concept) and the local slope at that X-value. Note that for CH4 and CO, which have linear response functions, the local slope does not depend on mole fraction and is equal to the coefficient b .

Figure 44 shows the CRDS raw responses for that virtual tank computed using the response functions obtained in the calibrations. From Figure 44, we obtain the CRDS long-term drift of the raw responses: 0.104 ppm/year for CO2, 2.22 ppb/year for CH4, and 0.544 ppb/year for CO.

As Yver Kwok et al. (2015), we define the fractional variables CH4_{frac}=CH4_{raw}/1850 and CO2_{frac}=CO2_{ovc}/400, i.e., they are as the raw mole fractions of the virtual tank divided by the real mole fractions. Figure 52 shows a scatter plot of CH4_{raw} versus CO2_{ovc} for the virtual tank. When fitting a linear function, the obtained slope is 20.788 ppb/ppm, which is equal to 4.495 when using the fractional variables, CH4_{frac} and CO2_{frac}.

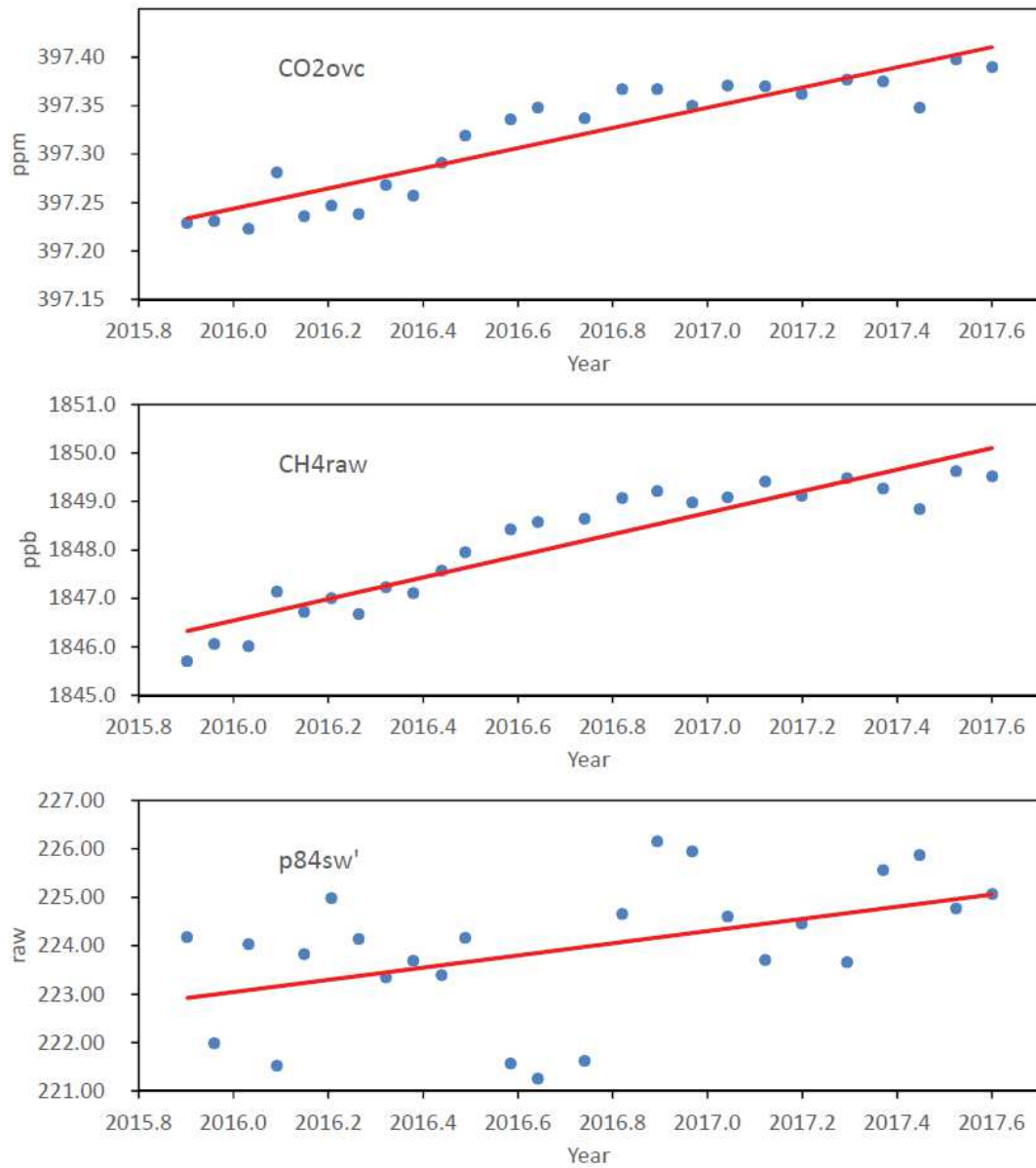

Figure 44: CRDS raw responses (blue dots) for a virtual tank (400 ppm of CO₂, 1850 ppb of CH₄, and 100 ppb of CO) computed using the response functions obtained in the calibrations. Each red line corresponds to a least-square fitting of the data to a linear function.

5

Assuming that those drifts are due to drifts in the real pressure and temperature of the cavity (i.e., drifts in the P and T sensors that, in turn, cause the cavity to be controlled at slightly drifting pressure and/or temperature), and taking into account the fact that the empirical sensitivities (partial derivatives) of the CRDS raw CO₂ and CH₄ with respect to *CP* and

CT are known (Sect. 3.3.6 of Yver Kwok et al., 2015), ~~we have determined that our CRDS has a long-term drift of 0.152°C/Torr and 0.446 Torr/year in the cavity sensors, and~~ using these following general relationships between partial derivatives:

$$\frac{dCH4frac}{dCO2frac} = \left(\frac{\partial CH4frac}{\partial T} \cdot \frac{dT}{dp} + \frac{\partial CH4frac}{\partial p} \right) / \left(\frac{\partial CO2frac}{\partial T} \cdot \frac{dT}{dp} + \frac{\partial CO2frac}{\partial p} \right) \quad (108), \text{ and}$$

$$5 \quad \frac{dCH4frac}{dt} = \left(\frac{\partial CH4frac}{\partial T} \cdot \frac{dT}{dp} + \frac{\partial CH4frac}{\partial p} \right) \frac{dp}{dt} \quad (119);$$

~~where the partial derivatives of the fractional mole fractions with respect to the temperature and pressure have been obtained from Sect. 3.3.6 of Yver Kwok et al. (2015). We have determined that our CRDS has a long-term drift of 0.114 °C/hPa (obtained using Eq. 10 and taking into account that the left-hand side of Eq. 10 is equal to the slope shown in Fig. 5~~

10 ~~multiplied by 400/1850), 0.595 hPa/year (obtained using Eq. 11 and taking into account that the left-hand side of Eq. 11 is equal to the slope shown in Fig. 4b divided by 1850), and 0.0678 °C/year (obtained multiplying the two former numbers) in the cavity sensors.~~ Note that the use of Eqs. (108) and (119), which provide a quantitative estimation of the drift in temperature and pressure, is a novelty introduced in the present paper. ~~The fact that the drifts in temperature and pressure are linear in time is a consequence of the fact that the slopes shown in Fig. 5, Fig. 4b and Fig. 4a are constant, and from Eqs. (10) and (11).~~

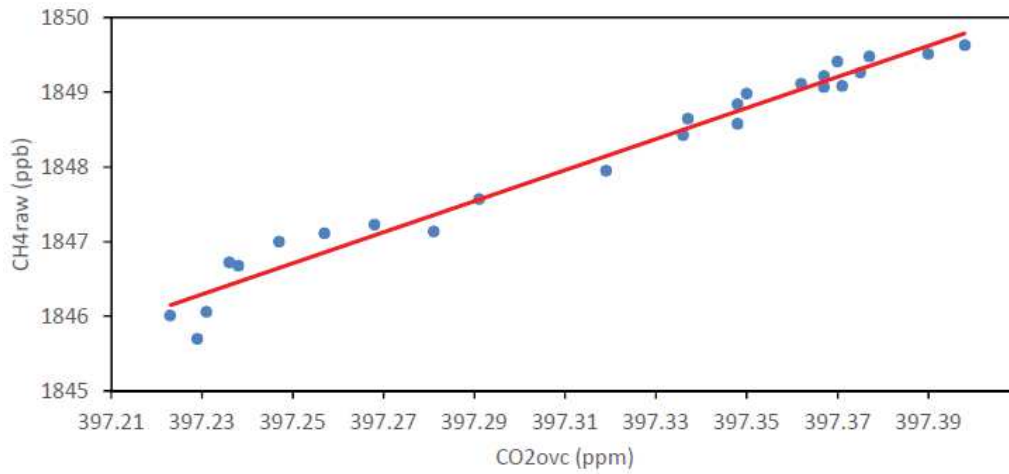

15 **Figure 52:** Scatter plot of CH4raw versus CO2raw for the mentioned virtual tank. The red line has been obtained performing a least-square fitting of the data to a linear function.

Figure 63 provides additional information about the response functions determined in the calibration. In detail, Fig. 63 provides for each species the local slope of the response function at the mole fraction of the virtual tank, as well as the quadratic coefficient (*a*) for the CO2 response function.

20

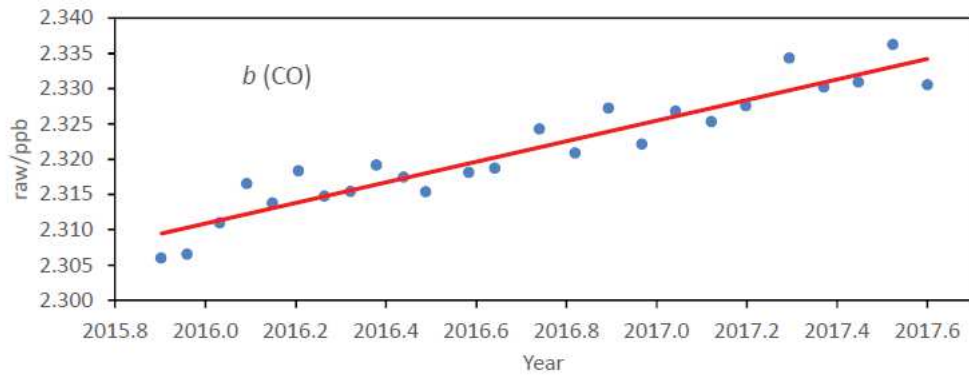
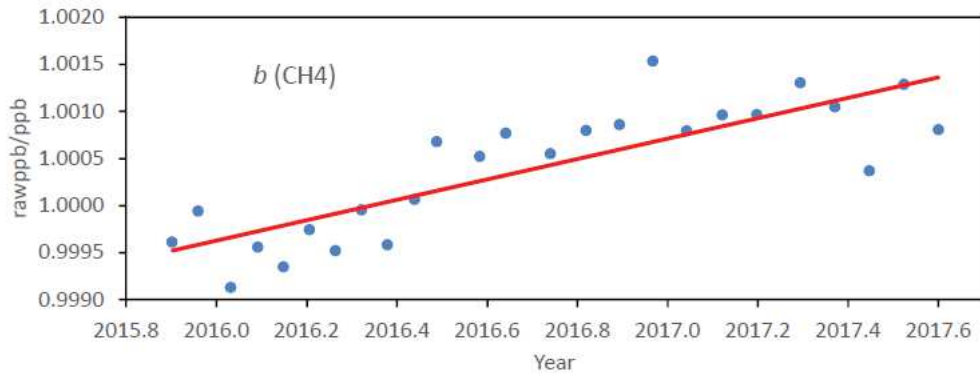
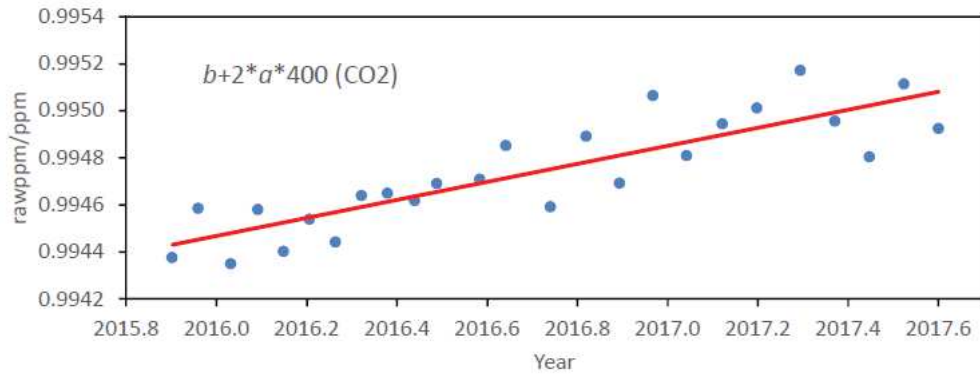
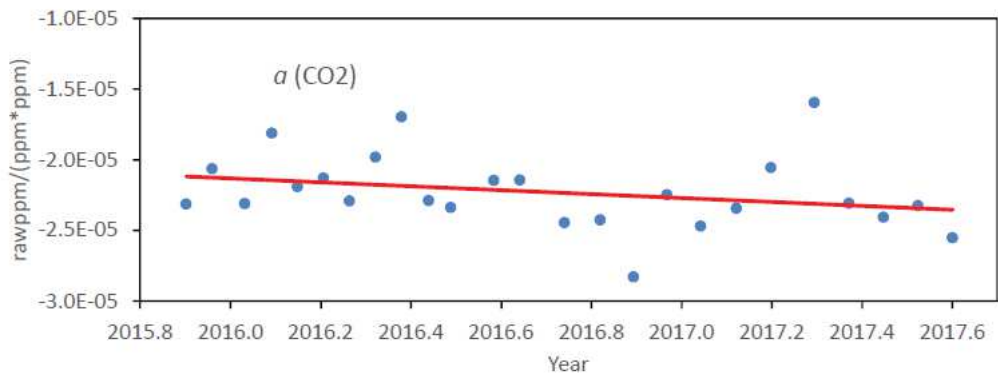
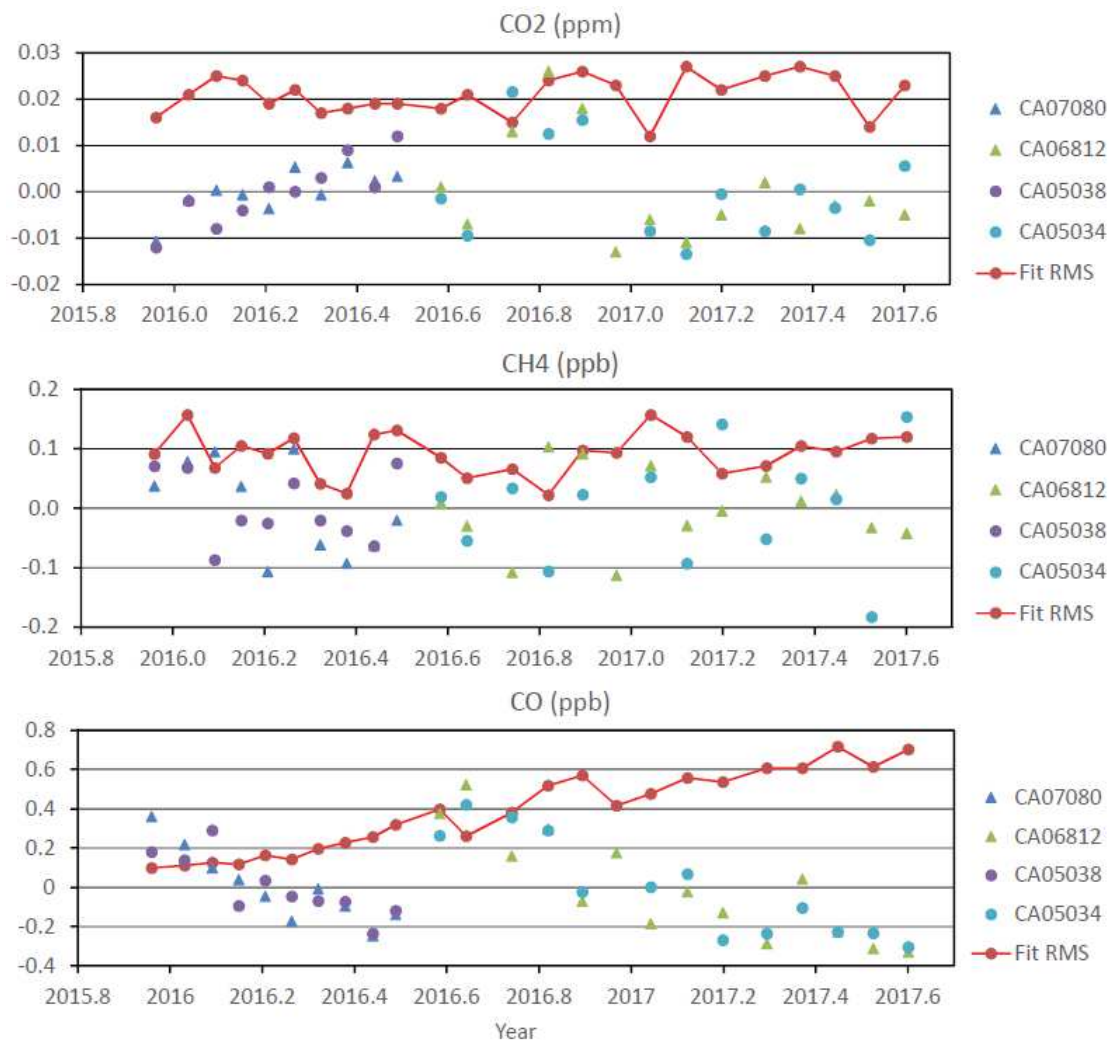

Figure 63: Quadratic coefficient of the CO₂ response function (a) and local slope of the response function at the mole fraction of the virtual tank, for CO₂, CH₄ and CO. Note that for CH₄ and CO, the local slope does not depend on mole fraction and is equal to the coefficient b . The red line corresponds to a least-square fitting of the data to a linear function.

Figure 74 provides for each species and calibration the RMS residual of the fit and the difference between the assigned mole fraction to a target gas and the mean mole fraction of such target gas. For CO₂, the mean RMS residual for all the calibrations is 0.021 ppm, there is no trend in the associated time series, and the maximum departure in absolute value of a target gas assignment from the mean for such target gas is 0.026 ppm. Those numbers are quite small compared with the GAW DQO for CO₂, and indicate a good performance of the measurement system for CO₂. For CH₄, the mean RMS residual for all the calibrations is 0.09 ppb, there is no trend in the associated time series, and the maximum departure in absolute value of a target gas assignment from the mean for such target gas is 0.18 ppb. As for CO₂, those numbers are quite small compared with the GAW DQO for CH₄ and indicate a good performance of the measurement system for CH₄. However, for CO, there is a significant trend in the time series of RMS residuals, which had a value of around 0.1 ppb for the first calibrations whereas it was around 0.7 ppb for the last ones. Moreover, there are significant downward drifts in all the time series of target gas assignments, which is a very strange fact since CO standards use to drift upward (*i.e.*, when a CO standard drifts, this drift is generally positive; e.g., https://www.esrl.noaa.gov/gmd/cc1/co_scale.html). All these facts suggest that the IZO CRDS CO WMO tertiary standards might be drifting upward quite significantly at different rates. In Sect. 7, this possibility is investigated.



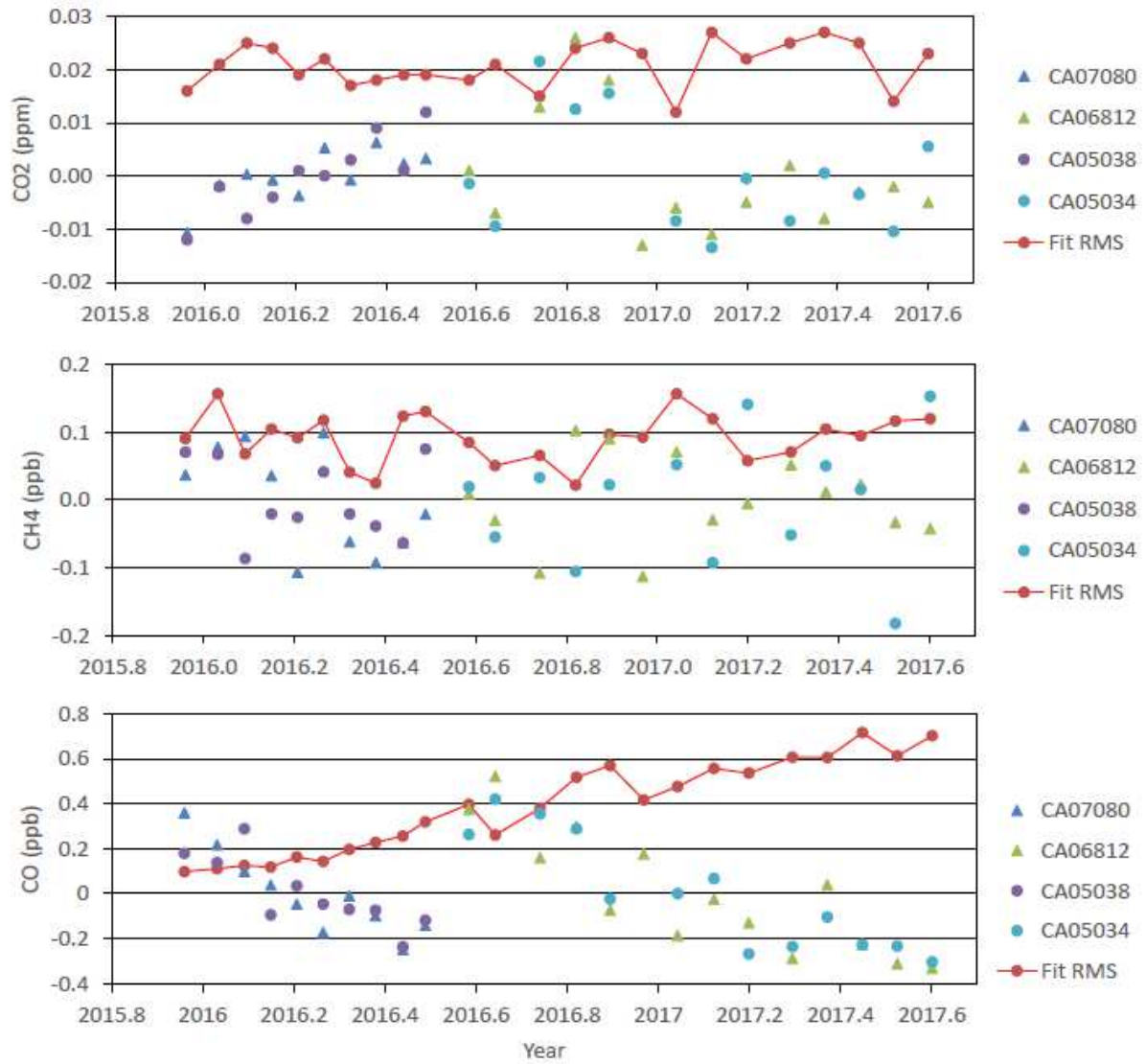

Figure 74: RMS residual of the fit (red dots/line), and difference between the assigned mole fraction to a target gas and the mean mole fraction of such target gas (a different colour is used for each target gas), for each species and calibration mole-fraction calibration performed using 4 WMO laboratory standards (every 3 or 4 weeks).

5 5 Water Vapour Correction: water droplet method

The natural air contained in the WMO tertiary standards and the target standards is dry. However, ambient air contains water vapour and if it is not completely dried before measurements (as it is done in NDIRs), the dilution and pressure broadening

effects due to H₂O need to be taken into account and corrected (Chen et al., 2010; Zellweger et al., 2012; Rella et al., 2013, Chen et al., 2013; Karion et al., 2013).

For determining the particular water vapour dilution and pressure broadening corrections for the IZO CRDS G2041, we performed a long water droplet test (around 12 hours) using crushed (to increase the surface/volume ratio) Silica Gel balls soaked with deionized water contained in a stainless steel filter housing (called MPI/NOAA implementation in Rella et al., 2013), as Fig. 85 shows. The dry natural air coming from a standard flowed continuously during around 12 hours through the wet Silica Gel before being measured in the CRDS. Figure 96 shows the evolution in time of the h₂o_reported (*hr*) in pph (parts per hundred in mole fraction; i.e., centimoles per mole of air) determined by the CRDS.

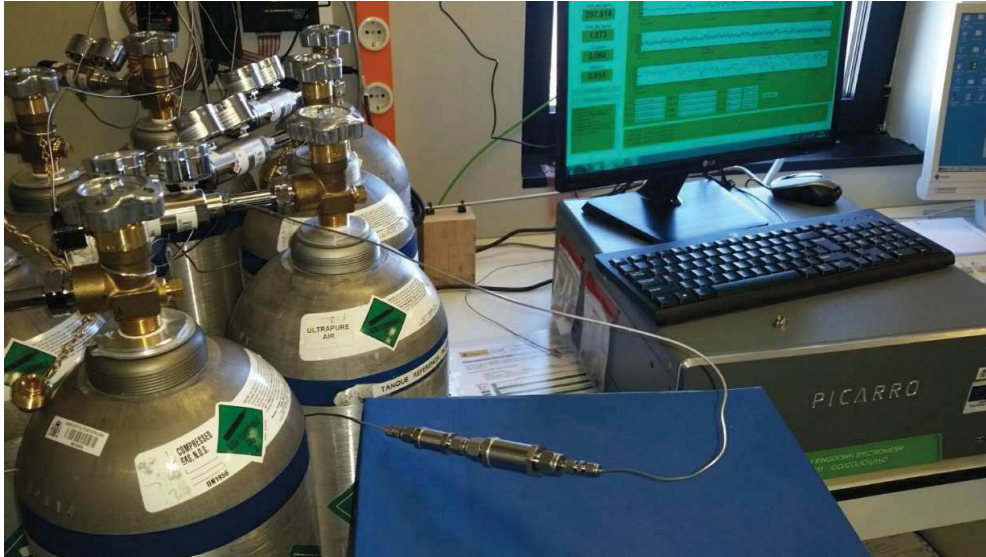

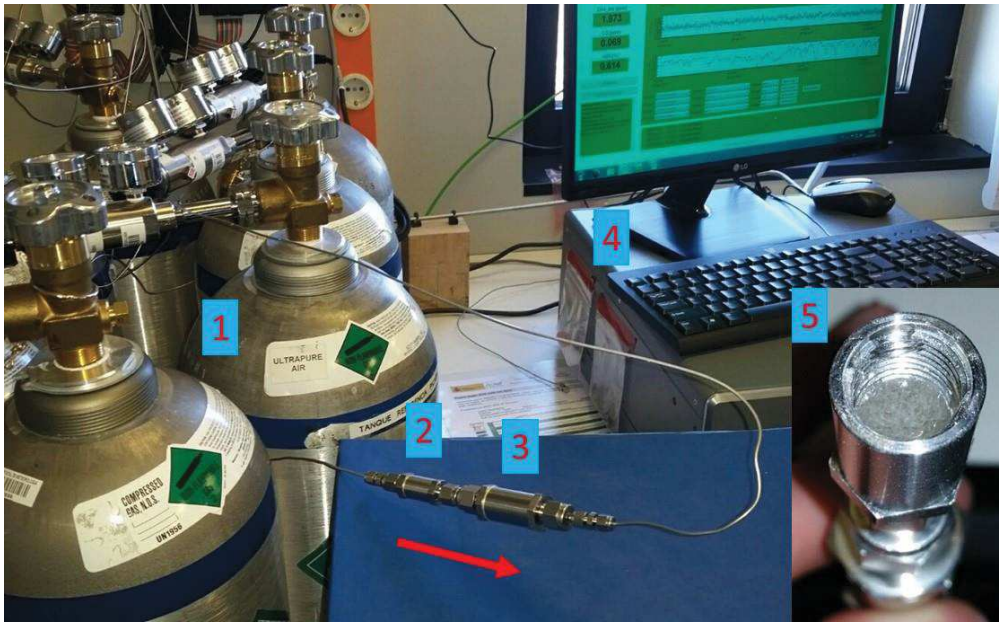
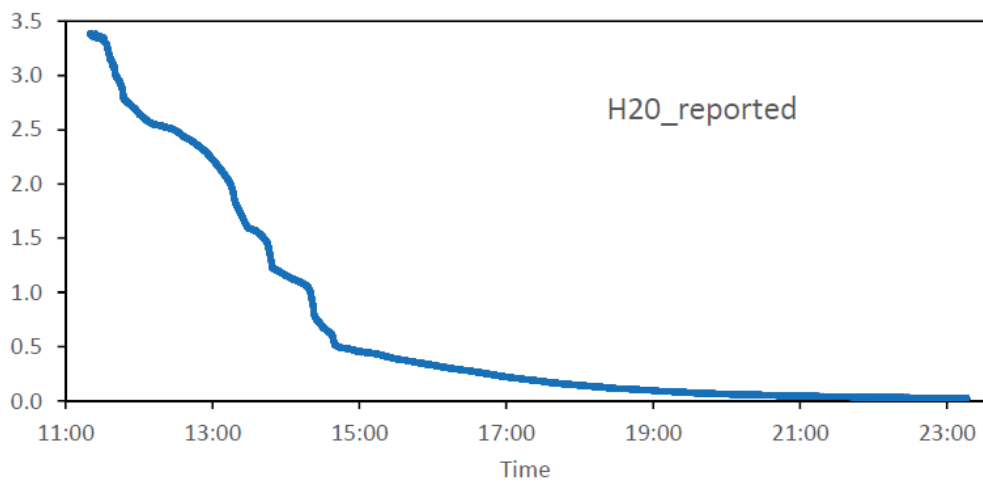

Figure 85: Experimental setup used for the water droplet test performed to the IZO CRDS G2401. 1) Cylinders containing dry natural air (the red arrow shows the flow direction); 2) stainless steel filter housing containing crushed Silica Gel balls (see details of the interior in 5) soaked with deionized water; 3) stainless steel 0.5- μm filter; and 4) CRDS.

5



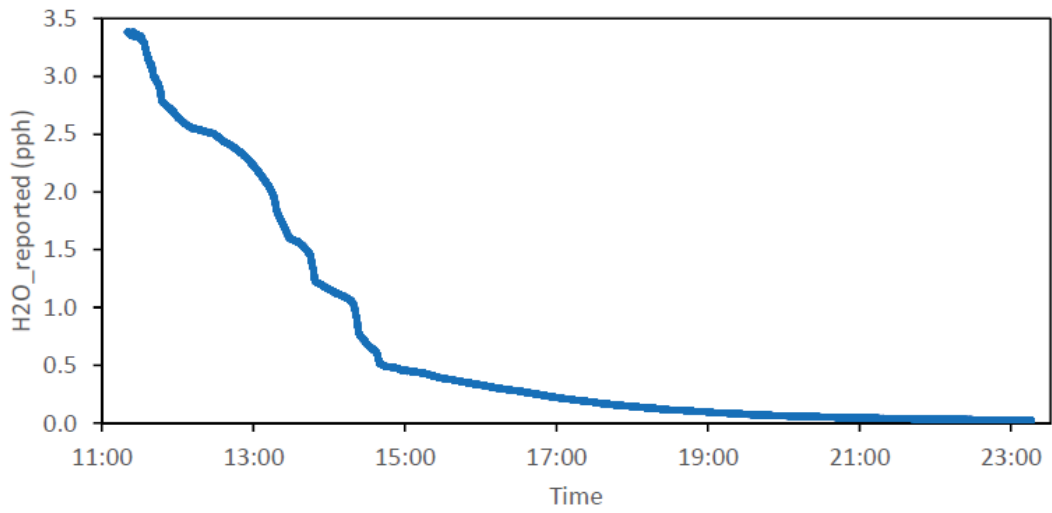

Figure 96: Evolution in time of the h2o_reported (pph) determined by the CRDS.

For CO₂ and CH₄, we use these empirical correction equations for the H₂O dilution and pressure broadening effects (Chen et al., 2010):

$$CO2ovc_{wet} = CO2ovc_{dry} \cdot (1 + d \cdot hr + e \cdot hr^2) \quad (1240),$$

$$CH4raw_{wet} = CH4raw_{dry} \cdot (1 + d \cdot hr + e \cdot hr^2) \quad (1344),$$

where CO₂ovc_{dry}, CH₄raw_{dry}, *d* and *e* (different in each equation) are determined by least-square fitting to test results. Since the experiment is very long, before performing the least-square fit, we aggregate data computing 100-data means. That corresponds approximately to a 59-second mean, since there are 1.7 data per second. For CO₂, we obtained coefficients *d* and *e* very close to those reported by Chen et al. (2010). Thus, we decided to use their coefficients, *d* = -0.012 pph⁻¹ and *e* = -0.000267 pph⁻². Figure 107 shows CH₄raw versus *hr* during the experiment and the least-square fitted curve, being the coefficients obtained for CH₄ being: *d* = -0.009974 pph⁻¹ and *e* = -0.0001757 pph⁻².

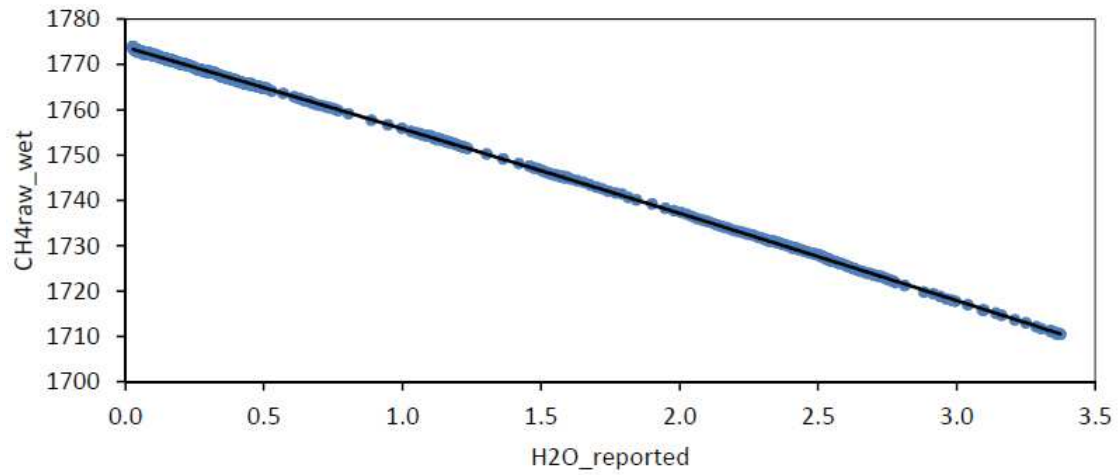

Figure 107: CH4raw versus hr during the water droplet experiment (in blue) and the least-square fitted curve (in black).

For CO, we rely on the H2O dilution and pressure broadening correction determined by Rella (2010), as other authors have done (Chen et al., 2013; Laurent, private communication), and determine an improvement in the correction for the CO peak interference (zero error or spectral-baseline correction) due to the nearby H2O peak, respect to the factory values. To this end, we use a simple and accurate novel method. We consider the equation:

$$p84sw' + A \cdot bh + B \cdot bh^2 + C \cdot bh^3 = p84sd' \cdot (1 + d \cdot bh + e \cdot bh^2) \quad (1412),$$

which is equivalent to Eqs. (1210) and (1311) except for the cubic polynomial on the left-hand side that accounts for the mentioned CO spectral-baseline correction. We advance that the novelty is not in the cubic correction (Chen et al., 2013; and Karion et al., 2013, used a quartic correction), but in the method described below. We use $d = -0.01287$ and $e = -0.0005365$ (Rella, 2010), and $p84sd'$, A , B , and C are determined by least-square fitting of the experimental data to the cubic equation:

$$p84sw' = p84sd' + (d \cdot p84sd' - A) \cdot bh + (e \cdot p84sd' - B) \cdot bh^2 - C \cdot bh^3 \quad (153),$$

obtained rearranging Eq. (142). The instantaneous CRDS CO signal is quite noisy, but the noise is significantly reduced by using 4000-data running means (39.2-minute approximately) without compromising the accuracy of the data due to the long duration of the experiment. Note that least-square fits are very sensitive to outliers, and the fit will be more accurate if the 4000-data running mean is performed previously (using a 39-minute running mean instead of a 1-minute running mean, the random noise is reduced by a factor 6, approximately). As far as the authors know, this is a novel method not done before. It is important to have a very accurate H2O correction, since in spite of the fact the instantaneous CRDS CO values are quite noisy, such noise decreases significantly when performing successively 30-second, 1-hour, 12-hour means, whereas the hypothetical error in the H2O correction remains constant behaving as a bias. After performing the 4000-data running means, we aggregate data computing 100-data means as for CO2 and CH4. Figure 118 shows $p84sw'$ versus bh during the experiment and the least-square fitted curve corresponding to Eq. (153). After determining the coefficients of that cubic polynomial, we solve for the unknown constants in Eq. (142): $A = -5.287565 \text{ raw/pph}^{-1}$, $B = 5.283987 \text{ raw/pph}^{-2}$, and $C = -$

1.120169 raw/pph⁻³. The absolute value of A is much smaller than $1000*|w1|$, which appears in Eq. (53). This means A is indeed a relatively small correction. On the contrary, B and C are very significant corrections comparing with their respective terms in Eq. (53), in which there is not cubic term. Figure 11 also shows the difference between the raw CO provided by the CRDS and the CO processed in the way described in this article (including H2O correction and calibration), both after performing a 4000-data running mean. The difference of (approx.) -3.5 ppb at the intercept is due to the calibration (COraw is not calibrated), whereas the “sinusoidal” behaviour in bh is due to the different spectral-baseline correction, which in the first variable is generic whereas in the second variable is specific for our CRDS unit.

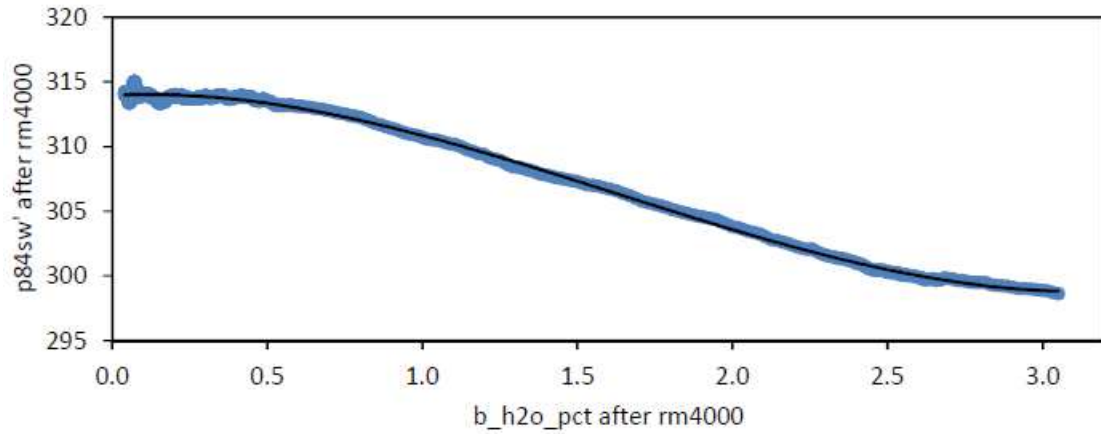

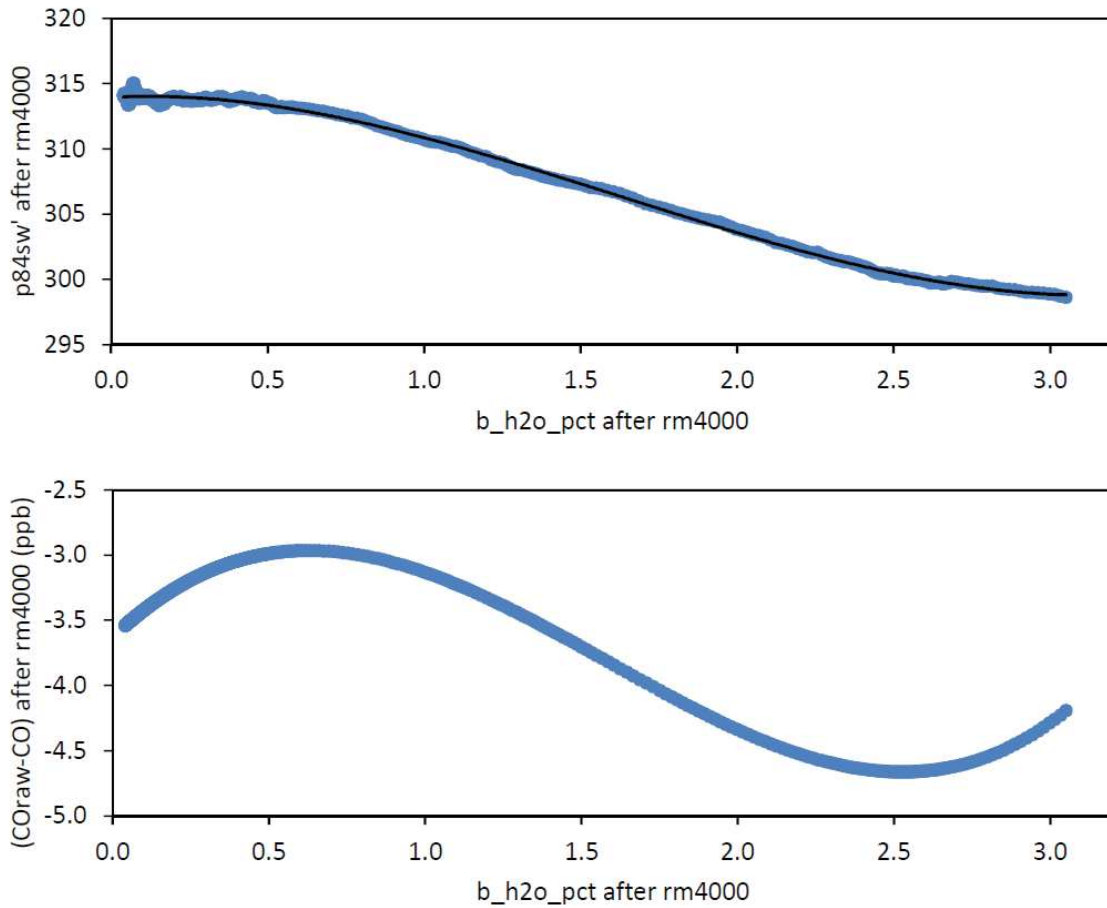

Figure 118: **Upper plot:** $p84sw'$ versus bh during the water droplet experiment (blue dots), both after performing a 4000-data running mean, and the least-square fitted curve corresponding to Eq. (1543) in black. **Lower plot:** difference between the raw CO provided by the CRDS and the CO processed in the way described in this article (including H₂O correction and calibration), both after performing a 4000-data running mean.

5

6 Ambient Measurements

Figure 129 shows the ambient air/gas standard plumbing configuration operative since 28 November 2016. Before that date, there were no “Dedicated inlet”, no drying (no cooled flasks), no solenoid nor needle valves, and ambient air entered through the MPV. Operative ambient air measurements started on 27 November 2015. Target gas measurements started on 18 December 2015 with a 7-hour cycle (3 hours of ambient, 30 minutes of target 1, 3 hours of ambient, and 30 minutes of target 2) to monitor better the behaviour of the CRDS, which became a 21-hour cycle after 24 June 2016. With the new plumbing configuration, ambient air is alternatively sampled from the two inlet lines within the 21-hour cycle (15 hours of ambient

10

from the dedicated inlet and 5 hours of ambient from the general inlet). This has two purposes: 1) to provide a lot of time to exchange the flask used to trap H₂O in the air line not used at this moment; 2) to check the consistence between both lines after every switch: a bias between them might indicate the existence of a leak in one of the lines (e.g., in the general inlet, which has a few large unions and several instruments connected to it; or at the flasks connections). Since the cooler bath temperature is -40 °C, there is no complete drying. Therefore, it has been necessary to apply the H₂O water vapour correction for the full measurement period.

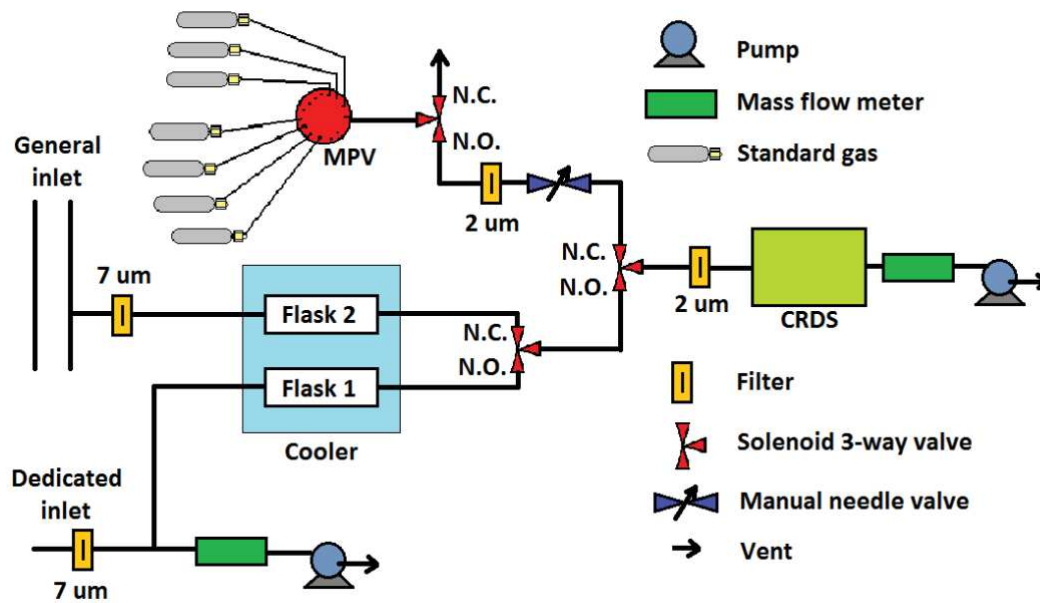

Figure 129: Ambient air/gas standard plumbing configuration operative since 28 Nov 2016.

6.1 Ambient Air Measurement Processing

After performing the pre-processing detailed in Sect. 3, we apply an additional filtering to the 30-second means. We retain~~For not discarding~~ a pre-processed 30-second mean if the following conditions are met: 1) the mean values of the following variables need to be within the indicated ranges: *CP*: 186.7 ± 0.047 hPa (140 ± 0.035 Torr), *CT*: 45 ± 0.02 °C, and *OV*: 20000-40000; 2) it needs to exist a calibration before and after the ambient mean considered, separated in time less than 180 days between them, as in ICOS (Hazan et al., 2016).

Then, we apply the following processing scheme. Firstly, we apply water vapour correction: a) using Eqs. (129) and (134) we compute *CO₂ovc_dry* and *CH₄raw_dry* from *CO₂ovc_wet*, *CH₄raw_wet* and *hr* (i.e., dilution and pressure broadening effect correction); b) using Eq. (142) we compute *p84sd'* from *p84sw'* and *bh* (i.e., refinement of the interference correction as well as dilution and pressure broadening effect correction). Secondly, we apply the calibration curves interpolated linearly

in time: a) for CO₂, we employ Eq. (97) using CO₂ovc_dry where it says CO₂ovc; b) for CH₄, we employ Eq. (64) using CH₄raw_dry where it says CH₄raw; and c) for CO, we employ Eq. (75) using p84sd' where it says p84sw'. Finally, we proceed to discard data due to the stabilization time after any sample path switch: 10 minutes for ambient measurements, and 20 minutes for target and calibration gas injections.

- 5 Figure 13 shows implicitly the H₂O corrections applied to CO₂ (dCO₂_H₂O), CH₄ (dCH₄_H₂O) and CO (dCO_H₂O) in physical units for ambient air measurements at IZO, e.g., dCO₂_H₂O is equal to (CO₂ovc_dry – CO₂ovc_wet) divided by the local slope of the calibration curve (Eq. 8). The plots for CO₂ and CH₄ are curves. However, the plot for CO shows a cloud of dots because Eq. (14) is more complex and there does not exist a bijection between the X and Y variables.

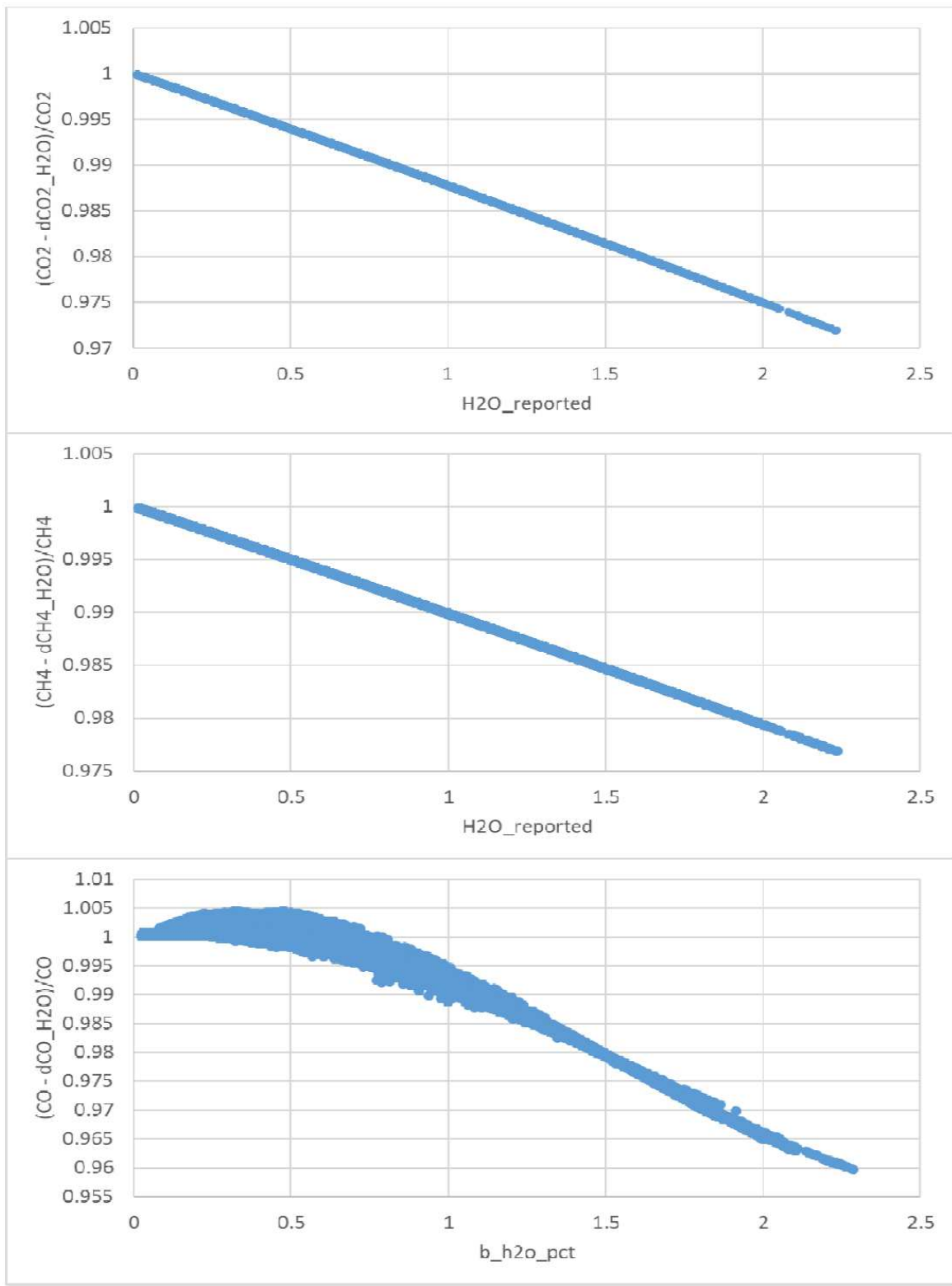

Figure 13. Indirect plots of the H₂O corrections applied to CO₂ (dCO₂ H₂O), CH₄ (dCH₄ H₂O) and CO (dCO H₂O) in physical units for ambient air measurements at IZO, e.g., dCO₂ H₂O is equal to (CO₂ovc_{dry} – CO₂ovc_{wet}) divided by the local slope of the calibration curve (Eq. 8).

- 5 After the date in which the cold bath was implemented (-40 °C), the applied H₂O corrections for ambient air measurements have been quite small: 1) for CO₂, the mean correction has been 0.10 ppm (maximum: 0.36 ppm, minimum: 0.09 ppm; both for 10-minute means); 2) for CH₄, the mean correction has been 0.38 ppb (maximum: 1.39 ppb, minimum: 0.34 ppb; both for 10-minute means); and 3) for CO, the mean correction has been -0.03 ppb (maximum in absolute value: -0.07 ppb, minimum in absolute value: -0.01 ppb; both for 10-minute means). Since those corrections are quite small, for this period
- 10 relying on the generic factory H₂O corrections would have been right.

6.2 Target Gas Injections

- Table ~~63~~ summarizes the statistics for the target gas injections (30-second-mean assignments), whereas Fig. ~~140~~ shows the time series of mole fraction assignments for one of the target gases. The results are good. Note that 30-second is a too short time for CO, and it is necessary to consider longer averages for reducing noise. The ambient processing scheme described in
- 15 Sect. 6.1 is also used to assign mole fractions to the target and calibration gas injections, and it is checked that the water vapour correction for them is smaller than 0.01 ppm for CO₂, and 0.1 ppb for CH₄ and CO.

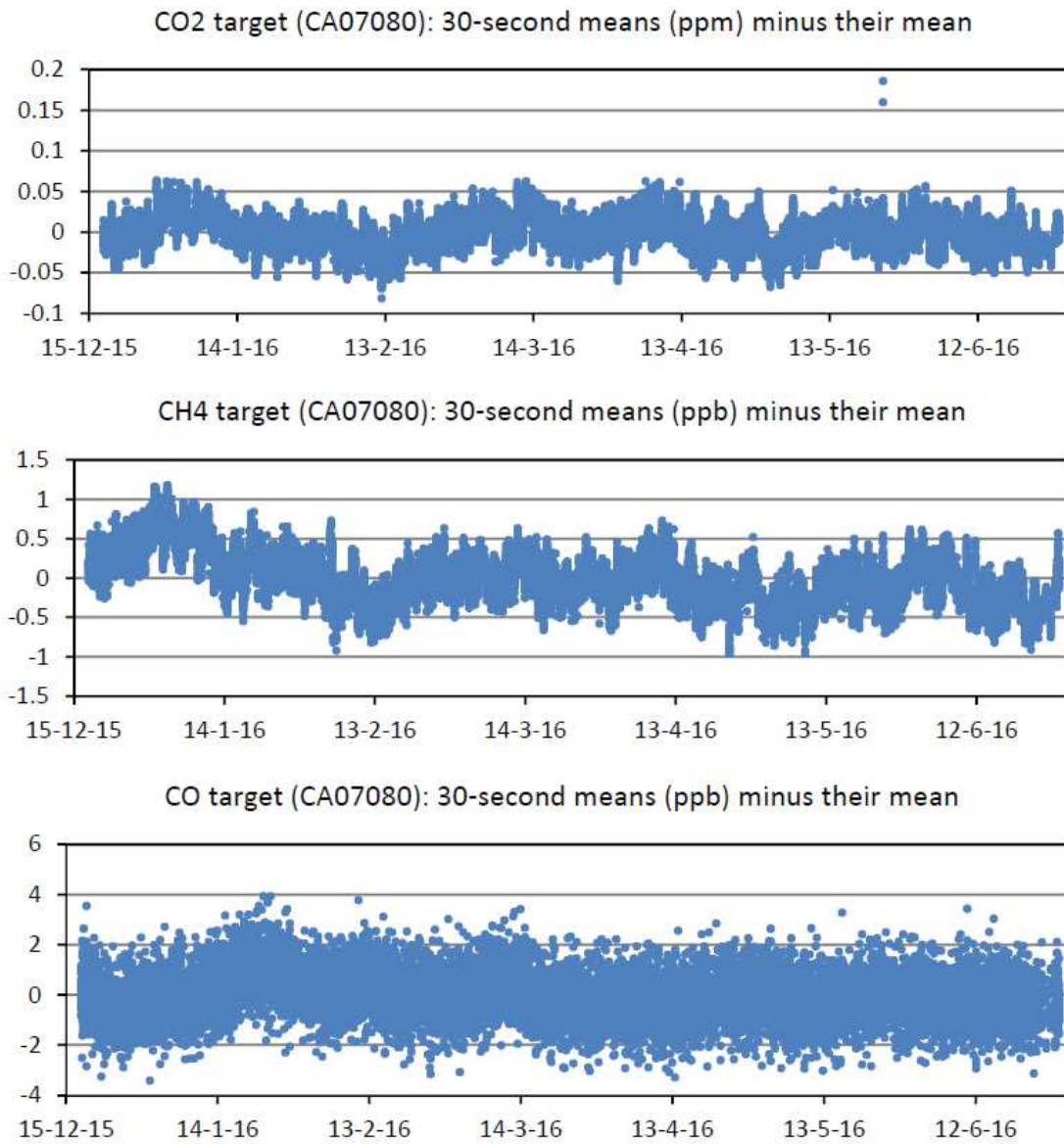

Figure 140: Time series of mole fraction assignments for one of the target gases.

Tank/months	CO2 (ppm)	Std.dev.	CH4 (ppb)	Std.dev.	CO (ppb)	Std.dev.
CA07080/ 7m	381.96	0.020	1825.43	0.32	148.60	0.97
CA05038/ 7m	368.85	0.020	1777.04	0.33	93.56	0.99
CA06812/ 13m	372.48	0.020	1784.80	0.27	142.04	1.01
CA05034/ 13m	363.71	0.020	1775.89	0.27	139.11	0.98

Table 63. Statistics for the target gas injections (30-second-mean assignments): mean and standard deviation (Std.dev.) for the different species.

6.3 Comparison with other continuous measurements carried out at Izaña

5 In this subsection, we compare the CRDS IZO ambient daily-nighttime (from 20:00 UTC of the previous day till 8:00 of the considered day) means with the co-located hourly means from the IZO Li7000 NDIR for CO₂ (Gomez-Pelaez et al., 2011; Gomez-Pelaez et al., 2014; Gomez-Pelaez et al., 2016), IZO Varian GC-FID for CH₄ (Gomez-Pelaez et al., 2011; Gomez-Pelaez et al., 2012; Gomez-Pelaez et al., 2016), and IZO RGA-3 GC-RGD for CO (Gomez-Pelaez et al., 2013; Gomez-Pelaez et al., 2016), all of them in the scales already indicated in Sect. 4. We use daily-nighttime means for the comparison

10 because: 1) as mentioned in the introduction, IZO has background conditions during nighttime; and 2) when using 12-hour averages, we improve the signal to noise ratio and remove any hypothetical dependence on the used IZO general inlet due to small inhomogeneities in space and time of the mole fraction fields ~~in space~~. Note that the data for 2017 are still not final. Figure 154 shows the time series of daily-nighttime CRDS measurements, whereas Table 74 shows the monthly-mean differences between the daily-nighttime CRDS measurements and those for the rest of the mentioned IZO instruments. As

15 Table 74 shows, for CO₂ and CH₄ the differences between the instruments are within the GAW compatibility objectives (0.1 ppm for CO₂ and 2 ppb for CH₄), except for 4 months for the former and 3 months for the later (coincident with those for CO₂). The larger differences took place in October and November 2016. We think they were produced by a small leak in the general inlet used by the CRDS (the NDIR and the GC-FID used another general inlet). However, for CO the difference between the instruments is larger than 2 ppb after March 2016. The WMO tertiary standards used in the RGA-3 have been

20 calibrated two times by the WMO CCL and the inferred drifts were considered significant, extrapolated forward in time, and taken into account in the RGA-3 data processing. These results seem to support the hypothesis that the observed negative differences are explained by the fact that the CRDS laboratory standards (WMO tertiaries) might be drifting up significantly for CO (see Sect. 4). ~~Maybe, there could be also a small contribution from WMO CO Primaries of the X2014A scale drifting less than initially computed by CCL, which is a recent suspicion of the CCL that needs to be checked during the next two~~

25 ~~years (Crotwell, communication during GGMT 2017).~~

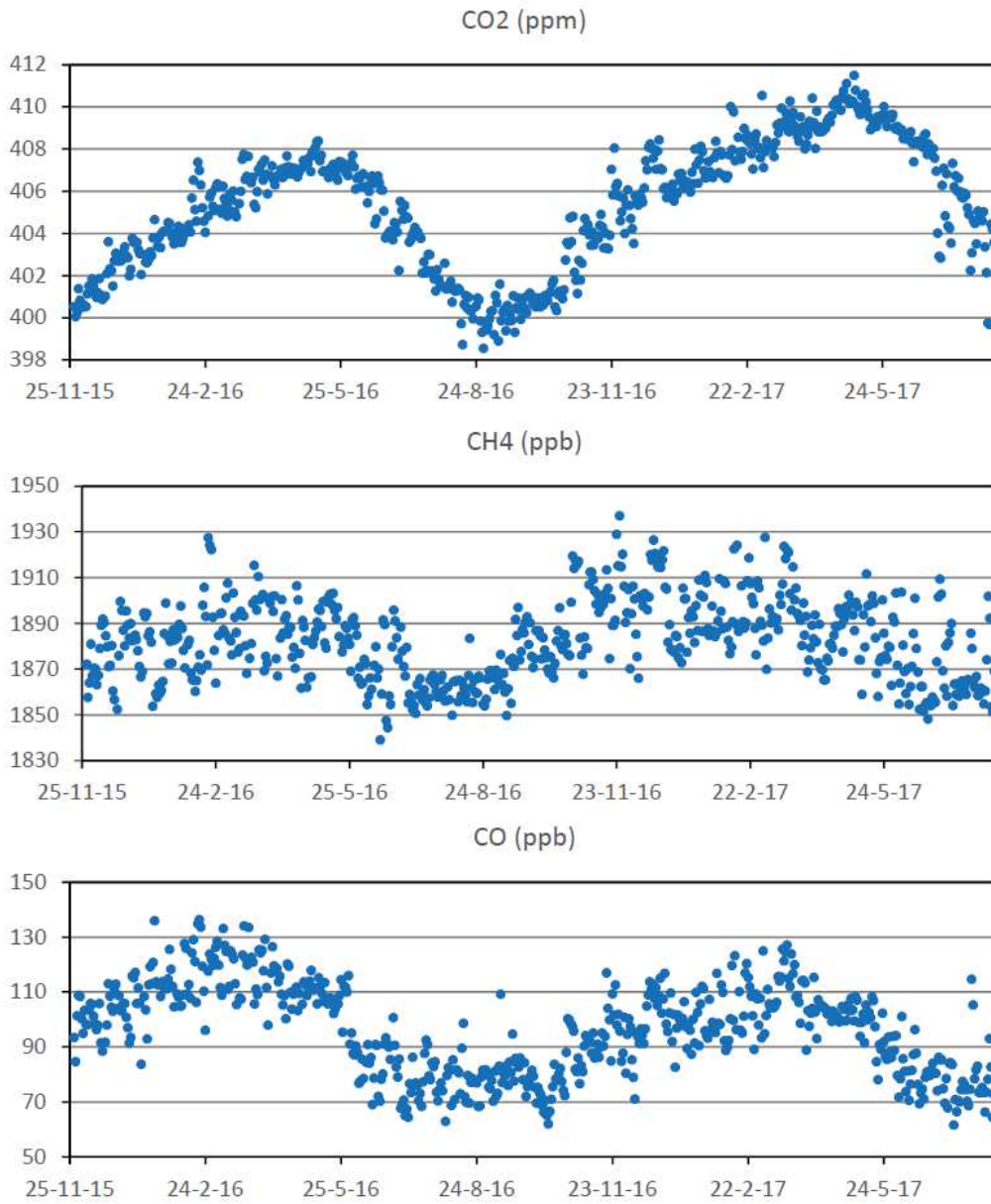

Figure 154: Time series of daily-nighttime (12-hour averages) CRDS measurements (CO₂, CH₄ and CO).

Year	Month	CO ₂ CRDS - CO ₂ Li7000 (ppm)	CH ₄ CRDS - CH ₄ VarianFID (ppb)	CO CRDS - CO RGA3 (ppb)
Full2015	period2017	-0.07	1.2	-2.8
2015	11	-0.08	1.6	-0.4

2015	12	-0.04	0.9	-1.1
2016	1	-0.03	1.0	-1.3
2016	2	-0.08	1.0	-1.8
2016	3	-0.07	0.3	-2.4
2016	4	-0.06	-0.1	-2.7
2016	5	-0.02	0.2	-2.9
2016	6	-0.03	0.9	-3.0
2016	7	0.00	1.1	-3.2
2016	8	0.05	1.9	-2.9
2016	9	-0.10	2.0	-3.1
2016	10	-0.12	3.3	-4.1
2016	11	-0.15	3.1	-3.0
2016	12	-0.07	0.5	-3.7
2017	1	-0.09	1.1	-3.0
2017	2	-0.14	2.1	-3.3
2017	3	-0.11	0.5	-3.6
2017	4	-0.08	0.4	-2.7
2017	5	---	0.3	-3.4

Table 74: Monthly-mean differences between the daily-nighttime CRDS measurements and those for the rest of the mentioned IZO instruments (Li7000 NDIR for CO₂, Varian GC-FID for CH₄, and RGA-3 GC-RGD for CO).

7 Preliminary independent assessment on the drift rates of the CRDS CO standards

- 5 Some few facts presented in Sect. 4 and Sect 6.3 seem to indicate the CRDS CO WMO tertiary standards might be drifting significantly. These standards have been calibrated only once by CCL: in August-September 2015. In order to perform a preliminary independent assessment on the drift rates of the CRDS CO standards, we have proceeded as follows. As mentioned in Sect 6.3, the WMO tertiary standards used in the RGA-3 have been calibrated twice (9 years distant) by the WMO CO CCL and the inferred drifts were considered significant and extrapolated forward in time. We have performed a 4-
- 10 cycle calibration in the CRDS ~~tofer~~ comparing the CRDS standards (CB11240, CB11389, CB11393, and CB11340) and the RGA-3 standards (CA06968, CA06768, CA06988, CA06946, and CA06978). The first step has been assigning CO₂ and CH₄ mole fractions to the RGA-3 standards using the calibration curves obtained using the CRDS standards. The second step has been assigning CO mole fractions to the CRDS standards using the calibration curve obtained using the RGA-3 standards, whose fit RMS residual is 0.4 ppb. In the third step, we determined the drift rate of each CRDS standards using

the CCL assignment done in 2015 and the present assignment (done on 4 October 2017), which is indirectly traceable to the WMO primaries. The standard CB11240 is the only one with a significant drift rate, 1.21 ppb/year, having 195.87 ppb at present. The other three standards have all positive drift rates, being the maximum 0.17 ppb/year. We have performed the exercise of reprocessing all the CRDS calibrations taking into account the drift rates determined for the four CRDS standards (even those not statistically significant), as shown in Fig. 162. Comparing Fig. 162 with Fig. 74c, we see now there is no trend in the RMS residual from the calibration fit and the downward drift of the target gases is significantly smaller. However, when reprocessing the CRDS ambient CO time series, the maximum improvement in the CRDS minus RGA-3 monthly difference time series is 0.3 ppb for some periods, remaining unchanged the global mean difference for the full period. Therefore, we infer the performance of the calibrations improves largely when taking into account the quite significant drift in the standard CB11240, but the CRDS versus RGA-3 ambient differences remain almost unchanged. Perhaps, a possible explanation might be in the problems detected recently by the CCL in the CO WMO-X2014A scale (https://www.esrl.noaa.gov/gmd/ccl/co_scale_update.html).

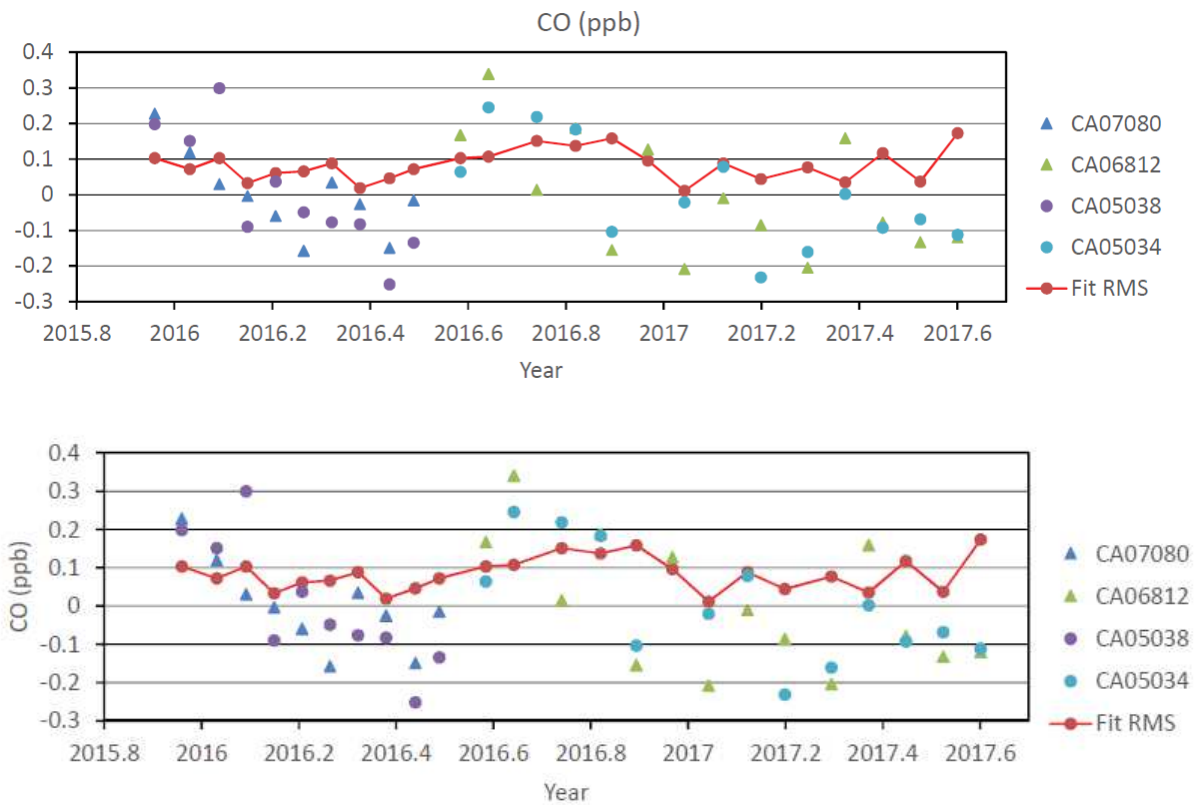

Figure 162: RMS residual of the fit (red dots/line), and difference between the assigned mole fraction to a target gas and the mean mole fraction of such target gas (a different colour is used for each target gas), for each species and calibration mole-fraction

calibration performed using 4 WMO laboratory standards (every 3 or 4 weeks), after taking into account the drift rates of the CRDS standards.

8 Summary and Conclusions

- At the end of 2015, a CO₂/CH₄/CO CRDS was installed at the Izaña Global GAW station to improve the Izaña GHG GAW measurement programme and guarantee its long-term maintenance. The results of the CRDS acceptance tests were good. However, a correction for CO₂ that takes into account the inlet pressure had to be incorporated in order to achieve a RMS residual of around 0.02 ppm, which is the value we obtain with the IZO NDIR based measurements systems. For CO, our data processing is based on the raw spectral peak data instead of on the raw CO provided by the instrument. The relationships between flow rate, CRDS inlet pressure and CRDS outlet valve aperture have been determined also. The CRDS inlet pressure sensitivity is determined for the different compounds as well as its stability over the years.
- We use linear response functions for CH₄ and CO, and a quadratic response function for CO₂. The CRDS long-term drift of the raw responses is: 0.104 ppm/year for CO₂, 2.22 ppb/year for CH₄, and 0.544 ppb/year for CO. Assuming that those drifts are due to drifts in the real pressure and temperature of the cavity, we have determined that our CRDS has a long-term drift of 0.0678152 °C/year Torr and 0.595446 Torr/hPa/year in the cavity sensors using relations between partial derivatives. We show also the evolution in time of the response-function local slopes at the mole fractions of the virtual tank, as well as the RMS residual in the calibration fits, which has no significant trend except for CO.
- The time series of target gas assignments during calibrations are also shown, which again indicate a good behaviour for CO₂ and CH₄, but a downward drift for CO. Those facts seem to point out the CRDS CO WMO tertiary standards are probably drifting significantly in spite of the fact they have been only used during two years. Using an independent set of CO laboratory standards whose drift rates have been determined by the CO CCL, we conclude that one of the CRDS standards is drifting quite significantly (1.21 ppb/year). The performance in the calibrations improves when taking that drift into account.
- The results of the long water-droplet test (12 hours) have been presented and used for the H₂O water vapor correction. The determination of the H₂O correction for CO presents two novelties: use of the raw spectral peak data and use of a running mean to smooth random noise before performing the least square fit.
- We have presented the ambient measurement scheme and its data processing. Target gas injections show very small standard deviations except for CO. The agreement with other IZO in situ continuous measurements is good most of the time for CO₂ and CH₄, but for CO is just outside the GAW 2-ppb objective. It seems the disagreement is not produced by the drifts in the CRDS CO WMO tertiary standards. The mean differences for the full period are: -0.07 ppm for CO₂, 1.2 ppb for CH₄, and -2.8 ppb for CO.

- We have physically determined and discussed the origin of the inlet pressure and H₂O dependences of the CRDS flow, and pointed out the existence of flow-rate-dependent small spatial inhomogeneities in the pressure and temperature fields inside the cavity. We have shown that the slightly-depleted-in-pressure regions inside the CRDS cavity in the neighbourhood of the inlet and outlet pipes due to the cross-section change, are probably the cause of the slight CO₂ correction associated to the mass flow rate we have empirically obtained. We suggest performing a gas dynamic numerical simulation of the pressure and temperature fields inside the CRDS cavity for different flow rates. This could help to improve the spectral forward model used by the CRDS and also to take into account more accurately the impact of the flow rate on the measurements. On the other hand, the use of conical adapters for connecting the pipes to the CRDS cavity might keep the pressure gradients associated to the cross-section changes out of the laser path.

Code availability. The Fortran 90 codes developed in this work could be made available to other researchers under a cooperative agreement with the Izaña Atmospheric Research Centre (AEMET). However, a very limited support on their use could be provided.

- 15 **Data availability.** The data presented in this paper is available under request. If the supplied data is intended to be used in a scientific article, co-authorship should be offered to data providers.

Appendix A. A note concerning the ~~inlet pressure and~~ H₂O dependences of the CRDS flow and the spatial inhomogeneity of the pressure field inside the cavity

~~A choked flow is a flow through a critical orifice in which the following condition holds for the inlet to outlet pressure ratio (Van den Bosch & Duijm, 2005):~~

$$\frac{p_i}{p_o} \geq \left(\frac{\gamma+1}{2}\right)^{\gamma/(\gamma-1)} \quad (A1),$$

~~where p_i is the inlet pressure, p_o is the outlet pressure, and γ is the ratio of specific heats (c_p/c_v) for the considered gas. For dry air, γ is equal to 1.4 and the right hand side of Eq. (A1) is equal to 1.893. In a choked flow, the speed is supersonic just downstream the orifice and the flow rate does not depend on the downstream quantities (because “information” cannot propagate faster than sound). Since the minimal recommended inlet pressure for the CRDS G2401 is 0.4 bar and the cavity pressure is 0.167 bar (140 Torr), the flow in the inlet critical orifice is choked. This is the reason by which the flow through the CRDS cavity depends only on upstream quantities (mainly the inlet pressure, as indicated in Sect 3.1), except for Flight-ready models, which have the critical orifice at the outlet of the CRDS cavity, and therefore, the inlet pressure for the orifice is the cavity pressure, which is kept constant.~~

- 30 The theoretical equation relating the standard volumetric flow (F) with the inlet quantities for a choked flow is presented and discussed in Sect. 2.4. ~~is (Van den Bosch & Duijm, 2005):~~

$$F = C_d \cdot A \cdot p_i \cdot \frac{T_s}{p_s} \cdot \left[\frac{\gamma R}{T_i} \cdot \left(\frac{2}{\gamma+1} \right)^{(\gamma+1)/(\gamma-1)} \right]^{1/2} \quad (A2),$$

where T_s and p_s are the standard temperature (273.15 K) and pressure (1.01325 bar) respectively, T_i is the inlet temperature, R is the gas constant, C_d is the discharge coefficient (dimensionless) and A is the hole cross sectional area. Equation (A2) shows that the standard volumetric flow is proportional to the inlet pressure and inversely proportional to the square root of

5 the inlet (absolute) temperature. However, additionally to the dependences on pressure and temperature, there is also a small dependence on the water vapour mole fraction through the ratio of specific heats and the gas constant, which depend slightly on the H2O mole fraction as follows:

$$\frac{1}{R} = \frac{1-r}{R_d} + \frac{r}{R_{H2O}} \quad (A13),$$

where r is the H2O mole fraction in mol/mol, R_d is the gas constant for dry air, and R_{H2O} is the gas constant for H2O;

$$10 \quad \gamma = \frac{1.4+0.4r}{1+0.4r} \quad (A24).$$

In order to estimate the relative impact of water vapour changes on the standard volumetric flow, we need to know approximately the values of C_d and A . To this end, we use this approximate fact obtained from Table 3: when p_i is 0.700 hPa-bar, F is 150 scc/min, and obtain using Eq. (A2) that the product of C_d and A is equal to 1.955e-8 m². Figure A1 shows F and its derivative (with respect to r) as functions of r , for $p_i = 0.700$ hPa-bar and $T_i = 293$ K, showing that the relative

15 impact of r on F is small and the derivative is quite constant for the considered r range (0.00-0.05).

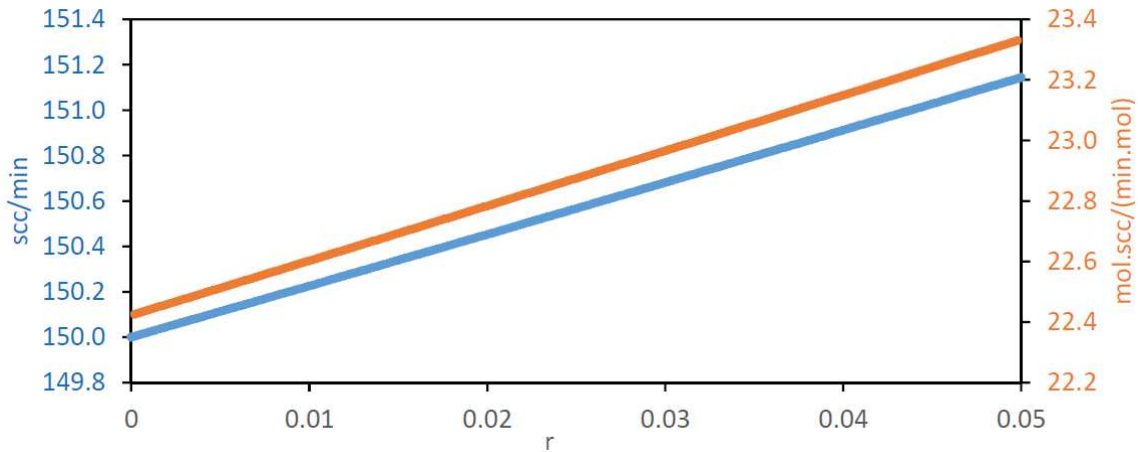

Figure A1: Standard volumetric flow (F) on the left Y-axis and its derivative with respect to r (H2O mole fraction in mol/mol) on the right Y-axis, for $p_i = 0.700$ hPa-bar and $T_i = 293$ K.

20 When there is a stationary air flow through an instrument, the pressure field changes spatially mainly due to two reasons (Bernoulli equation): 1) longitudinal decrease of the pressure due to viscosity, and 2) changes in the cross-section along the pipe, which require flow acceleration (provided by a longitudinal pressure gradient) when the cross-section decreases and flow deceleration when the cross-section increases (e.g., Venturi effect). The structure of the optical cavity of the CRDS

G2401 is shown in Fig. 1 of Crosson (2008). The plane defined by the three mirrors inside the cavity is horizontal (parallel to the surface of the Earth when the instrument is set on its feet on a bench). The inlet and outlet cavity ports are on the top of the cavity. The pressure sensor is on a third port located on the top of the cavity, at the approximate centre (Rella, private communication). Applying considerations of fluid dynamics, we infer the following facts. First, along the sense of flow inside the cavity, there needs to be a very small decrease in pressure in order to be able to balance the resistance to flow due to viscosity, and that decrease will be larger as the mass flow rate is increased. Since the pressure sensor is located in the middle of the cavity, the mean pressure will be monitored. A parcel of fluid flowing along the cavity will expand very slightly (due to the decrease in pressure that the Lagrangian parcel “feels”), and therefore, the temperature will tend to slightly decrease adiabatically in all the points of the volume whereas the heat to compensate it comes from the surface of the cavity. That is, necessarily there needs to be also a small inhomogeneity in the temperature field inside the cavity, and this inhomogeneity depends on the flow rate. The hypothetical net effect on the measurements is difficult to assess a priori without performing a gas dynamics numerical simulation. Second, when a fluid parcel leaves the inlet pipe and enters into the cavity, it feels a large change in the cross-section of the solid material that contains the flow. Therefore, there needs to be a portion of cavity near the inlet with ~~pressure~~ increasing in the flow sense to decrease and accommodate the velocity of the fluid. That is, in the cavity near the inlet, there is a pressure smaller than in the rest of the cavity. Moreover, the opposite process happens in the cavity near the outlet: the fluid needs to be accelerated, and therefore, there needs to be a portion of cavity near the outlet with ~~pressure~~ decreasing in the flow sense. That is, in the cavity near the outlet, there is a smaller pressure than in the rest of the cavity, as happens near the inlet, and this decrease is larger when the mass flow rate is increased. If any portion of those two regions is crossed by the laser path, the perturbation this produces in the measurements agrees in sign with Eq. (31). Therefore, this might be the explanation of the empirically observed effect described in Sect. 3.1.

All the effects pointed out in this ~~appendix section, which~~ are new in the GHG measurement literature according to the knowledge of the authors, ~~might modify the conclusions of Reum et al. (2017).~~

25 **Appendix B. Some additional novelties in the Izaña GHG instrumentation since GGMT-2015**

As mentioned in the talk the main author of the present paper gave at GGMT-2017, we have introduced the following improvements in the dedicated inlet lines of the IZO GHG measurement systems: 1) backpressure regulators for the vents located downstream the pumps, and rotameters for those vents; 2) needle valves in low flow vents installed downstream the cryotrap; 3) glass flask cryotrap with Ultra-Torr connections; and 4) hermetic plugs for unused ports of the rotary Valco valves.

We have prepared two CO₂ laboratory standards of 418.7 ppm for the Izaña NDIRs Li7000 and Li6252 (using two cylinders that have proved to be very stable in previous uses as CO₂ working standards), and calibrated them against our CRDS WMO laboratory standards using the G2401 CRDS.

5 We have reprocessed the Izaña time series of CH₄ and CO in the scales X2004A and X2014A, respectively, taking into account also the drift of the five WMO laboratory standards used in the Izaña RGA-3.

Author contribution. A.J. Gomez-Pelaez designed the measurement system, measurement scheme, and response functions, made the CRDS acceptance tests, configured the CRDS, determined the relationships between flow rate, OV and CRDS inlet pressure, as well as its impact in the CRDS measurements, performed the H₂O droplet tests, ~~wrote~~made the numerical Fortran
10 ~~90~~ codes, analysed the data, made the study of Appendix A, wrote the manuscript and made the plots. R. Ramos installed the measurement system, helped in the routine operation of the system, ~~and~~revised the manuscript, and performed the additional inlet pressure sensitivity tests carried out in 2018. E. Cuevas was the PI of the financed R+D infrastructure project by which the CRDS equipment could be purchased and installed at IZO, and revised in detail the manuscript. V. Gomez-Trueba performed the routine calibrations, and helped performing the additional inlet pressure sensitivity tests carried out in 2018. E.
15 Reyes provided support configuring the CRDS computer, prepared the external media necessary to perform daily copies of the acquired data, and revised the manuscript.

Competing interests. The authors declare that they have no conflict of interest.

20 **Acknowledgements.** The acquisition of the instrument was largely financed by European ERDF funds through the Spanish R+D infrastructure project AEDM15-BE-3319 of the Spanish “Ministerio de Economía, Industria y Competitividad”. This study was developed within the Global Atmospheric Watch (GAW) Programme at the Izaña Atmospheric Research Centre, financed by AEMET. We thank Chris Rella (Picarro, Inc., USA), Christoph Zellweger (EMPA, Switzerland), and Olivier Laurent (ICOS ATC/ LSCE, France) for providing information of great interest about the Picarro G2401 CRDS, and to the
25 Izaña observatory staff. We acknowledge the constructive comments of the anonymous referees.

References

Chen, H., Winderlich, J., Gerbig, C., Hofer, A., Rella, C. W., Crosson, E. R., Van Pelt, A. D., Steinbach, J., Kolle, O., Beck, V., Daube, B. C., Gottlieb, E. W., Chow, V. Y., Santoni, G. W., and Wofsy, S. C.: High-accuracy continuous airborne measurements of greenhouse gases (CO₂ and CH₄) using the cavity ringdown spectroscopy (CRDS) technique, Atmos.
30 Meas. Tech., 3, 375–386, doi:10.5194/amt-3-375-2010, 2010.

- Chen, H., Karion, A., Rella, C. W., Winderlich, J., Gerbig, C., Filges, A., Newberger, T., Sweeney, C., and Tans, P. P.: Accurate measurements of carbon monoxide in humid air using the cavity ring-down spectroscopy (CRDS) technique, *Atmos. Meas. Tech.*, 6, 1031-1040, <https://doi.org/10.5194/amt-6-1031-2013>, 2013.
- Chevallier, F., Ciais, P., Conway, T. J., Aalto, T., Anderson, B. E., Bousquet, P., Brunke, E. G., Ciattaglia, L., Esaki, Y., Frohlich, M., Gomez, A., Gomez-Pelaez, A. J., Haszpra, L., Krummel, P. B., Langenfelds, R. L., Leuenberger, M., Machida, T., Maignan, F., Matsueda, H., Morgui, J. A., Mukai, H., Nakazawa, T., Peylin, P., Ramonet, M., Rivier, L., Sawa, Y., Schmidt, M., Steele, L. P., Vay, S. A., Vermeulen, A. T., Wofsy, S., and Worthy, D.: CO₂ surface fluxes at grid point scale estimated from a global 21 year reanalysis of atmospheric measurements, *J. Geophys. Res.*, 115, D21307, doi: 10.1029/2010JD013887, 2010.
- Crosson, E. R.: A cavity ring-down analyzer for measuring atmospheric levels of methane, carbon dioxide, and water vapor, *Appl. Phys. B-Lasers O.*, 92, 403-408, 2008.
- Cuevas, E., González, Y., Rodríguez, S., Guerra, J. C., Gómez-Peláez, A. J., Alonso-Pérez, S., Bustos, J., and Milford, C.: Assessment of atmospheric processes driving ozone variations in the subtropical North Atlantic free troposphere, *Atmos. Chem. Phys.*, 13, 1973-1998, doi:10.5194/acp-13-1973-2013, 2013.
- Cuevas, E., Milford, C., Bustos, J. J., del Campo-Hernández, R., García, O. E., García, R. D., Gómez-Peláez, A. J., Ramos, R., Redondas, A., Reyes, E., Rodríguez, S., Romero-Campos, P. M., Schneider, M., Belmonte, J., Gil-Ojeda, M., Almansa, F., Alonso-Pérez, S., Barreto, A., González-Morales, Y., Guirado-Fuentes, C., López-Solano, C., Afonso, S., Bayo, C., Berjón, A., Bethencourt, J., Camino, C., Carreño, V., Castro, N. J., Cruz, A. M., Damas, M., De Ory-Ajamil, F., García, M. I., Fernández-de Mesa, C. M., González, Y., Hernández, C., Hernández, Y., Hernández, M. A., Hernández-Cruz, B., Jover, M., Kühl, S. O., López-Fernández, R., López-Solano, J., Peris, A., Rodríguez-Franco, J. J., Sálamo, C., Sepúlveda, E. and Sierra, M.: Izaña Atmospheric Research Center Activity Report 2012-2014. (Eds. Cuevas, E., Milford, C. and Tarasova, O.), State Meteorological Agency (AEMET), Madrid, Spain and World Meteorological Organization, Geneva, Switzerland, NIPO: 281-15-004-2, WMO/GAW Report No. 219, 2015.
- EMPA: System and Performance Audit of Surface Ozone, Methane, Carbon Dioxide, Nitrous Oxide, and Carbon Monoxide at the Global GAW Station Izaña, September 2013, WCC-Empa Report 13/2, 62 pp, https://www.wmo.int/pages/prog/arep/gaw/documents/IZO_2013.pdf, 2013.
- Gomez-Pelaez, A.J., Ramos, R.: "Improvements in the Carbon Dioxide and Methane Continuous Measurement Programs at Izaña Global GAW Station (Spain) during 2007-2009", in GAW report (No. 194) of the "15th WMO/IAEA Meeting of Experts on Carbon Dioxide, Other Greenhouse Gases, and Related Tracer Measurement Techniques (Jena, Germany; September 7-10, 2009)", edited by Willi A. Brand, World Meteorological Organization (TD No. 1553), Geneva, 133-138, 2011.
- Gomez-Pelaez, A.J., Ramos, R., Gomez-Trueba, V., Campo-Hernandez, R., Dlugokencky, E., Conway, T.: "New improvements in the Izaña (Tenerife, Spain) global GAW station in-situ greenhouse gases measurement program" in GAW report (No. 206) of the "16th WMO/IAEA Meeting on Carbon Dioxide, Other Greenhouse Gases, and Related Measurement

- Techniques (GGMT-2011) (Wellington, New Zealand, 25-28 October 2011)", edited by Gordon Brailsford, World Meteorological Organization, Geneva, 76-81, 2012.
- Gomez-Pelaez, A. J., Ramos, R., Gomez-Trueba, V., Novelli, P. C., and Campo-Hernandez, R.: A statistical approach to quantify uncertainty in carbon monoxide measurements at the Izaña global GAW station: 2008–2011, *Atmos. Meas. Tech.*, 6, 787-799, <https://doi.org/10.5194/amt-6-787-2013>, 2013.
- Gomez-Pelaez, A.J., Ramos, R., Gomez-Trueba, V., Campo-Hernandez, R., Reyes-Sanchez, E.: "Izaña Global GAW station greenhouse-gas measurement programme. Novelties and developments during October 2011-May 2013" in GAW report (No. 213) of the "17th WMO/IAEA Meeting on Carbon Dioxide, Other Greenhouse Gases, and Related Measurement Techniques (Beijing, China, June 10-14, 2013)", edited by P. Tans and C. Zellweger, World Meteorological Organization, Geneva, 77-82, 2014.
- Gomez-Pelaez, A. J., Ramos, R., Gomez-Trueba, V., Campo-Hernandez, R., Reyes-Sanchez, E.: "GGMT-2015 Izaña station update: instrumental and processing software developments, scale updates, aircraft campaign, and plumbing design for CRDS" in GAW report (No. 229) of the "18th WMO/IAEA Meeting on Carbon Dioxide, Other Greenhouse Gases, and Related Measurement Techniques (GGMT) (La Jolla, CA, USA, 13-17 September, 2015)", edited by P. Tans and C. Zellweger, World Meteorological Organization, Geneva, 125-131, 2016.
- Hazan, L., Tarniewicz, J., Ramonet, M., Laurent, O., and Abbaris, A.: Automatic processing of atmospheric CO₂ and CH₄ mole fractions at the ICOS Atmosphere Thematic Centre, *Atmos. Meas. Tech.*, 9, 4719-4736, <https://doi.org/10.5194/amt-9-4719-2016>, 2016.
- ICOS-ATC (Integrated Carbon Observation System, Atmospheric Thematic Center), "ICOS Atmospheric Station Specifications", edited by O. Laurent, version 1.2, 2016. <https://icos-atc.lsce.ipsl.fr/filebrowser/download/27251>
- Karion, A., Sweeney, C., Wolter, S., Newberger, T., Chen, H., Andrews, A., Kofler, J., Neff, D., and Tans, P.: Long-term greenhouse gas measurements from aircraft, *Atmos. Meas. Tech.*, 6, 511–526, doi:10.5194/amt-6-511-2013, 2013.
- Patra, P. K., Krol, M. C., Montzka, S. A., Arnold, T., Atlas, E. L., Lintner, B. R., Stephens, B. B., Xiang, B., Elkins, J. W., Fraser, P. J., Ghosh, A., Hints, E. J., Hurst, D. F., Ishijima, K., Krümmel, P. B., Miller, B. R., Miyazaki, K., Moore, F. L., Muhle, J., O'Doherty, S., Prinn, R. G., Steele, L. P., Takigawa, M., Wang, H. J., Weiss, R. F., Wofsy, S. C., Young, D.: Observational evidence for interhemispheric hydroxyl-radical parity, *Nature*, 513, 7517, 219-223, <http://dx.doi.org/10.1038/nature13721>, 2014.
- Rella, C. W.: Accurate and stable carbon monoxide measurements with the Picarro G2302, Picarro Report, 2010.
- Rella, C. W., Chen, H., Andrews, A. E., Filges, A., Gerbig, C., Hatakka, J., Karion, A., Miles, N. L., Richardson, S. J., Steinbacher, M., Sweeney, C., Wastine, B., and Zellweger, C.: High accuracy measurements of dry mole fractions of carbon dioxide and methane in humid air, *Atmos. Meas. Tech.*, 6, 837–860, doi:10.5194/amt-6-837-2013, 2013.
- ~~Reum, F., Gerbig, C., Lavric, J. V., Rella, C. W., and Göckede, M.: An improved water correction function for Picarro greenhouse gas analyzers, *Atmos. Meas. Tech. Discuss.*, <https://doi.org/10.5194/amt-2017-174>, in review, 2017.~~

~~Van den Bosch, C.J.H., Duijm, N.J.: “Outflow and spray release”, in “Methods for the calculation of physical effects due to releases of hazardous substances (liquids and gases)”, chapter 2, Third edition Second revised print, edited by C.J.H Van den Bosch and R.A.P.M. Weterings, The Netherlands Organization of Applied Scientific Research, The Hague, 2.1-2.179, 2005.~~

Rodríguez, S., González, Y., Cuevas, E., Ramos, R., Romero, P. M., Abreu-Afonso, J., and Redondas, A.: Atmospheric nanoparticle observations in the low free troposphere during upward orographic flows at Izaña Mountain Observatory, Atmos. Chem. Phys., 9, 6319-6335, <https://doi.org/10.5194/acp-9-6319-2009>, 2009.

Van den Bosch, C.J.H., Duijm, N.J.: “Outflow and spray release”, in “Methods for the calculation of physical effects due to releases of hazardous substances (liquids and gases)”, chapter 2, Third edition Second revised print, edited by C.J.H Van den Bosch and R.A.P.M. Weterings, The Netherlands Organization of Applied Scientific Research, The Hague, 2.1-2.179, 2005.

10

WMO: 18th WMO/IAEA Meeting on Carbon Dioxide, Other Greenhouse Gases and Related Tracers Measurement Techniques (GGMT-2015), La Jolla, CA, USA, 13–17 September 2015, GAW Report No. 229, chap. Expert group recommendations, World Meteorological Organization, Geneva, Switzerland, 1–51, 2016.

Yver Kwok, C., Laurent, O., Guemri, A., Philippon, C., Wastine, B., Rella, C.W., Vuillemin, C., Truong, F., Delmotte, M., Kazan, V., Darding, M., Lebègue, B., Kaiser, C., Xueref-Rémy, I., and Ramonet, M.: Comprehensive laboratory and field testing of cavity ring-down spectroscopy analyzers measuring H₂O, CO₂, CH₄ and CO, Atmos. Meas. Tech., 8, 3867–3892, doi:10.5194/amt-8-3867-2015, 2015.

Zellweger, C., Steinbacher, M., and Buchmann, B.: Evaluation of new laser spectrometer techniques for in-situ carbon monoxide measurements, Atmos. Meas. Tech., 5, 2555–2567, doi:10.5194/amt-5-2555-2012, 2012.

20

Zellweger, C., Emmenegger, L., Firdaus, M., Hatakka, J., Heimann, M., Kozlova, E., Spain, T. G., Steinbacher, M., van der Schoot, M. V., and Buchmann, B.: Assessment of recent advances in measurement techniques for atmospheric carbon dioxide and methane observations, Atmos. Meas. Tech., 9, 4737-4757, <https://doi.org/10.5194/amt-9-4737-2016>, 2016.