

Method to measure the size-resolved real part of aerosol refractive index using differential mobility analyzer in tandem with single particle soot photometer

Gang Zhao¹, Weilun Zhao¹, Chunsheng Zhao^{1*}

¹ Department of Atmospheric and Oceanic Sciences, School of Physics, Peking University, Beijing, China

*Correspondence to: Chunsheng Zhao (zcs@pku.edu.cn)

Abstract

Knowledge on the refractive index of ambient aerosol can help reduce the uncertainties in estimating aerosol radiative forcing. A new method is proposed to retrieve the size-resolved real part of refractive index (RRI). Main principle of deriving the RRI is measuring the scattering intensity by single particle soot photometer of size-selected aerosol. This method is validated by a series of calibration experiments using the components of known RRI. The retrieved size-resolved RRI cover a wide range from 200 nm to 450 nm with uncertainty less than 0.02. Measurements of the size resolved RRI can improve the understanding of the aerosol radiative effects.

1 Introduction

Aerosols exert significant influence on the earth energy budget by scattering and absorbing radiation (Ramanathan and Carmichael, 2008). There still remain great uncertainties when estimating the aerosol effective radiative forcing (RF) (Ghan and Schwartz, 2007) and an accurate estimation of the aerosol optical properties can help reduce the RF variations. The optical properties of the ambient aerosol particles are determined by their particle size and complex refractive index (RI, $m=n+ki$) (Bohren and Huffman, 2007; Levoni et al., 1997). Despite that the ambient aerosol particle size distribution can be measured with high accuracy (Wiedensohler et al., 2012), an accurate measurement of the ambient aerosol RI remains challenging. The RI is also widely used in remote sensing (Redemann et al., 2000; Dubovik, 2002; Zhao et al., 2017) and atmospheric modelling (Ghan and Schwartz, 2007; Kuang et al., 2015) because the aerosol single scattering albedo (SSA) and aerosol scattering phase function are highly related with the RI. At the same time, a small uncertainty in the real part of the RI (RRI) can lead to great uncertainties when estimating the aerosol RF. Zarzana et al. (2014) found that a variation of 0.003 in RRI can lead to uncertainties of 1% in RF for non-absorbing ammonium sulfate particles. Moise et al. (2015) estimated that the RF would increase 12% when the

30 RRI varied from 1.4 to 1.5. Valenzuela et al. (2018) reported that the uncertainties in RF is estimated
31 to be 7% when the aerosol RRI varied by 0.1. Therefore, it is pressing that the uncertainties of the RI
32 be reduced when estimating the RF.

33 Many methods were proposed to derive the RRI. The RRI can be estimated by linear volume
34 average of the known aerosol chemical components by

$$35 \quad n = \sum_i f_i n_i \quad (1)$$

36 where f_i and n_i is the volume fraction and known partial refractive index of i th component (Wex et
37 al., 2002;Hand and Kreidenweis, 2002;Hänel, 1968;Liu and Daum, 2008). The aerosol RRI can also
38 be calculated by partial molar refraction approach (Stelson, 1990;Hu et al., 2012) which is essentially
39 consistent with the linear volume method (Liu and Daum, 2008). The ambient aerosol RRI can be
40 derived by synthetically using the radiative transfer calculations and the ground-based solar extinction
41 and scattering measurements (Wendisch and Hoyningen-Huene, 1994, 1992). Sorooshian et al. (2008)
42 developed a method to measure the aerosol RRI based on the differential mobility analyzer (DMA)
43 and an optical particle counters. The RRI could be retrieved from the known particle size from the
44 DMA and the aerosol scattering intensity from the Optical Particle Counter (OPC) for aerosol particles
45 larger than 500 nm. The Scanning Mobility Particle Sizer (SMPS) and OPC was used in combination
46 to derive the RRI by aligning the particle size distributions in the instrument overlap regions (Hand
47 and Kreidenweis, 2002;Vratolis et al., 2018). The aerosol effective RRI was also retrieved by applying
48 Mie scattering theory to the aerosol particle number size distribution, aerosol bulk scattering
49 coefficient and aerosol absorbing coefficient data (Cai et al., 2011;Liu and Daum, 2000). Spindler et
50 al. (2007) retrieved the aerosol RRI value by using the cavity ring-down spectroscopy to measuring
51 the scattering and absorbing properties of bulk aerosols. Eidhammer et al. (2008)) measured the light
52 scattering at different angles and retrieved the RRI. Similarly, the aerosol RRI was retrieved by
53 measuring the aerosol phase function (Barkey et al., 2007). Recently, a method by using the single
54 particle mass spectrometry was proposed to measure the aerosol RRI (Zhang et al., 2015). At the same
55 time, aerosol time-of-flight mass spectrometer was proved to be capable of measuring the aerosol RRI
56 (Moffet et al., 2008). The aerosol RRI can also be retrieved from the Mie spectroscopy by using the
57 optical tweezers in the laboratory (Shepherd et al., 2018).

58 Many studies show that aerosol of different diameters share different properties such as shape
59 (Zhang et al., 2016;Peng et al., 2016), density (Qiao et al., 2018), aerosol hygroscopicity (Wang et al.,

60 2017) and most importantly, the chemical components (Liu et al., 2014;Hu et al., 2012). Thus, there
61 might be significant variations in the aerosol RRI for aerosols of different diameters because the
62 aerosol RRI is highly related to the aerosol density (Liu and Daum, 2008) and chemical components
63 (Stelson, 1990). On the other way round, information of the size-resolved aerosol RRI can help to
64 study the chemical information and the aging process of aerosols among different diameters. Therefore,
65 measurement of the size-resolved aerosol RRI is necessary.

66 Up to now, there are few information in the literature of the size-resolved ambient aerosol RRI
67 (Ebert et al., 2004;Kandler et al., 2007;Ebert et al., 2002). Traditionally, the size-resolved ambient
68 aerosols RRI are estimated by measuring the molar fraction or volume fraction of main aerosol
69 chemical compositions. However, the influence of organic component on the aerosol RRI is ignored.
70 The organic component contributes more than 20% of the total aerosol component in the North China
71 Plain (Hu et al., 2012;Liu et al., 2014). At the same time, RRI of the organic aerosol changes
72 significantly between 1.36 and 1.66 (Moise et al., 2015). Ignoring the organic component may lead to
73 significantly uncertainties when estimating the aerosol RRI. There were no technique, to our
74 knowledge, that directly measures the size-resolved aerosol optical properties and derives the size-
75 resolved aerosol RRI.

76 In this study, a novel method is proposed to measure the size-resolved ambient aerosol RRI by
77 using a DMA in tandem with a single particle soot photometer (SP2). The principle of the system is
78 using the SP2 to measure the scattering properties of size-selected aerosols. Knowing the aerosol
79 diameter and corresponding scattering intensity, the size-resolved aerosol RRI can be retrieved based
80 on the Mie scattering theory. This proposed method can measure the ambient aerosol RRI over a wide
81 size range with high accuracy. The measurement system is employed in a field campaign in the North
82 China Plain and the corresponding results are further discussed.

83 The structure of this manuscript is as follows: section 2 provides the instruments setup and details
84 of the instrument. The method to retrieve the size-resolved aerosol RRI is given in section 3. Section
85 4 shows the discussions about the uncertainties of the proposed method and field measurements results
86 of the size-resolved aerosol RRI. Conclusions come at the last part.

87 **2 Instrument**

88 **2.1 Instrument Setup**

89 The instrument setup is schematically shown in fig. 1(a). Firstly, the dried sample aerosols are
 90 guided to a X-ray soft diffusion charger and then lead to a DMA (Model 3081, TSI, USA). The quasi-
 91 monodisperse aerosols that pass through the DMA at a given diameter are then drawn into a SP2 to
 92 measure the aerosol scattering properties with a flow ratio of 0.12 lpm and a condensation particle
 93 counter (CPC, Model 3776, TSI, USA) to count the aerosol number concentration with a flow ratio of
 94 0.28 lpm respectively. Thus, the sample flow (Q_a) of the DMA is 0.4 lpm. Accordingly, the sheath
 95 flow (Q_{sh}) of the DMA is 4 lpm. The DMA is set to scan the aerosols diameter from 12.3 to 697 nm
 96 over a period of 285s and repeats after a pause of 15 s. The combination of DMA, CPC and SP2 can
 97 provide information of aerosol particle number size distribution (PNSD) and size resolved RRI.

98 On 8th, June, 2018, the measurement system was employed at the filed measurement of
 99 AERONET station of BEIJING_PKU (N39°59', E116°18') to test the reliability of retrieving the
 100 ambient size-resolved RRI. This measurement site locates on the north west of the city of Beijing,
 101 China and is about 1.8 km north of the Zhongguancun, Haidian District, which is one of the busiest
 102 areas in Beijing. It is surrounded by two main streets: Zhongguancun North Street to the west and
 103 Chengfu Road to the south. This site can provide representative information of the urban roadside
 104 aerosols (Zhao et al., 2018).

105 **2.2 DMA**

106 When a voltage (V) is applied to the DMA, only a narrow size range of aerosol particles, with the
 107 same electrical mobility (Z_p) can pass through the DMA (Knutson and Whitby, 1975). The Z_p is
 108 expressed as:

$$109 \quad Z_p = \frac{Q_{sh}}{2\pi VL} \ln\left(\frac{r_1}{r_2}\right) \quad (2)$$

110 where Q_{sh} is the sheath flow rate; L is the length of the DMA; r_1 is the outer radius of annular space
 111 and r_2 is the inner radius of the annular space. The transfer function refers to the probability that a
 112 particle with a certain electrical mobility can pass through the DMA. For a given V , the transfer
 113 function is triangular-shaped, with the peaking value of 100% and a half width (HW) of

$$114 \quad \Delta Z_p = Z_p \frac{Q_a}{Q_{sh}} \quad (3)$$

115 The aerosol Z_p , which is highly related to the aerosols diameter (D_p) and the number of elementary
 116 charges on the particle (n), is defined as:

117
$$Z_p = \frac{neC(D_p)}{3\pi\mu D_p} \quad (4)$$

118 where e is the elementary charge; μ is the gas viscosity coefficient, $C(D_p)$ is the Cunningham slip
119 correction that is defined by:

120
$$C = 1 + \frac{2\tau}{D_p} (1.142 + 0.558e^{-\frac{0.999D_p}{2\tau}}) \quad (5)$$

121 where τ is the gas mean free path.

122 Based on the discussion above, the aerosols that pass through the DMA with the same Z_p , can have
123 different D_p and different elementary charges.

124 **2.3 SP2**

125 The SP2 is a widely used instrument that can measure the optical properties of every single particle.
126 The measurement principle and instrumental setup of the SP2 have been discussed in detail previously
127 (Stephens et al., 2003;Schwarz et al., 2006) and will be briefly described here. When the sample
128 aerosol particles pass through the continuous Nd:YAG laser beam at 1064 nm with the circulating
129 power about 1 mW/cm² in the cavity, eight sensors distributed at four directions are synchronously
130 detecting the emitted or scattered light by using avalanche photo-detector (APD) at different angles
131 (45° and 135°). For each direction, the two APDs sample the same signal with different sensitivities to
132 get a wider measurement range. The low gain channels are less sensitive to the measured signal and
133 can be used to measure the stronger signal of larger particles. In accordance, the high gain channels
134 are more sensitive to the measured signal, and can be used to measure the weaker signal of smaller
135 particles. The optical head of the SP2 is shown schematically in fig. 1(b).

136 In this study, we utilize signals from four channels of the SP2: two of them measure the scattering
137 signals and another two measure the incandescent light between 350 nm and 800 nm. The peak height
138 (H) of the incandescence signals is used to infer whether the sampled aerosol contains the black carbon
139 (BC). If the H of the incandescence signal is larger than 500, the sample aerosol contains the BC and
140 the scattering signals should deviate from the signals of pure scattering aerosol. Those sample aerosols
141 are not considered when dealing with the aerosol scattering signals. This is achieved by just studying
142 the signals when the particle are recognized as pure scattering particle.

143 Despite that some aerosol particles are internally mixed with a small BC core, whose
144 incandescence signal is below the detection threshold of SP2, we will demonstrate that these particles

145 have little influence on the retrieved aerosol RRI. At the same time, there are some weakly absorbing
146 organic components that absorb light intensity in the near infrared range, which were termed as brown
147 carbon (BrC). These BrC components have ignorable influence on the retrieving of aerosol RRI, which
148 will be discussed in detail in section 4.2. Thus, the imaginary part of complex refractive index is set to
149 be zero in the following discussion.

150 **3 Methodology**

151 **3.1 Scattering intensity measured by the SP2**

152 From fig. 1(b), the APDs of the SP2 receive signals that were scattered by the sampled aerosols in
153 a certain small range at 45° and 135°. Thus, the scattering intensity (S) measured by the APD can be
154 expressed as:

$$155 \quad S = C_0 \cdot I_0 \cdot \sigma \cdot (PF_{45^\circ} + PF_{135^\circ}) \quad (6)$$

156 where I_0 is the laser's intensity; σ is the scattering coefficient of the sampled aerosol, PF_{45° and
157 PF_{135° are scattering phase function at 45° and 135° respectively of the sampled aerosols; and C_0 is
158 a constant that is determined by the distance from the aerosol to the APD and the area of the APD. The
159 scattering intensity of the aerosol is recorded as the H of the scattering signals in SP2. The following
160 calibration studies show that the scattering intensity S is highly related the H measured by SP2.
161 Therefore, the SP2 can be used as a powerful tool to measure the scattering signals of the sampled
162 aerosols, thus determining the corresponding scattering intensity.

163 Based on the Mie scattering theory, the scattering coefficient σ can be calculated by integrating
164 the square of scattering intensity function $Q(\theta, x, RRI)$ from 0° to 180°. Angle θ is defined as the
165 angle between the light incident direction and scattering light direction. The size parameter x is defined
166 as $x = \frac{\pi D_p}{\lambda}$, where λ is the light incident wavelength. The scattering phase function can be directly
167 derived from $S(\theta, x, m)$, too. Therefor, the σ , PF_{45° and PF_{135° in equation 6 are determined by
168 the D_p and RRI of the aerosol. The amount of scattering signals from the sample aerosol varies with
169 the aerosol D_p and RRI (Bohren and Huffman, 2007). The scattering intensity at different aerosol
170 diameters and RRI is calculated based on equation 6 and shown in fig. 2. The C_0 is assumed to be 1
171 here. From fig. 2, we can see that the aerosol scattering intensity increases monotonously with the
172 increasing aerosol RRI at a given D_p , which makes it possible to retrieve the aerosol RRI with given
173 D_p and the scattering intensity.

174 Bridging the scattering H values measured by the SP2 scattering channel and the scattering
175 intensity S defined by equation 6 is achieved by calibrating the SP2 with ammonium sulfate. The
176 instrument setup of the calibration procedure is the same as that described in section 2.1. The diameters
177 of the aerosols passing through the DMA are manually changed from 100 to 450 nm with a step of 10
178 nm. For each diameter, the scattering H value and incandescence signal of every particle are analyzed.
179 When calibrating, there is no aerosol whose incandescence signal exceeds 1000 (This value depends
180 on the stability of the instrument and working conditions. It can be different for different instrument),
181 which means that the SP2 works stably and the incandescence signal channel can well distinguish the
182 BC containing aerosols. With the calibration, the relationship between the measured H and
183 theoretically calculated S can be determined.

184 The procedure of retrieving the RRI are summarized as follows: (1) measuring the scattering H
185 values at a given Dp ; (2) transferring the H into to S by the established relationship from calibration;
186 (3) calculating the refractive index with the given Dp and S by using equation 6.

187 **3.2 Multiple Charging**

188 Fig. S1 gives the aerosols scattering H probability distribution under different aerosol diameters.
189 For each diameter, the distributions of the scattering H may have more than one mode for both the high
190 gain and low gain channels. The following discussions would give explanation about the multiple
191 mode distributions of H .

192 For each mode, the number of recorded aerosol particles at a given H is fit by the log-normal
193 distribution function:

$$194 \quad N(H) = \frac{N_0}{\sqrt{2\pi}\log(\sigma_g)} \cdot \exp\left[-\frac{\log(H)-\log(H_0)}{2\log^2(\sigma_g)}\right] \quad (7)$$

195 Where σ_g is the geometric standard deviation; H_0 is the geometric mean value of H and N_0 is the
196 number concentrations for a peak mode. The geometric standard deviation is highly related to the half
197 width of the transfer function (equation 3). The H_0 is further used for discussion in the following part.

198 The H_0 values of corresponding to different elementary charges are labeled with different markers
199 in fig. 3. The σ_g is fitted to be a small range at 1.182 ± 0.02 for different modes and different aerosol
200 diameters. In the following discussion, we conclude that the different H_0 values in fig. 3 represent that
201 the aerosols are charged with different number of elementary charges. Based on the Mie scattering

202 theory (Bohren and Huffman, 2007), the scattering intensity increases with increasing Dp , which imply
203 that the H_0 of the singly charged aerosol should increase with the increment of Dp . Thus, the black
204 square markers in fig. 3 represent the aerosols that are singly charged. At the same time, the
205 relationships between the H_0 and Dp can be interpolated.

206 Other colored markers represent that the aerosols have more than one charge. We calculated the
207 corresponding diameter (\widetilde{Dp}) of the aerosols that share the same Z_p but different charges with those
208 particles that have diameter of Dp with one charge. Then the corresponding \widetilde{H}_0 at \widetilde{Dp} are calculated.
209 Then the relationship between \widetilde{H}_0 and Dp is shown in dashed line in fig. 3(a). From fig. 3(a), the
210 calculated H_0 shows good consistence with the measured H_0 .

211 From the discussion above, we conclude that the SP2 can only detect those ammonium sulfate
212 aerosols with the diameter larger than 160 nm. However, the ambient aerosol RRI is always lower than
213 that of ammonium sulfate (Liu and Daum, 2008), thus the lower detecting limit of the ambient
214 scattering aerosols should be larger than 160 nm. The measured H_0 of the SP2 scattering low gain
215 channel signals are shown in fig. 3(b). From fig. 3(b), the same results can be deduced as those of the
216 high gain channel signals.

217 Fig. 4(a) gives the relationships between the calculated scattering intensity and the SP2 aerosol
218 scattering H_0 at different diameters. When calculating the scattering intensity, the RRI value of
219 ammonium sulfate is set to be 1.521 (Flores et al., 2009), and the C_0 in equation 6 is set to be unity.
220 The aerosol scattering intensity shows good consistence with the peak height ($R^2=0.9992$), which to
221 some extent reflect the high accuracy of our proposed method. When regressing the scattering intensity
222 on the measured peak height, the value 0.36 were obtained for the slope, which means that the
223 scattering intensity can be calculated by multiplying the peak height with a factor of 0.36.

224 3.3 Validation of the calibration

225 Ammonium chloride is used to validate the method of deriving the RRI from SP2. The RRI value
226 of ammonium chloride is 1.642 (Lide, 2006). The scattering H of the ammonium chloride under
227 different diameters are measured and analyzed. Fig. 4(b) shows the comparison between the measured
228 scattering high gain peak heights and the theoretical peak heights at different aerosols diameters.
229 Results show that the measured peak heights and the calculated ones are well correlated with
230 $R^2=0.9994$, which means that the DMA and SP2 can be used to derived the aerosol RRI with high
231 accuracy.

232 Fig. S2 gives the corresponding results of the scattering low gain channel. In fig. S2, the
233 relationship between the aerosol scattering peak height of the low gain channel and the scattering
234 intensity is determined. At the same time, the comparison between the measured peak height and the
235 calculated peak height shows good consistence too.

236 **4.1 Field Measurements**

237 Figure 5 shows the measured average probability distribution of the ambient size-resolved RRI
238 and the measured mean PNSD over two hours during the measurement. From fig. 5, we can see that
239 the derived RRI is 1.46 ± 0.02 and doesn't vary significantly with diameter between 199 nm and 436
240 nm.

241 The measured aerosol PNSD during the measurement has a maximum of 26400 \#/cm^3 at 107 nm.
242 The mass concentration of the BC measured by the SP2 is 6.31 \mu g/m^3 . Based on the measured PNSD
243 and the measured RRI, the size distribution of the scattering coefficient is calculated based on the Mie
244 scattering theory. The results in fig. 5 show that the measured RRI diameter range covers most of the
245 aerosol that contributes a fraction of 0.63 to the aerosol scattering properties withThe integrated
246 scattering coefficient at 385 Mm^{-1} . Thus, the derived size-resolved RRI of this range is representative
247 of the ambient aerosols scattering properties.

248 **4.2 Uncertainty analysis**

249 **4.2.1 Uncertainties from SP2**

250 The factors that influence the accuracy of retrieving RRI include the aerosols scattering H
251 measured by SP2 and the aerosol diameter selected by DMA.

252 The uncertainties of the selected diameter by DMA are well characterized based on equation 2 and
253 3. The uncertainties from the DMA transfer function can be avoided by fitting the scattering H using
254 the log-normal distribution function. However, the uncertainties of the measured H from the SP2
255 remain unknown. The half width ($\Delta Z_p/Z_p$) of the transfer function is 0.1 times the scanning diameter,
256 which means that the geometric standard deviation of the aerosol PNSD selected by the DMA is
257 estimated to be 1.102. At the same time, the measured geometric standard deviation of the measured
258 H mode by SP2 is 1.182. Thus, the additional broadening by the H distribution is 1.073, which implies
259 that the geometric standard deviation of the measured H from the SP2 is estimated to be 1.073, whose
260 corresponding uncertainties is 6.8%.

261 The uncertainties of the retrieved RRI to the variations in the measured H are analyzed. Firstly,
262 we calculated the theoretical scattering intensity that can be measured by the SP2 for a given aerosol
263 diameter and RRI. The scattering intensity are changed by $\pm 6.8\%$ and the corresponding RRI can be
264 derived using the given aerosol diameter and changed scattering intensity. Finally, the derived RRI are
265 compared with the given aerosol RRI. The uncertainties are analyzed for different aerosol diameter
266 and different RRI. The corresponding results are shown in fig. 6. The variations in RRI increase with
267 the increment of RRI but decrease with the increment of the D_p . For most ambient aerosols, the RRI
268 ranges from 1.4 to 1.5 and corresponds to a variation in RRI of 0.015.

269 Table 1 lists the retrieved ammonium chloride RRI under different diameters. The absolute
270 difference between the retrieved RRI and theoretical values is always smaller than 0.02 regardless of
271 the particle diameter, which means that the measured RRI is in line with the theoretical one. Thus, we
272 conclude that the uncertainty of the retrieved RRI is within 0.02 due to the uncertainties of SP2
273 measurement.

274 **4.2.2 Uncertainties due to BC exists**

275 There are some particles with a small soot core and the incandescence signal is below the detection
276 threshold of SP2. The derived aerosol RRI should be influenced by small soot core. Uncertainties
277 might be resulted when deriving the RRI for these BC-contained aerosols. With the calibration of the
278 SP2 with Aquadag soot particles, we concluded that the SP2 can't detect the soot particles lower than
279 80 nm, which is shown in detail in supplementary material in section S3.

280 We derived the aerosol equivalent refractive index when the aerosol have BC cores lower than 80
281 nm with two steps. The scattering strength of the BC-containing aerosols are first calculated based on
282 Mie scattering theory. Then the scattering strength are used to deriving the equivalent refractive index
283 with assuming that the BC-containing aerosols are pure scattering aerosols.

284 Monte Carlo simulations were applied to investigate the influence of the BC core on the retrieved
285 ambient aerosol RRI. Firstly, aerosol with diameter between 200 nm and 500 nm was chosen. Then
286 the core diameter are random determined lower than 80 nm. The core diameters flow the log-normal
287 distribution with the mean core diameter of 120 nm (Raatikainen et al., 2017). When calculating the
288 scattering strength, the complex refractive index of the core $1.8+0.54i$ (Zhao et al., 2018) is used. The
289 complex refractive of the shell adopts the measured mean values ($1.46+0i$) during the field

290 measurements. The scattering strength can be calculated with the above information. With the
291 calculated scattering strength, the equivalent real part of the refractive index (RRI) can be derived with
292 assuming that the aerosols are pure scattering aerosols. If the core diameter is 0, then the derived
293 aerosol equivalent aerosol RRI should be 1.46.

294 For each aerosol diameter, the Monte Carlo simulations were conducted for 10000 times. Fig. 7(a)
295 gives the retrieved aerosol equivalent RRI at different diameters. Results show that the retrieved
296 aerosol equivalent RRI are larger than 1.46 for all of the given aerosol diameters. When the aerosols
297 have BC core, the scattering strength are larger than that of pure scattering aerosols with the same
298 aerosol diameter. The derived mean equivalent RRI tend to be closer to 1.46 when the aerosol diameter
299 are larger, where the BC core contributes less and the influence of the BC core are be smaller. The
300 derived mean aerosol equivalent RRI is 1.47 and 1.462 at 200 nm and 500 nm respectively. At the
301 same time, the uncertainties associated with the equivalent RRI are larger when the aerosol diameter
302 are smaller. We conclude that the uncertainties associated with BC core are smaller than 0.01 when
303 the aerosol diameter are larger than 250 nm. The maximum of the difference of the derived RRI is
304 0.02.

305 4.2.3 Uncertainties from BrC

306 There are some BrCs that absorb the light intensity in the near infrared range. The imaginary part
307 of the refractive index at a given wavelength λ (k_λ) of the BrC can be calculated as:

$$308 \quad k_{\lambda_1} = k_{\lambda_2} \times \left(\frac{\lambda_2}{\lambda_1}\right)^w \quad (8)$$

309 Where w is defined by mass of BC to organic aerosol ratio (R) (Saleh et al., 2015)with:

$$310 \quad w = \frac{0.21}{R+0.07} \quad (9)$$

311 Based on the work of Saleh et al. (2015), the k_{550} can be expressed as:

$$312 \quad k_{550} = 0.016 \times \log_{10}(R) + 0.04 \quad (10)$$

313 The values R ranges between 0.09 and 0.35 for different types of aerosols (Saleh et al., 2015).
314 Based on equation (8), (9) and (10), the k_{1024} ranges between 0.01 and 0.024. The maximum value
315 0.024 is used for further analysis.

316 The uncertainties of the retrieved RRI when ignoring the effect of BrC are analyzed. Firstly, The
317 scattering light intensity at a given diameter with a refractive index of $1.46 + 0.024i$ is calculated using
318 the Mie model. Then the corresponding RRI are retrieved using given diameter and the calculated light

319 intensity with assumption that these are pure scattering aerosols. The retrieved aerosol RRI values for
320 different aerosol diameter are shown in fig. 7(b). For the light absorbing particles, their scattering light
321 intensity is smaller than that of the pure scattering particles with the same diameter and RRI. Therefore,
322 the retrieved aerosol RRI is underestimated for most of the conditions. The differences between the
323 given RRI value (1.46) and retrieved RRI value are lower than 0.006 for all of the diameters as shown
324 in fig. 7(b). The BrC component has little influence on the retrieved aerosol RRI.

325 **4.2.4 Overall of the uncertainties**

326 Monte Carlo simulations were conducted to study the influence of the above three uncertainty
327 sources. Four steps are involved in the Monte Carlo simulations. First, the core diameter of an aerosol
328 particle at a given diameter are randomly given with the core diameter following the log-normal
329 distribution with the mean core diameter of 120 nm (Raatikainen et al., 2017). The refractive index of
330 the core is set to be the same as that in section 4.2.2. The RRI of the shell uses the measured mean
331 value 1.46. The imaginary part of the shell is determined randomly with a mean value of 0.023. Second,
332 the light scattering intensity can be calculated using the Mie model and the information in step one.
333 Then the light scattering intensity was randomly changed with uncertainties of 6.8%. Finally, the
334 changed light scattering intensity are used to derive the aerosol RRI with the given diameter and
335 assumption that the particles are pure scattering particles.

336 The aerosol diameters were changed from 200 nm to 500 nm, and the simulations were conducted
337 for 10000 times for each diameter. The overall uncertainties are shown in fig. 7(c). The uncertainties
338 from SP2 instrument measurement don't lead to bias of the retrieved aerosol RRI. When the aerosol
339 diameter is lower than 300 nm, the influence of the BC core is more important than the influence of
340 BrC. The retrieved RRI tend to be overestimated when the aerosol is lower than 300 nm. When the
341 aerosol diameter is larger than 300 nm, the influence of BrC domains and the retrieved aerosol RRI
342 are underestimated. However, the bias caused by BC and BrC are all the way lower than 0.01. For
343 most of the conditions, the retrieved aerosol RRI are within the range of 1.46 ± 0.02 . Thus, we conclude
344 that the uncertainty of the retrieved RRI is 0.02 with considering all of the factors.

345 **5 Conclusions**

346 Knowledge on the microphysical properties of ambient aerosol is important for better evaluating their
347 radiative forcing. The aerosol RRI is a key factor that determines the aerosol scattering properties. In

348 this study, a new method to measure the ambient aerosol RRI is developed by synthetically using a
349 DMA in tandem with a SP2. This method can continuously measure the size-resolved RRI over a wide
350 range between 198 nm and 426 nm. At the same time, it is free from the influence of the BC containing
351 aerosols.

352 The basic principle of measuring the size-resolved RRI is to select the aerosols at a certain
353 diameter by the DMA and measure the corresponding scattering intensity by the SP2. The relationship
354 between the aerosols scattering intensity and the peak height of the scattering signal channels are
355 determined by calibrating the SP2 using ammonium sulfate (RRI=1.521).

356 The method is validated by measuring the size-resolved RRI of the ammonium chloride with the
357 RRI value of 1.642 as sample aerosol and the corresponding derived value is 1.642 ± 0.02 . There are
358 three factors that influence the accuracy of derived aerosol RRI. The measured scattering intensity by
359 SP2 has an uncertainty of 0.68%, which can lead to the uncertainties of the derived RRI values less
360 than 0.15. There are some particles with a small soot core and the incandescence signal is below the
361 detection threshold of SP2. The light scattering intensity of these particles increases compared with
362 that of the pure scattering particles with the same aerosol diameters. The retrieved aerosol RRI values
363 can be overestimated by up to 0.02. Some BrCs absorb the light intensity in the near infrared range.
364 The corresponding scattering intensity is weaker than that of pure scatter particles for the same
365 diameter and the retrieved aerosol RRI value can be underestimated by up to 0.006. Based on Monte
366 Carlo simulations, the uncertainty of the retrieved RRI is 0.02 with considering all of the factors.

367 This instrument is employed at a field measurement at the AERONET PKU station, the size-
368 resolved RRI of the ambient aerosols is 1.46 and doesn't show significant variation among the diameter.
369 The corresponding aerosol diameter range, which can be detected by SP2 to derive the RRI, covers
370 most of the aerosol scattering. Thus, the derived size-resolved RRI of this range can be used as a good
371 representative of the ambient aerosols scattering properties.

372

373 **Data availability.** The measurement data involved in this study are available upon request to the
374 authors.

375

376 **Author contributions.** Gang Zhao and Chunsheng Zhao designed the experiments; Gang Zhao and
377 Weilun Zhao conducted the measurements; Chunsheng Zhao and Gang Zhao discussed the results and
378 wrote the manuscript.

379

380 **Competing interests.** The authors declare that they have no conflict of interest.

381

382 **Acknowledgments.** This work is supported by the National Key R&D Programa of China
383 (2016YFC020000:Task 5) and the National Natural Science Foundation of China (41590872).

384

385

386 Barkey, B., Paulson, S. E., and Chung, A.: Genetic Algorithm Inversion of Dual Polarization Polar
387 Nephelometer Data to Determine Aerosol Refractive Index, *Aerosol Sci. Technol.*, 41, 751-760,
388 10.1080/02786820701432640, 2007.

389 Bohren, C. F., and Huffman, D. R.: Absorption and Scattering by a Sphere, in: *Absorption and*
390 *Scattering of Light by Small Particles*, Wiley-VCH Verlag GmbH, 82-129, 2007.

391 Cai, Y., Montague, D. C., and Deshler, T.: Comparison of measured and calculated scattering from
392 surface aerosols with an average, a size-dependent, and a time-dependent refractive index, *Journal of*
393 *Geophysical Research*, 116, 10.1029/2010jd014607, 2011.

394 Dick, W. D., Ziemann, P. J., and McMurry, P. H.: Multiangle Light-Scattering Measurements of
395 Refractive Index of Submicron Atmospheric Particles, *Aerosol Sci. Technol.*, 41, 549-569,
396 10.1080/02786820701272012, 2007.

397 Dubovik, O.: Variability of absorption and optical properties of key aerosol types observed in
398 worldwide locations, *J.atmos.sci.*, 59, 590-608, 2002.

399 Ebert, M., Weinbruch, S., Rausch, A., Gorzawski, G., Helas, G., Hoffmann, P., and Wex, H.: Complex
400 refractive index of aerosols during LACE 98#x2010; as derived from the analysis of individual
401 particles, *Journal of Geophysical Research: Atmospheres*, 107, LAC 3-1-LAC 3-15,
402 10.1029/2000jd000195, 2002.

403 Ebert, M., Weinbruch, S., Hoffmann, P., and Ortner, H. M.: The chemical composition and complex
404 refractive index of rural and urban influenced aerosols determined by individual particle analysis,
405 *Atmospheric Environment*, 38, 6531-6545, 10.1016/j.atmosenv.2004.08.048, 2004.

406 Eidhammer, T., Montague, D. C., and Deshler, T.: Determination of index of refraction and size of
407 supermicrometer particles from light scattering measurements at two angles, *Journal of Geophysical*
408 *Research*, 113, 10.1029/2007jd009607, 2008.

409 Flores, J. M., Trainic, M., Borrmann, S., and Rudich, Y.: Effective broadband refractive index retrieval
410 by a white light optical particle counter, *Phys Chem Chem Phys*, 11, 7943-7950, 10.1039/b905292e,
411 2009.

412 Ghan, S. J., and Schwartz, S. E.: Aerosol Properties and Processes: A Path from Field and Laboratory
413 Measurements to Global Climate Models, *Bulletin of the American Meteorological Society*, 88, 1059-
414 1084, 10.1175/bams-88-7-1059, 2007.

415 Hand, J. L., and Kreidenweis, S. M.: A New Method for Retrieving Particle Refractive Index and
416 Effective Density from Aerosol Size Distribution Data, *Aerosol Sci. Technol.*, 36, 1012-1026,
417 10.1080/02786820290092276, 2002.

418 Hänel, G.: REAL PART OF MEAN COMPLEX REFRACTIVE INDEX AND MEAN DENSITY OF
419 SAMPLES OF ATMOSPHERIC AEROSOL PARTICLES, *Tellus*, 20, 371-&, 377,
420 10.3402/tellusa.v20i3.10016, 1968.

421 Hu, M., Peng, J., Sun, K., Yue, D., Guo, S., Wiedensohler, A., and Wu, Z.: Estimation of size-resolved
422 ambient particle density based on the measurement of aerosol number, mass, and chemical size
423 distributions in the winter in Beijing, *Environ Sci Technol*, 46, 9941-9947, 10.1021/es204073t, 2012.

424 Kandler, K., Benker, N., Bundke, U., Cuevas, E., Ebert, M., Knippertz, P., Rodríguez, S., Schütz, L.,
425 and Weinbruch, S.: Chemical composition and complex refractive index of Saharan Mineral Dust at
426 Izaña, Tenerife (Spain) derived by electron microscopy, *Atmospheric Environment*, 41, 8058-8074,
427 10.1016/j.atmosenv.2007.06.047, 2007.

428 Knutson, E. O., and Whitby, K. T.: Aerosol classification by electric mobility: apparatus, theory, and
429 applications, *Journal of Aerosol Science*, 6, 443-451, [https://doi.org/10.1016/0021-8502\(75\)90060-9](https://doi.org/10.1016/0021-8502(75)90060-9),
430 1975.

431 Kuang, Y., Zhao, C. S., Tao, J. C., and Ma, N.: Diurnal variations of aerosol optical properties in the
432 North China Plain and their influences on the estimates of direct aerosol radiative effect, *Atmos. Chem.*
433 *Phys.*, 15, 5761-5772, 10.5194/acp-15-5761-2015, 2015.

434 Levoni, C., Cervino, M., Guzzi, R., and Torricella, F.: Atmospheric aerosol optical properties: a
435 database of radiative characteristics for different components and classes, *Appl Opt*, 36, 8031-8041,

436 1997.

437 Lide, D. R.: Handbook of Chemistry and Physics, 86th Edition Edited(National Institute of Standards
438 and Technology), Journal of the American Chemical Society, 128, 5585-5585, 10.1021/ja059868l,
439 2006.

440 Liu, H. J., Zhao, C. S., Nekat, B., Ma, N., Wiedensohler, A., van Pinxteren, D., Spindler, G., Müller,
441 K., and Herrmann, H.: Aerosol hygroscopicity derived from size-segregated chemical composition and
442 its parameterization in the North China Plain, Atmospheric Chemistry and Physics, 14, 2525-2539,
443 10.5194/acp-14-2525-2014, 2014.

444 Liu, Y., and Daum, P. H.: THE EFFECT OF REFRACTIVE INDEX ON SIZE DISTRIBUTIONS
445 AND LIGHT SCATTERING COEFFICIENTS DERIVED FROM OPTICAL PARTICLE
446 COUNTERS ☆, Journal of Aerosol Science, 31, 945-957, 2000.

447 Liu, Y., and Daum, P. H.: Relationship of refractive index to mass density and self-consistency of
448 mixing rules for multicomponent mixtures like ambient aerosols, Journal of Aerosol Science, 39, 974-
449 986, 10.1016/j.jaerosci.2008.06.006, 2008.

450 Moffet, R. C., Qin, X., Rebotier, T., Furutani, H., and Prather, K. A.: Chemically segregated optical
451 and microphysical properties of ambient aerosols measured in a single-particle mass spectrometer,
452 Journal of Geophysical Research, 113, 10.1029/2007jd009393, 2008.

453 Moise, T., Flores, J. M., and Rudich, Y.: Optical properties of secondary organic aerosols and their
454 changes by chemical processes, Chemical Reviews, 115, 4400-4439, 2015.

455 Peng, J., Hu, M., Guo, S., Du, Z., Zheng, J., Shang, D., Levy Zamora, M., Zeng, L., Shao, M., Wu, Y.-
456 S., Zheng, J., Wang, Y., Glen, C. R., Collins, D. R., Molina, M. J., and Zhang, R.: Markedly enhanced
457 absorption and direct radiative forcing of black carbon under polluted urban environments,
458 Proceedings of the National Academy of Sciences, 113, 4266-4271, 10.1073/pnas.1602310113, 2016.

459 Qiao, K., Wu, Z., Pei, X., Liu, Q., Shang, D., Zheng, J., Du, Z., Zhu, W., Wu, Y., Lou, S., Guo, S.,
460 Chan, C. K., Pathak, R. K., Hallquist, M., and Hu, M.: Size-resolved effective density of submicron
461 particles during summertime in the rural atmosphere of Beijing, China, Journal of Environmental
462 Sciences, 10.1016/j.jes.2018.01.012, 2018.

463 Raatikainen, T., Brus, D., Hooda, R. K., Hyvärinen, A.-P., Asmi, E., Sharma, V. P., Arola, A., and
464 Lihavainen, H.: Size-selected black carbon mass distributions and mixing state in polluted and clean

465 environments of northern India, *Atmospheric Chemistry and Physics*, 17, 371-383, 10.5194/acp-17-
466 371-2017, 2017.

467 Ramanathan, V., and Carmichael, G.: Global and regional climate changes due to black carbon, *Nature*
468 *Geoscience*, 1, 221-227, 10.1038/ngeo156, 2008.

469 Redemann, J., Turco, R. P., Liou, K. N., Russell, P. B., Bergstrom, R. W., Schmid, B., Livingston, J.
470 M., Hobbs, P. V., Hartley, W. S., Ismail, S., Ferrare, R. A., and Browell, E. V.: Retrieving the vertical
471 structure of the effective aerosol complex index of refraction from a combination of aerosol in situ and
472 remote sensing measurements during TARFOX, *Journal of Geophysical Research: Atmospheres*, 105,
473 9949-9970, 10.1029/1999jd901044, 2000.

474 Saleh, R., Marks, M., Heo, J., Adams, P. J., Donahue, N. M., and Robinson, A. L.: Contribution of
475 brown carbon and lensing to the direct radiative effect of carbonaceous aerosols from biomass and
476 biofuel burning emissions, *Journal of Geophysical Research: Atmospheres*, 120, 2085-210,296,
477 doi:10.1002/2015JD023697, 2015.

478 Schwarz, J. P., Gao, R. S., Fahey, D. W., Thomson, D. S., Watts, L. A., Wilson, J. C., Reeves, J. M.,
479 Darbeheshti, M., Baumgardner, D. G., Kok, G. L., Chung, S. H., Schulz, M., Hendricks, J., Lauer, A.,
480 Kärcher, B., Slowik, J. G., Rosenlof, K. H., Thompson, T. L., Langford, A. O., Loewenstein, M., and
481 Aikin, K. C.: Single-particle measurements of midlatitude black carbon and light-scattering aerosols
482 from the boundary layer to the lower stratosphere, *Journal of Geophysical Research*, 111,
483 10.1029/2006jd007076, 2006.

484 Shepherd, R. H., King, M. D., Marks, A. A., Brough, N., and Ward, A. D.: Determination of the
485 refractive index of insoluble organic extracts from atmospheric aerosol over the visible
486 wavelength range using optical tweezers, *Atmospheric Chemistry and Physics*, 18, 5235-5252,
487 10.5194/acp-18-5235-2018, 2018.

488 Sorooshian, A., Hersey, S., Brechtel, F. J., Corless, A., Flagan, R. C., and Seinfeld, J. H.: Rapid, Size-
489 Resolved Aerosol Hygroscopic Growth Measurements: Differential Aerosol Sizing and
490 Hygroscopicity Spectrometer Probe (DASH-SP), *Aerosol Sci. Technol.*, 42, 445-464,
491 10.1080/02786820802178506, 2008.

492 Spindler, C., Riziq, A. A., and Rudich, Y.: Retrieval of Aerosol Complex Refractive Index by
493 Combining Cavity Ring Down Aerosol Spectrometer Measurements with Full Size Distribution
494 Information, *Aerosol Sci. Technol.*, 41, 1011-1017, 10.1080/02786820701682087, 2007.

495 Stelson, A. W.: Urban aerosol refractive index prediction by partial molar refraction approach,
496 *Environ.sci.technol*, 24:11, 1676-1679, 1990.

497 Stephens, M., Turner, N., and Sandberg, J.: Particle identification by laser-induced incandescence in a
498 solid-state laser cavity, *Appl Opt*, 42, 3726-3736, 2003.

499 Valenzuela, A., Reid, J. P., Bzdek, B. R., and Orr-Ewing, A. J.: Accuracy required in measurements of
500 refractive index and hygroscopic response to reduce uncertainties in estimates of aerosol radiative
501 forcing efficiency, *Journal of Geophysical Research: Atmospheres*, 10.1029/2018jd028365, 2018.

502 Vratolis, S., Fetfatzis, P., Argyrouli, A., Papayannis, A., Müller, D., Veselovskii, I., Bougiatioti, A.,
503 Nenes, A., Remoundaki, E., Diapouli, E., Manousakas, M., Mylonaki, M., and Eleftheriadis, K.: A
504 new method to retrieve the real part of the equivalent refractive index of atmospheric aerosols, *Journal*
505 *of Aerosol Science*, 117, 54-62, 10.1016/j.jaerosci.2017.12.013, 2018.

506 Wang, Y., Wu, Z., Ma, N., Wu, Y., Zeng, L., Zhao, C., and Wiedensohler, A.: Statistical analysis and
507 parameterization of the hygroscopic growth of the sub-micrometer urban background aerosol in
508 Beijing, *Atmospheric Environment*, 10.1016/j.atmosenv.2017.12.003, 2017.

509 Wendisch, M., and Hoyningen-Huene, W. V.: Optically equivalent refractive index of atmospheric
510 aerosol particles, *Huene*, 65, 1992.

511 Wendisch, M., and Hoyningen-Huene, W. V.: Possibility of refractive index determination of
512 atmospheric aerosol particles by ground-based solar extinction and scattering measurements,
513 *Atmospheric Environment*, 28, 785-792, 1994.

514 Wex, H., Neusüß, C., Wendisch, M., Stratmann, F., Koziar, C., Keil, A., Wiedensohler, A., and Ebert,
515 M.: Particle scattering, backscattering, and absorption coefficients: An in situ closure and sensitivity
516 study, *Journal of Geophysical Research: Atmospheres*, 107, LAC 4-1-LAC 4-18,
517 10.1029/2000jd000234, 2002.

518 Wiedensohler, A., Birmili, W., Nowak, A., Sonntag, A., Weinhold, K., Merkel, M., Wehner, B., Tuch,
519 T., Pfeifer, S., Fiebig, M., Fjåraa, A. M., Asmi, E., Sellegri, K., Depuy, R., Venzac, H., Villani, P., Laj,
520 P., Aalto, P., Ogren, J. A., Swietlicki, E., Williams, P., Roldin, P., Quincey, P., Hüglin, C., Fierz-
521 Schmidhauser, R., Gysel, M., Weingartner, E., Riccobono, F., Santos, S., Gruning, C., Faloon, K.,
522 Beddows, D., Harrison, R., Monahan, C., Jennings, S. G., O'Dowd, C. D., Marinoni, A., Horn, H. G.,
523 Keck, L., Jiang, J., Scheckman, J., McMurry, P. H., Deng, Z., Zhao, C. S., Moerman, M., Henzing, B.,
524 de Leeuw, G., Löschau, G., and Bastian, S.: Mobility particle size spectrometers: harmonization of

525 technical standards and data structure to facilitate high quality long-term observations of atmospheric
526 particle number size distributions, *Atmospheric Measurement Techniques*, 5, 657-685, 10.5194/amt-
527 5-657-2012, 2012.

528 Zarzana, K. J., Cappa, C. D., and Tolbert, M. A.: Sensitivity of Aerosol Refractive Index Retrievals
529 Using Optical Spectroscopy, *Aerosol Sci. Technol.*, 48, 1133-1144, 10.1080/02786826.2014.963498,
530 2014.

531 Zhang, G., Bi, X., Han, B., Qiu, N., Dai, S., Wang, X., Sheng, G., and Fu, J.: Measurement of aerosol
532 effective density by single particle mass spectrometry, *Science China Earth Sciences*, 59, 320-327,
533 10.1007/s11430-015-5146-y, 2015.

534 Zhang, Y., Zhang, Q., Cheng, Y., Su, H., Kecorius, S., Wang, Z., Wu, Z., Hu, M., Zhu, T., Wiedensohler,
535 A., and He, K.: Measuring the morphology and density of internally mixed black carbon with SP2 and
536 VTDMA: new insight into the absorption enhancement of black carbon in the atmosphere,
537 *Atmospheric Measurement Techniques*, 9, 1833-1843, 10.5194/amt-9-1833-2016, 2016.

538 Zhao, G., Zhao, C., Kuang, Y., Tao, J., Tan, W., Bian, Y., Li, J., and Li, C.: Impact of aerosol
539 hygroscopic growth on retrieving aerosol extinction coefficient profiles from elastic-backscatter lidar
540 signals, *Atmospheric Chemistry and Physics*, 17, 12133-12143, 10.5194/acp-17-12133-2017, 2017.

541 Zhao, G., Zhao, C., Kuang, Y., Bian, Y., Tao, J., Shen, C., and Yu, Y.: Calculating the aerosol
542 asymmetry factor based on measurements from the humidified nephelometer system, *Atmospheric
543 Chemistry and Physics*, 18, 9049-9060, 10.5194/acp-18-9049-2018, 2018.

544

545

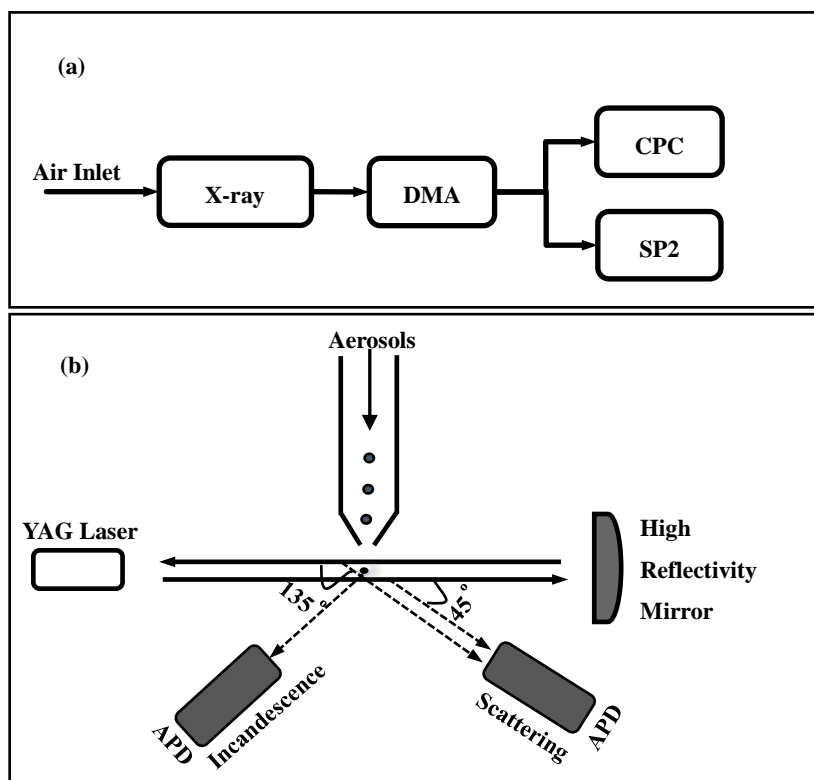

547 **Figure 1.** (a) Schematic of the measurement system. (b) Diagram of SP2 Chamber.

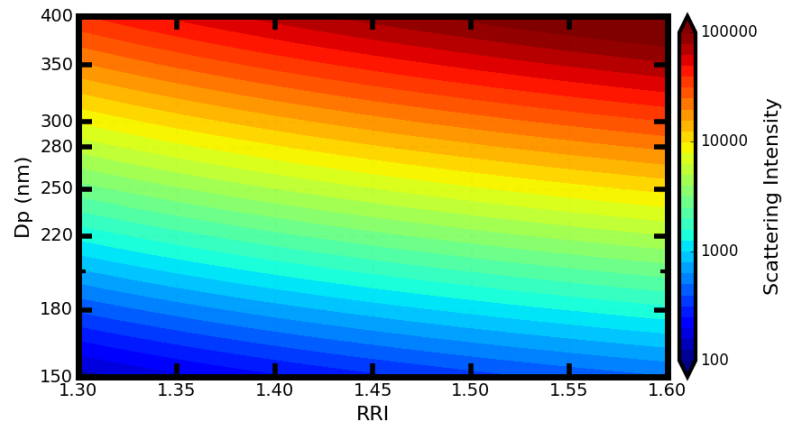

549 **Figure 2.** The distribution of the aerosols scattering intensity at different D_p and different RRI.

550

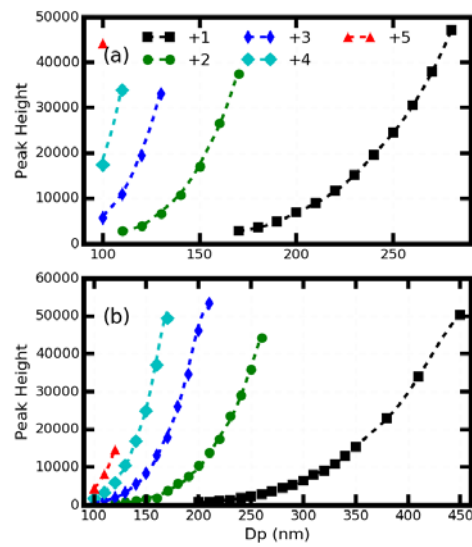

552 **Figure 3.** The geometric mean peak height for different diameters of the high gain channel. The
553 markers gives the measured values and the dotted line shows the theoretically calculated value.
554 Different colors represent the different number of elementary charges.

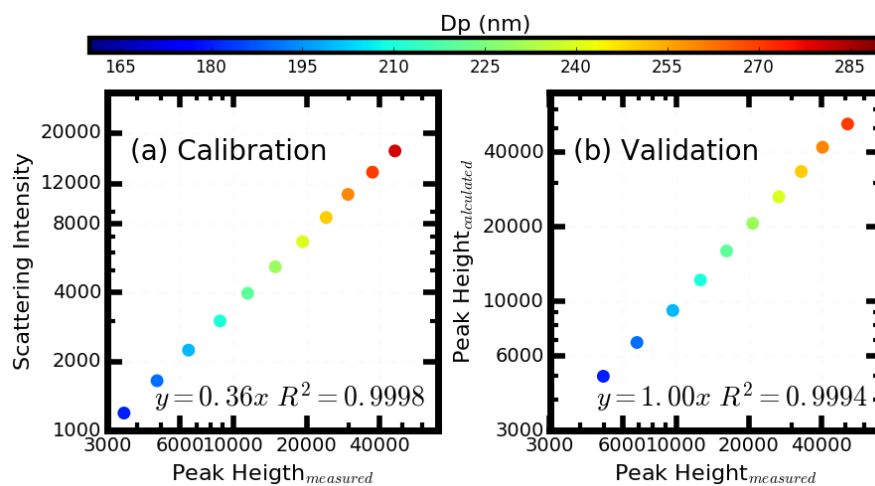

556

557 **Figure 4.** (a) the relationship between the scattering peak height from the SP2 high gain scattering
 558 channel when calibrating by using the ammonia sulfate and (b) the comparison between the measured
 559 scattering peak height from SP2 high gain scattering channel using the ammonia chloride and the
 560 calculated scattering peak height using the Mie scattering theory. Different colors represents the results
 561 at different diameters.

562

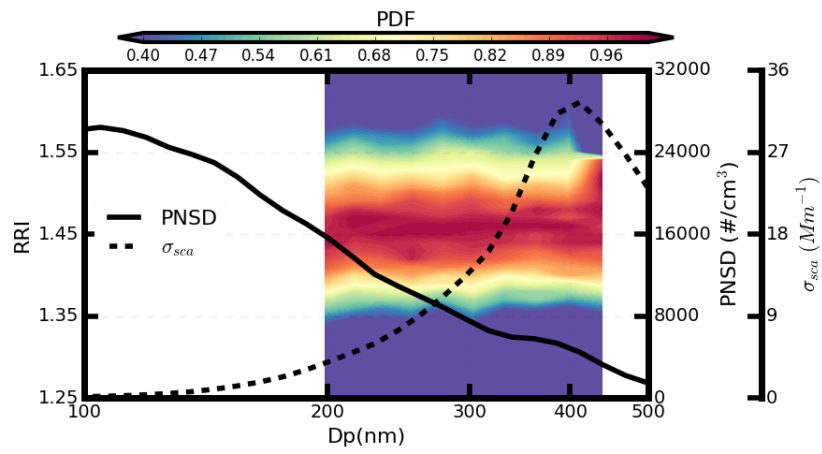

564 **Figure 5.** The measured probability of the size-resolved RRI (the filled color), the measured mean
 565 PNSD (the full line) and the mean scattering size distribution (the dotted line).

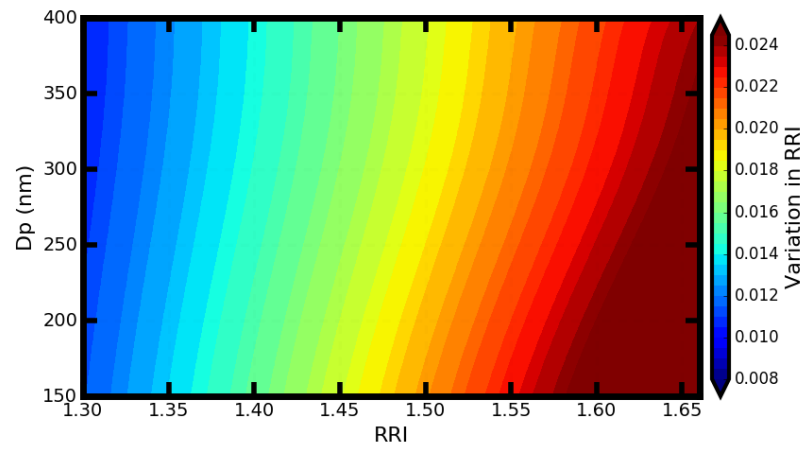

567 **Figure 6.** The variation in RRI for different kinds of aerosols that have different diameters and different
568 RRI.
569

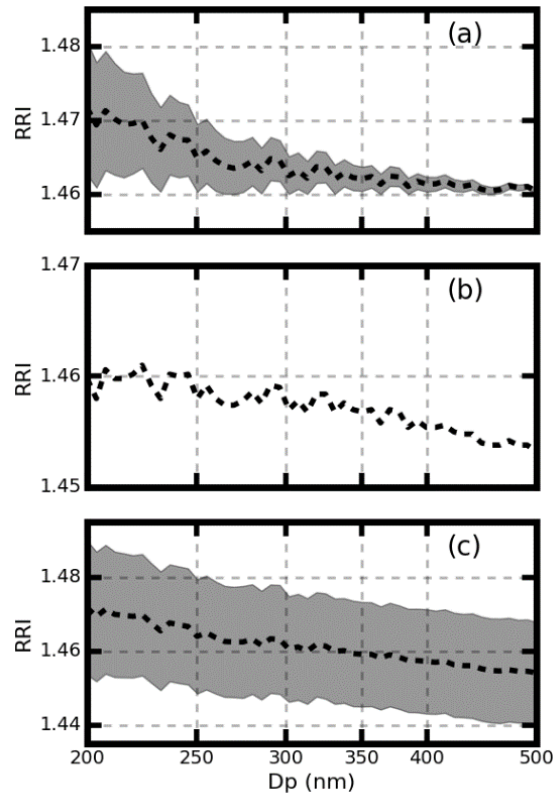

570

571 **Figure 7.** The retrieved aerosol RRI at different aerosol diameter. The filled color represents the 5th
572 and 95th percentiles.

573

574

575

576 **Table 1.** The retrieved RRI and the absolute difference between the retrieved RRI and the theoretical
577 RRI for different ammonia chloride diameters.

Dp(nm)	160	170	180	190	200	210	220	230	240	250	260	270
RRI	1.654	1.650	1.651	1.643	1.656	1.645	1.633	1.626	1.634	1.626	1.624	1.625
Difference	0.012	0.008	0.009	0.001	0.012	0.003	0.009	0.016	0.008	0.016	0.018	0.017

578