

Reply letter to the manuscript review by Anonymous Referee #3

We thank Anonymous Referee #3 for their perceptive and constructive review of our manuscript. Below, the Referee's comments (in bold) are followed by our response. Changes to the manuscript are highlighted in green.

Please note that, because we have moved a significant number of figures and tables to the Supplementary Materials, we have provided a list of the updated Figure, Table and Supplementary Material numbering at the end of this document.

Referee general comments and observations

The paper is a well designed experiment that investigate and compare the use, the performance, and the calibration of several instruments that measure N₂O isotopes using laser spectroscopy. Stable isotope measurements of atmospheric N₂O have largely increased in the last years due to the use and spread of these laser isotope analysers (from different manufacturers) in both field and lab conditions. However, it is sometimes unclear how the amount of data produced can be interpreted and compared among studies since several analytical issues has been raised. I believe this paper is timely and brings some light to many of these issues and will become a baseline text for people to get future directions into this fast-growing field. In general, I really enjoyed reading the paper since it is well written and the experimentation results are shown in an order manner. I only have some very minor comments for the authors to consider.

Specific

Referee Comment 1 – I noticed that in some places might be confusing if the authors do not specify that this is of direct application in atmospheric measurements. It is kind of obvious but when general conclusions are discussed like in Page 63 (L10-21), this will not hurt to make their statements clearer to the reader. I can easily think in other applications using laser spectrometers like the stable isotope measurement of dissolved nitrate, which is ultimately, transforms to N₂O for analysis. For instance, these applications have provided some approaches on the dependence of isotopic measurements on N₂O concentration; but as mentioned in the text, these might use standardized gas matrix for injection into the laser analyser.

Authors' response: We thank the Referee for their comment. Indeed, the discussion on P63 L10-21 is more applicable for atmospheric measurement applications, whereas applications like the analysis of $\delta^{15}\text{N}$ and $\delta^{18}\text{O}$ of N₂O derived from dissolved NO₃ are likely to substantially differ in the provided gas volumes and the ways the gases are introduced to the analyzers. The overarching aim of our study was to compare commercially available spectrometers that had not been modified with any additional add-ons. We acknowledge that accessory add-ons such as injection ports (Soto et al., 2015; Wassenaar et al., 2018) will likely be required for such applications, and this is mentioned in Sect. 4.3 Measurement workflow on P63 L24: "For specific applications, such as incubation experiments with He, accessory injection units and setups using TREX, related actions have to be taken.". We agree, however, that this could be made more obvious in the discussion:

*Please note that the following includes corrections implemented as part of our Reply to RC1 Comment 20.

P63 L11: “Researchers should also consider the sample gas volume required for a given measurement application using a specific laser spectrometer. In our experience, ensuring that five laser cavity cell volumes have been flushed prior to measurement is *best practice* to negate any memory effects when these instruments are operated using continuous flow-through configurations (as opposed to discrete sample measurements in a closed laser cavity). By following this procedure and using the operating parameters selected in this study (Table 1), the sample gas volume required for a single 300 s measurement is approximately 80 mL for CRDS II, 150 mL for CRDS I, 600 mL for OA-ICOS I and 1200 mL for QCLAS I. The different sample volumes required for CRDS I and CRDS II is due to the different selected flow rates. By comparison, TREX-QCLAS I requires approximately 5 L of sample gas to allow for N₂O pre-concentration. These sample gas volumes represent typical numbers for atmospheric applications; however, instrument parameter settings such as flow rate and cell pressure, which ultimately change the required sample volume, can be optimized depending on the measurement application. This is particularly the case for QCLAS instruments, which can be operated with different user-adjustable settings. For applications requiring discrete sample analysis (e.g. the headspace analysis of $\delta^{15}\text{N}$ and $\delta^{18}\text{O}$ in N₂O derived from dissolved NO₃⁻), high N₂O concentration gas samples with lower volumes can be introduced to these instruments using injection ports and dilution gases (e.g. Soto et al., 2015; Wassenaar et al., 2018); however we did not test these capabilities in our study. Thus, users should carefully consider the available volume of the sample gas, although the possibility exists to dilute high concentration samples to increase gas volume. Researchers should also ensure that gas samples contain N₂O within the operational ranges of the different laser spectrometers (Table 1).”

Referee Comment 2 – The main text is relative long and I hope the authors can move some details to the Supplementary Information.

Authors’ response: This was an overarching concern of all Referees. We have moved the following sections to the Supplementary Materials:

- Figure 7, 10 and 11 (Ar, CO, H₂O effects)
- Table 8
- Table 9
- Table 10
- P14 L25 (See our reply to RC1)
- P16 L4 (See our reply to RC1)

Technical corrections

Referee Comment 3 – Please explain the coefficients in Figure 1. (e.g. $\times 10^2$).

Authors’ response: The coefficients in Fig. 1 are included to ensure that the absorption lines can be viewed on the same scale within the figure, as not all interfering substances have

similar magnitudes of line strength within the wavelength regions of the different spectrometers. We will make the following addition to the Fig.1 caption:

Fig. 1. caption (P8 L3): “N₂O isotopocule absorption line positions in the wavenumber regions selected for A) OA-ICOS; B) CRDS; and C & D) QCLAS techniques. Regions of possible spectral overlap from interfering trace gases such as H₂O, CO₂, CH₄ and CO are shown. The abundance-scaled line strengths of trace gases have been scaled with 10⁻¹ to 10² (as indicated) because they are mostly weaker than those of the N₂O isotopocules.”

Referee Comment 4 – What is the carrier gas in Figure 2?

Authors’ response: We agree that the identity of the carrier gas may not be clear to the reader. We will therefore change “Carrier Gas” to “Matrix gas” in keeping with Table 2 which outlines their identity, and “S1-C_{90ppm}” to “High N₂O concentration reference gas” in keeping with Table 3. We intended the figure to represent the lab setup more generally, whereas Supplementary Material 2 (now Supplementary Material 3) provided the setup for each individual experiment. We will add the following to the Fig. 2 caption and updated the figure:

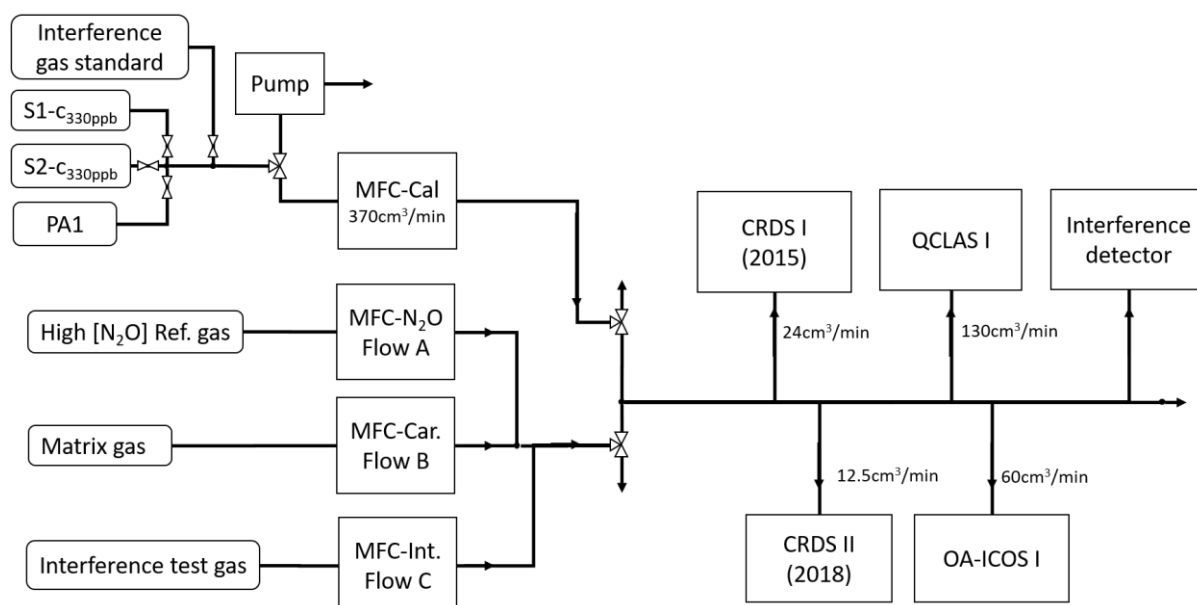

Fig. 2. Caption (P17 L9): “The generalized experimental setup used for all experiments conducted in this study. The gases introduced via MFC flows A, B and C were changed according to the experiments outlined in Sect. 2.4. Table 2 and Table 3 provide the composition of the *matrix gases* (MFC B), *interference test gases* (MFC C) and *high [N₂O] concentration reference gases* (MFC A). Laboratory setups for each individual experiment are provided in Supplementary Material 3.”

Referee Comment 5 – Suggest that the units in Table 6 are specified.

Authors’ response: We thank the referee for highlighting this. We will introduce the units in the first row.

Referee Comment 6 – It would be much easier to compare different laser spectrometers if the same scale is used for each parameter in Figure 4.

Authors' response: Although we agree that it would be interesting to compare the magnitude of these effects in the figure by using the same scale on the y-axis, the magnitude of the temperature dependence for QCLAS I renders it impossible to discern any of the same dependencies for the OA-ICOS I, CRDS I and CRDS II instruments because they are much smaller. For example, if we consider $\delta^{15}\text{N}^\alpha$ for all instruments in the figure below, as is presented in the current manuscript, there is a small, yet important, shift of up to $\sim 2\text{‰}$ for CRDS I and II:

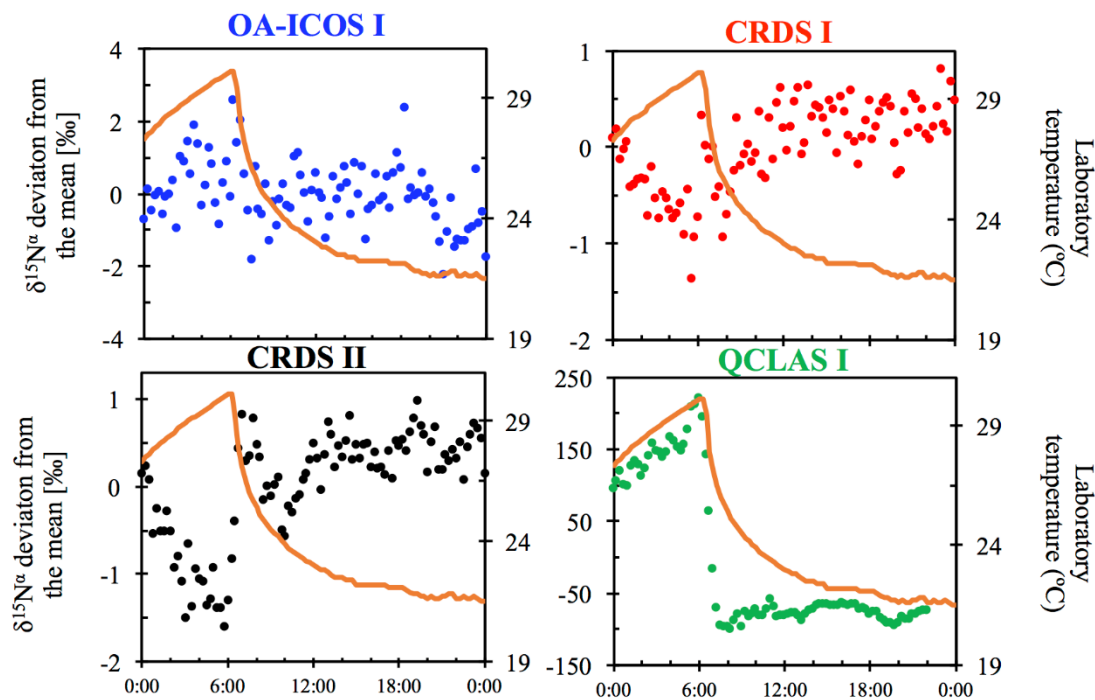

If the y-axis of this figure is then re-scaled to have the same y-axes, these small shifts are indiscernible:

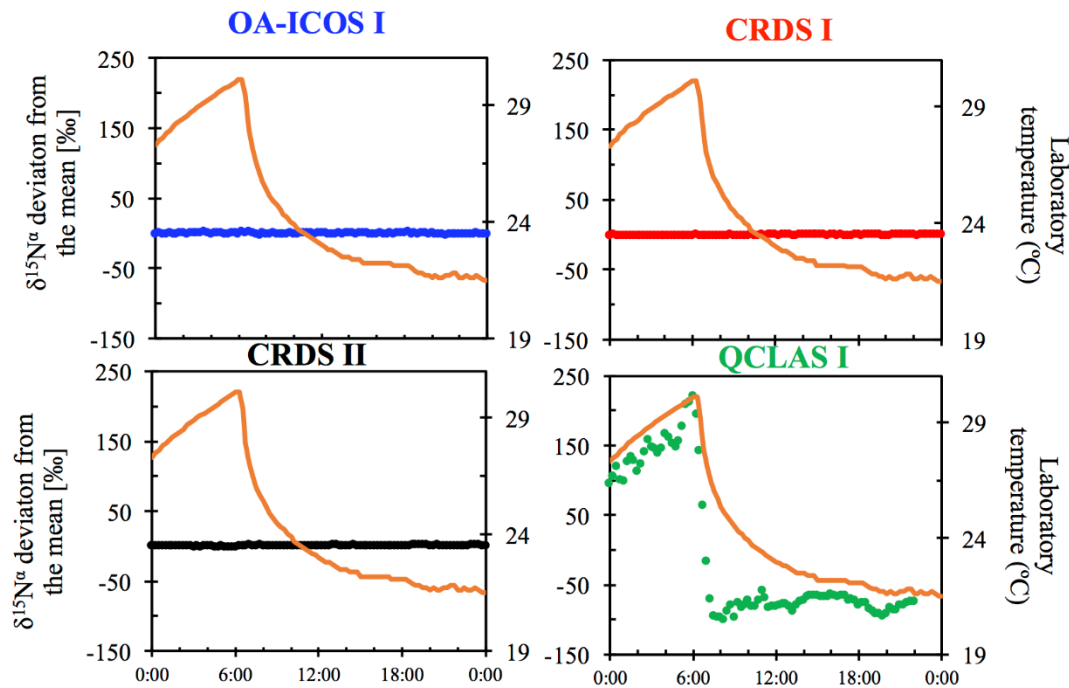

Unfortunately, this may prompt the reader into thinking that there is no significant effect, whereas that is not the case. Therefore, we will refrain from changing the y-axis on this figure. However, we will include a row in the new Table 8 (Summary Table as requested by Referee #1 and #2 which compares the various magnitude of temperature effects).

***Updated Figure numbering:**

- 1 – Isotopocule line positions and interferants
- 2 – Generalized experimental setup (updated)
- 3 – Allan deviation plots (updated)
- 4 – Temperature dependence plots (updated)
- 5 – Mole fraction dependence plots (updated)
- 6 – O₂ effects (updated)
- 7 – CO₂ effects (updated)
- 8 – CH₄ effects (updated)
- 9 – OA-ICOS I measured vs expected (updated)
- 10 – CRDS I measured vs expected (updated)
- 11 – CRDS II measured vs expected (updated)
- 12 – QCLAS I measured vs expected (updated)
- 13 – TREX-QCLAS I measured vs expected (updated)
- 14 – Source intercepts (updated)
- 15 – Measurement workflow (new)

***Updated Table numbering:**

- 1 – Instrument overview
- 2 – Matrix gases and interference test gases
- 3 – Reference gas compositions
- 4 – Overview of experiments
- 5 – Gas mixtures introduced for gas matrix and trace gas experiments

- 6 – Allan deviation
- 7 – Long-term repeatability
- 8 – Results summary (new)

***Updated Supplementary Materials numbering:**

- 1 – IRMS methodology
- 2 – Analysis of high [N₂O] isotope reference gases, ambient reference gasses, PA1 and PA2 (new)
- 3 – Experimental setups
- 4 – Complete datasets (new)
- 5 – Application of an automatic spectral correction method for QCLAS measurements
- 6 – Short-term repeatability
- 7 – Scaling of the signal-to-noise ratio
- 8 – Continuity of gas matrix and trace gas corrections at higher N₂O mole fractions
- 9 – Comparison with GC-IRMS
- 10 – Extrapolated source intercept values (new)
- 11 – Lower state energies of probed N₂O isotopocule lines (new)