

Interactive comment on “Development of a chemical ionization mass spectrometry system for measurement of atmospheric OH radical” by Wei Pu et al.

Wei Pu et al.

cetwang@polyu.edu.hk

Received and published: 16 October 2020

Dear Editor and Referees, Here is the plain text for our response. Please find the original document in the supplement section with color and Figures.

We appreciate all the comments and suggestions by the two referees which have enabled us to improve our manuscript. Please find our itemized responses below and corrections in the re-submitted files. The original comments are italic, and our responses are labeled by blue color, and the revised contents are shown in red color. The revised content in the manuscript will be highlighted.

C1

Anonymous Referee #1 Overall evaluation In this paper, a new Chemical Ionization Mass Spectrometer (CIMS) is described for the measurement of the important atmospheric radical, OH. The results described here are both novel and relevant to the atmospheric chemistry community. The authors describe how difficult this radical is to measure given its short atmospheric lifetime and thus, low concentration. However, due to its critical role in controlling the oxidizing capacity of the atmosphere, accurate quantification of this radical is needed in order to successfully evaluate our understanding of atmospheric chemistry. In situ field measurements of OH is relevant in its own right, but accurate assessments of OH these data are also very valuable in testing atmospheric trace gas models. In this work, the authors present a new CIMS system that is a welcome addition to the relatively few mass spectroscopy based instrumentation that has been used in the past to measure OH. The present the instrument as an alternative to the more common LIF systems that have been shown to have some drawbacks in accuracy and interference effects in certain environments that the authors describe. The paper is broken into two sections. The first is a rigorous evaluation of the performance, calibration, sensitivity and optimization of the new instrument in the lab and then second, the work describes a brief field deployment as a “proof of the instrumental concept” that has shown to provide data on the urban atmosphere in a Asian city. The authors report concentrations of OH typically found by other authors in similar environments and describe accuracy and uncertainties in these measurements that are again, typical of those found in the literature. Overall, I found the paper to had excellent technical description of the new CIMS instrument for the measurement of atmospheric OH concentrations and well worth of inclusion in AMT, pending a few small changes and or corrections/clarifications. Response: Thank you for the positive comments and encouragement.

Specific Comments or suggested corrections are listed as follows. Page 3, Line 11. The statement “third most important greenhouse gas” should include reference. Response: An IPCC report is added as a reference for this statement. Reference: Stocker, T. F., Qin, D., Plattner, G., Tignor, M., Allen, S. K., Boschung, J., Nauels,

C2

A., Xia, Y., Bex, V., and Midgley, P. (Eds.): IPCC 2013: summary for policymakers in climate change 2013: the physical science basis, contribution of working group I to the fifth assessment report of the intergovernmental panel on climate change, Cambridge University Press, Cambridge, New York, York, USA, 2013.

Page 3, Line 18. The word “enormous” seems unnecessary hyperbole, as does the word “huge” on Page 3, line 21. Response: We have changed the “enormous” and “huge” to “very” and “big”, respectively.

Page 8, Line 21. The authors describe sample air entering the system by way of a “blower”. I was confused as to the design of this blower. To me, a blower is a plumbing system that makes use of the fan which transfers the air in the emitted environment at high flow or low pressure. I assume the authors are referring to such a system and that its flow rate is regulated by the MFC they mention. I think a clarification of this inlet system would be warranted to describe the initial portion of the inlet more clearly. Response: Thank you for the suggestion. The blower we use here is exactly a plumbing system that transfers the air from the ambient to the front of the sample inlet. Most air in the tube is released back to the ambient. Only a small amount of the air flow from the center of tube flow is drawn into the CIMS by the sample inlet for further measurement (This small amount of flow in the sample inlet is controlled by MFC). Therefore, only high flow speed is required to reduce wall loss in the tube and the MFC is not needed for the blower. For clarification of the function of the blower, the description of the inlet system is modified as follows. Figure 1 also has some changes for the path of the sample air. Please note that the color of this figure is different from the one in the revised version in the manuscript to highlight the blower flow. Revised contents (Page 7):

“As shown in Figure 1, during OH measurements, air sample at ambient temperature and pressure is first drawn into a 5 cm diameter, 32 cm long stainless-steel tube. A turbulence-reducing scoop is attached to the front of the tube. The flow velocity at the center of the tube is 5 m/s, which is measured manually using a pitot. The central part

C3

of the air is then drawn through a 1.6 cm diameter stainless steel inlet into the chemical conversion region with the flow rate being determined by a mass flow controller (MKS, MFC company). The excess flow in the tube is vented back into the atmosphere via the inlet blower.”

Page 9, Line 5. The authors describe the distance of the injectors from “the tube”. Is this the front of the inlet scoop with the blower or the front of the ionization section of the instrument? Response: Thanks for pointing out the inaccuracy. It should be the inlet for the conversion region not “the tube” with the blower. We have changed “the tube” to “the stainless sample inlet” for a better understanding on page 7.

Page 18, Line 7. The sentence that “Coronal discharges are known to produce OH ions should include references.

Response: Thanks for the suggestion. A previous paper (Kukui et al. 2008) is added. Reference: Kukui, A., Ancellet, G. and Le Bras, G.: Chemical ionization mass spectrometer for measurements of OH and Peroxy radical concentrations in moderately polluted atmospheres, *J. Atmos. Chem.*, 61(2), 133–154, doi:10.1007/s10874-009-9130-9, 2008.

Page 19, Line 15. The authors describe the suppression of the instrument sensitivity by the addition of C3F6. Do the authors have any ideas as to why this was so? For the clarity of the paper and for attempts to replicate the results it would be helpful to expand this section with some suggested explanations of the effect of C3F6. Running a simple model of the ion chemistry could shed light on why there is such a suppression of the ion detection system. Response: Thanks for the suggestion. We re-examined the suppression problem and found that it was due to concurrent measurements of mass at 62 m/z and 64 m/z, the former of which saturated the aged detector. As shown in Figure S2 below, when the detector did not measure the 62 m/z mass, the addition of C3F6 only caused the 6 m/z signal to drop for a short time. In the revised manuscript, this new figure is used, and the corresponding discussion has been revised.

C4

Revised contents:

“Figure S2. Signal intensity at a) 62 m/z and b) 64 m/z for reagent ion detection by an aged detector when using C3F6 as OH scavenger. a) After the C3F6 suppression, the signal continuously decreases. b) the suppression recovers after time. It is noted that the scale in the y-axis of a) and b) are different.” In section 5.2 (Page 15-14): “For C3F6, although its OH removal efficiency was also high, it suppressed the signal intensities detected by the mass detector. This suppression recovered after a time when the detector was new (figure not shown). However, when the detector was aged, such suppression triggered a continuous decrease of the reagent signal as shown in Figure S2a. In this case, the change of reagent ions detection signal can avoid such a decrease (Figure S2b).”

Page 19, Section beginning at line 17. Although the addition of NO₂ to the system that the authors describe did effect both OH and HO₂ the absence of a higher concentration standard that those available to the authors make this section somewhat redundant. I feel removal of this discussion would not detract from the paper at all.

Response: Thanks for the comments, and we agree. The section of NO₂ has been removed.

Page 25, line 12. The authors describe the high background signal due to large concentrations of ambient H₂SO₄. Do they have any feel for what these ambient concentrations were (even ballpark)? Several studies suggest concentrations at sites typical to those the authors measured (e.g. Guo et al., 2012, Zheng et al. 2018) that could be described or at least referenced. Response: Thanks for the comment and suggestion of the references. The background signal in our instrument is the combination of H₂SO₄ in the ambient air and the instrumental noise. We calculated the H₂SO₄ signal by subtracting the instrumental noise from the total background, with the instrumental being determined by sampling the synthetic air. The ambient H₂SO₄ concentrations were estimated in the range of 2-8 x 10⁶ molecule/cm³. We could not find the suggested

C5

references because of the very common last names of Guo and Zheng. Revised contents (on Page 19): “The ambient H₂SO₄ concentration (10-sec average), which was estimated by the normalized background signal divided by the OH calibration factor, varied from 2.6 x 10⁵ in before sunrise to 8 x 10⁶ molecule/cm³ in mid-day (figure not shown).”

Page 26. The authors describe their future plans to reduce the interference of ambient H₂SO₄ by using isotopically labeled SO₂. This technique was first used by Eisele and Tanner (1991) and this line should thus reference this important earlier paper. Response: Thanks for the suggestion. the reference has been added as suggested. Reference: Eisele, F. L. and Tanner, D. J.: Ion-assisted tropospheric OH measurements, edited by Intergovernmental Panel on Climate Change, *J. Geophys. Res.*, 96(D5), 9295–9308, doi:10.1029/91JD00198, 1991.

Anonymous Referee #2 This paper describes the development of a chemical ionization mass spectrometer for the measurement of OH. The authors describe tests using ²¹⁰Po, and a corona discharge as ionization sources. They also describe tests using propane, C₃F₆, and NO₂ as different OH scavengers. The authors conclude that using the radioactive ²¹⁰Po and propane are the best ionization source and OH scavenger respectively. The authors also present a calibration system based upon water photolysis and N₂O actinometry. Overall, I find that there is little novel information presented and the work is not suitable for publication here. The CIMS technique described has been in use since the early 1990’s and the description are a rehash of the works published by Eisele, Tanner, Mauldin, Berresheim, Sjostedt, and others. The calibration is merely an adaptation of that used by Kürten et al. (2012). The stated limit of detection and uncertainty is approximately the same as reported in previous works. Response: Applying the CIMS technique to measure ambient OH has been a very challenging undertaking. Although its measurement principle was established some time ago, and several units of the CIMS have been developed in the world, but the technique is by no means mature. The detailed experimental procedures to make a CIMS functional for

C6

OH measurement have not been given in previous publications, nor provided with the commercially available CIMS. These have hindered the application of this technique to re-examine the missing OH source issue. To address this problem, we conducted comprehensive tests of a new CIMS, including a comparison of the different ion source and scavenger gas, optimization of sensitivity, and calibration. We believe that our article reporting the detailed experimental results will fill the gap of the missing technical knowledge, and will be useful for the new development/applications of CIMS for measurement of OH and other chemicals. We have shortened descriptions of the basic theory of the OH-CIMS and calibration and emphasize the optimization parts.

I find that the present work also lacks detail when compared to the previous works. For example, there are no concentrations of reagent gases given, only flows. Response: We have added relevant concentrations. The concentration of SO₂ and propane in the sample flow is 12 ppm and 535 ppm, respectively. The concentration of the reagent gas (HNO₃) is not measured; however, its exact concentration is not required in the measurement. Instead, the ratio of NO₃⁻ and HSO₄⁻ needs to be measured and used in equation 2 shown on the manuscript to derive OH concentration. We added a short discussion on the necessity of the absolute concentration for reagent gases. Revised content on Page 8: "As discussed in Berresheim et al. (2000), the absolute concentration of the H₂SO₄ and reagent ion (NO₃⁻) is not required as the OH concentration is determined based on their relative signal strength and the calibration factor." Reference: Berresheim, H., Elste, T., Plass-Dülmer, C., Eisele, F. L. and Tanner, D. J.: Chemical ionization mass spectrometer for long-term measurements of atmospheric OH and H₂SO₄, *Int. J. Mass Spectrom.*, 202(1–3), 91–109, doi:10.1016/S1387-3806(00)00233-5, 2000.

Many of the tests performed (varying lens voltages, SO₂ and scavenger flows etc.) are specific to the geometry of a particular CIMS system and are typical tests to characterize the instrument and establish operational parameters. Response: We agree with the above comments. However, as we responded to a previous comment, none of

C7

the previous papers have detailed descriptions of systematic tests for the optimization of the CIMS. We believe such test procedures and results are helpful for new CIMS developer/operator. Although the set-up parameters are specific to our CIMS unit, the general procedures are applicable to other CIMS. To make our work more applicable to other CIMS, we have added some rationales behind the various tests and rearranged the section. Revised contents in Section 5.4. Instrument sensitivity and noise (Start from Page 15): The sensitivity (S) of the CIMS instrument to the OH radicals depends on the reaction efficiency of OH and SO₂ in the chemical conversion region (f(CE)), the conversion efficiency of H₂SO₄ to HSO₄⁻ in chemical ionization region (f(IE)), and the transmitted efficiency of HSO₄⁻ from sample inlet to the mass spectrometer system (f(TE)): $S \sim f(CE) \cdot f(IE) \cdot f(TE)$

f(CE) is dependent on the reaction time and the SO₂ concentration of the conversion reactions (R1-3). f(IE) is affected by the flow dynamics, which determines the mixing of flows, and the electric field inside the ionization region, which forces the NO₃⁻·(HNO₃)_m·(HO₂)_n primary ions to the center of the region for H₂SO₄ ionization. The f(CE) is related to the N₂ buffer and induces an electric field in the pinhole area. In this work, the f(CE) is first optimized for the maximum conversion of the ambient OH to H₂SO₄ by adjusting the SO₂ flow and the sample flow rate. Then, to achieve the best f(IE) for H₂SO₄ ionization, the flow dynamic and electric field are optimized by adjusting the sample/sheath flow ratio and the voltages applied to sample and sheath flow. Finally, the N₂ buffer flow rate and the voltages of the pinhole are adjusted to control the f(TE) to determine the amounts of ions entering the detector. During the optimization, the calibration tube is applied to produce OH radicals and control its concentration. 5.4.2 Conversion efficiency Figure 5a shows the normalized signal intensity (NSI) at 97 m/z for HSO₄⁻ as a function of the flow rate of SO₂ (0.9 vol.%). The NSI first increased with increased SO₂ and reached a stable level at a flow rate > ~2.5 sccm, which did not vary with the relative humidity. This result indicates that the SO₂ concentration at the flow rate of 2.5 sccm was adequate to convert sampled OH to H₂SO₄. Since the concentration of OH radicals produced by the calibration

C8

unit during optimization was 1 to 2 magnitude higher than in that in ambient condition, the 2.5 sccm flow of SO₂ is adequate for ambient measurement. We set the SO₂ flow rate at 5 sccm with a factor of 2 margins, following the previous study (Sjostedt et al., 2007). With this flow rate, the concentration of SO₂ in the sample flow is 12 ppm. The effects of the sample flow rate on NSI are shown in Figure 5b. During adjusting the sample flow rate, if the sheath flow rate remains the same, the conversion time and the flow dynamics will be affected. Thus, in order to show the effect of conversion time to NSI only, the sheath flow was adjusted along with the sample flow to maintain the sample/sheath flow ratios and control the f(IE) in Figure 5b. Briefly, the NSI increased with the decrease of sample flow rate, which can be explained by a longer OH conversion time (R1-3) and a higher f(CE) at a lower flow rate. However, the increased reaction time will also increase the OH interference produced from HO₂ recycling in the presence of NO in sample air. Previous studies usually kept the reaction time less than 60 ms to mitigate such interference (e.g. Tanner et al., 1997). After considering the reaction time and interference, the sample flow rate was set at 3.7 slpm, which gives a reaction time of ~47 ms. After the above selection of the SO₂ concentration and sample flow rate, the optimal f(CE) is determined.

5.4.3 Ionization efficiency Figure 5c shows the NSI as a function of the ratio of sample flow to sheath flow in the ionization region. The NSI firstly increased and then decreased with the increased ratio, with a peak value at a sample/sheath flow ratio of 0.3. This optimized ratio was independent of the total flow rates from 12 to 21 slpm. This ratio produced a turbulent flow in the chemical ionization region. Such flow dynamics facilitates a fast mixing of the reactants and enhances the f(IE) of H₂SO₄ as well as the NSI at 97 m/z (Tanner and Eisele, 1995; Tanner et al., 1997). Figure 5d-e shows the effects of voltages applied to the sample and sheath flow on NSI. The NSI first increased and then decreased as the increase of difference in voltage between the sample and sheath flow (figure 5d). At the voltage difference of 48 V, the peak NSI was achieved, and this voltage difference is selected. Figure 5e shows the NSI increased with the negative sheath voltage and then kept stable with sheath voltage < -70V. This shows that when it is negatively charged, it

C9

is the voltage difference but not the exact voltage that affects the NSI. In our studies, we set the inlet and sheath voltages at -32 and -80 V, respectively. The cross interactions of sample/sheath flow and voltages on NSI were also evaluated (see Figure S3). The result shows that the highest NSI was achieved when the sample/sheath flow ratio was close to 0.3, independent of the voltages. The optimized f(IE) of the CIMS is achieved by the above selections of the flow ratio and electric field.

5.4.4 Transmission efficiency The N₂ buffer flow rate controls the proportion of sample air in dry N₂ (refer to figure 1), thereby affecting the amount of ion clusters in the sample air entering the mass detector. Figure 5f shows that the NSI increased with the decreased buffer flow rate, as expected. However, a lower flow rate of N₂ buffer gas also allows more undesired neutral molecules and particles in sample air to enter the mass spectrometer (Berresheim et al., 2000). With these considerations, the flow rate of N₂ buffer gas was set as 440 sccm. To force the ions to the center of the pinhole, the voltage applied to before and on the pinhole was set at -70V and -40V, respectively.

5.4.5 Noise minimization After the optimization of CIMS's sensitivity, noise minimization is needed to reduce the signal that is not related to the ambient OH concentration. As discussed above, the noises for OH measurements include H₂SO₄ in ambient air and artificial OH produced by the ion source. These noises can be mitigated by adding a scavenger gas in the sheath flow to eliminate artificial OH and in the sample flow to quantify ambient H₂SO₄ (Figure 1). Below we determine the optimal flow rates for the scavenger gas. Figure 6 shows the HSO₄- signal intensity as a function of propane flow rates in sheath flow, with N₂ gas as the sample air. When propane was not added, the artificial OH concentration from the 210Po ion source was $\sim 3.5 \times 10^6$ molecules cm⁻³, which is comparable to the typical OH concentrations in ambient environments. When propane was added into the sheath gas, the artificial signals were reduced with the increasing propane flow and kept stable at $\sim 1 \times 10^6$ molecules cm⁻³ when the flow rate was higher than 1 sccm. We thus set a flow rate of 2 sccm for propane in the sheath flow. Figure 7 shows the removal efficiency (RE) of OH by propane added in the sample flow as a function of the propane flow rates. The OH radicals were produced by the calibration unit described

C10

in Section 4.2. The RE increased with the increased propane flow rate initially and leveled off at the flow rate > 1 sccm. We adopt the flow rate of propane of 2 sccm (~535 ppm), which led to ~98% removal efficiency for OH. As OH concentrations in this test are much higher than those in typical ambient air, the RE of the propane for ambient OH should be even large at the selected flow rate.

The tests of the different ionization sources and OH scavengers are interesting but have little significance when compared to the rest of this work. On the other hand, a manuscript with some brief descriptions of the measurement techniques and in-depth data analysis of the field measurements would be much stronger and would be of great interest, but will be more suitable for a more general journal (not an instrumentation journal).

Response: As responded to the previous comments, the descriptions of comprehensive tests on OH scavengers (and other components) have not been given in previous studies, and we believe that they are helpful to new CIMS users and decide to keep them. The NO₂ section has been deleted in response to the first reviewer's comment.

Specific questions/comments: There are many grammatical errors in the manuscript that make it not suitable for publication. Response: Thanks for the comment, the manuscript has been carefully revised to eliminate the grammatical errors.

The words titrate and titration are used throughout the manuscript. Titrate and titration are chemistry terms that indicate the smallest amount of reagent necessary to reach an endpoint. The term convert and conversion are more accurate. Response: Thanks for the comment on specific term use. The words titrate and titration has been widely used in previous CIMS articles for the same purpose. (Muller et al., 2018; Tanner et al., 1997; Berresheim et al., 2003; Kukui et al., 2014; Mauldin et al., 1999; Acker et al., 2006) However, after considering the meaning of "titrate" and "titration" provided by the reviewer, we agree it is better to use "convert" instead of "titrate". And the "titration efficiency" was also changed to the "conversion efficiency".

C11

No mention is made of the distribution of nitrate ions and clusters. Is this distribution measured? It is shown in Figure 1 that HNO₃ is added to the rear injector flow (as in Sjostedt et al. and references therein) in addition to that added to the sheath gas to maintain the HNO₃ cluster distribution in the instrument. There is no mention of this aspect in the text. Does the cluster distribution change over time or even between operating modes (OH signal and background)? Does that affect the sensitivity?

Response: Thanks for pointing out the rear HNO₃. We have added a description of the rear HNO₃. The change of mode will not affect the concentration of HNO₃ in the system because the HNO₃ is added from the rear injector continuously in both modes, and the pulsed flow of scavenger is compensated by the nitrogen gas at the same flow rate. Thus, the sensitivity will not be affected. Addition Content in Section 3.1.2 Chemical ionization region (Page 8): "Additionally, the N₂ carried HNO₃ is also added through the rear injector to maintain the ion cluster distribution and further improve the stability of the reagent ion signal (Sjostedt et al., 2007)."

It is stated that the OH background measurement is made to account for pre-existing ambient H₂SO₄. Is this the only source of the background signal? A publication in Nature by Mauldin et al. states that a significant fraction of this OH background signal caused by a non-OH oxidant of SO₂ in environments with large biogenic emissions. Could such emissions affect the sensitivity?

Response: The suggested Nature article described a possible source for H₂SO₄ from the stabilized Criegee intermediate or its derivatives which are linked to the presence of alkenes or biogenic origin. However, the field measurement presented by our manuscript was done on the 11th floor (50 m above the ground) next to the highway. In this case, the biogenic emissions are relatively low compare to anthropogenic emission. Therefore, the H₂SO₄ signal in our manuscript is mostly caused by the anthropogenic emission.

Please also note the supplement to this comment:

C12

C13

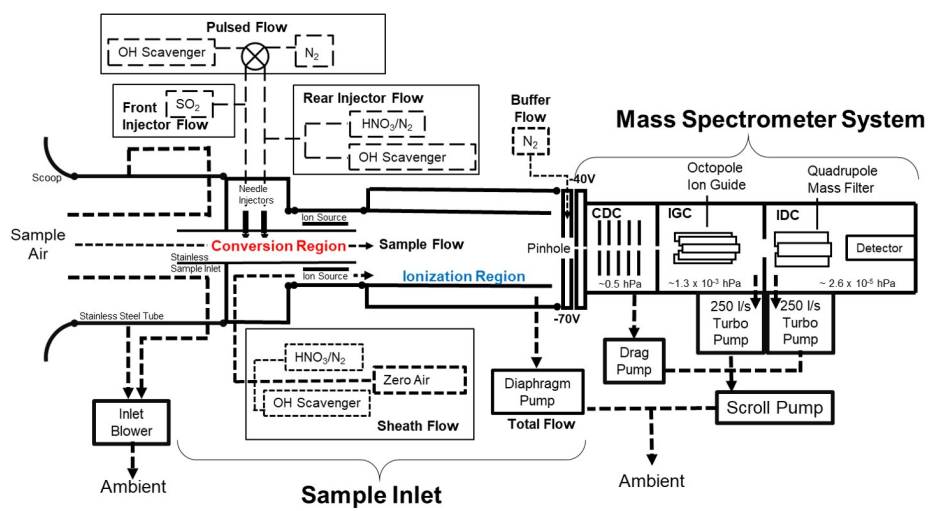

Fig. 1. Figure 1

C14

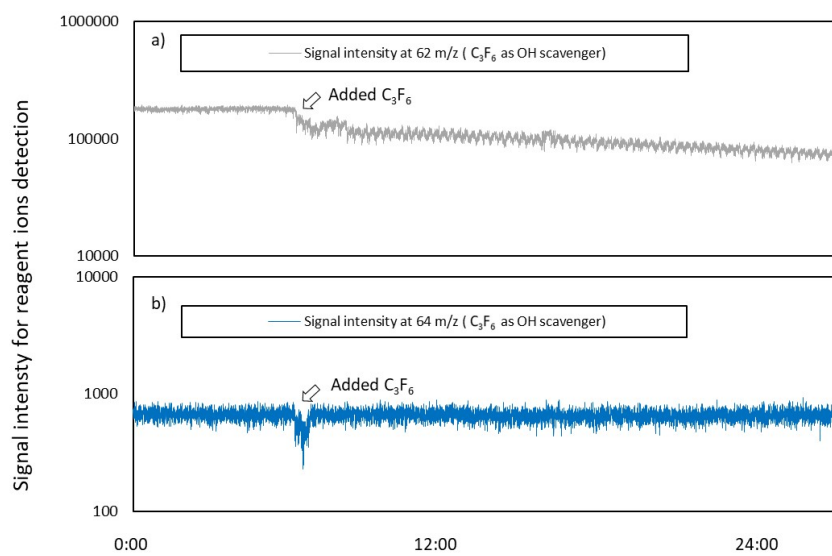

Fig. 2. Figure S2