



# IRIS analyser assessment reveals sub-hourly variability of isotope ratios in carbon dioxide at Baring Head, New Zealand's atmospheric observatory in the Southern Ocean

5 Peter Sperlich<sup>1</sup>, Gordon W. Brailsford<sup>1</sup>, Rowena C. Moss<sup>1</sup>, John McGregor<sup>1</sup>, Ross J. Martin<sup>1</sup>,  
Sylvia Nichol<sup>1</sup>, Sara Mikaloff-Fletcher<sup>1</sup>, Beata Bukosa<sup>1</sup>, Magda Mandic<sup>2</sup>, Ian Schipper<sup>3</sup>, Paul Krummel<sup>4</sup>

<sup>1</sup>National Institute of Water and Atmospheric Research (NIWA), Wellington, New Zealand

<sup>2</sup>Thermo Fisher Science, Bremen, Germany

<sup>3</sup>Victoria University of Wellington, New Zealand

<sup>4</sup>Commonwealth Scientific and Industrial Research Organisation (CSIRO), Aspendale, Australia

10 *Correspondence to:* Peter Sperlich (peter.sperlich@niwa.co.nz)

**Abstract.** We assess the performance of an Isotope Ratio Infrared Spectrometer (IRIS) to measure carbon ( $\delta^{13}\text{C}$ ) and oxygen ( $\delta^{18}\text{O}$ ) isotope ratios in atmospheric carbon dioxide ( $\text{CO}_2$ ) and report observations from a 26 day field deployment trial at Baring Head, New Zealand, NIWA's atmospheric observatory for Southern Ocean baseline air. Our study describes an operational method to improve the performance in comparison to previous publications on this analytical technique. By using a calibration technique that reflected the principle of identical treatment of sample and reference gases, we achieved a reproducibility of 0.07 ‰ for  $\delta^{13}\text{C}\text{-CO}_2$  and 0.06 ‰ for  $\delta^{18}\text{O}\text{-CO}_2$  over multiple days. This performance is within the “extended compatibility goal” of 0.1 ‰ for both  $\delta^{13}\text{C}\text{-CO}_2$  and  $\delta^{18}\text{O}\text{-CO}_2$ , which was recommended by the World Meteorological Organisation (WMO) for studies of regional or urban  $\text{CO}_2$  fluxes. One goal of this study was to assess the capabilities and limitations of the IRIS analyser to resolve  $\delta^{13}\text{C}\text{-CO}_2$  and  $\delta^{18}\text{O}\text{-CO}_2$  variations under field conditions. Therefore, we selected multiple events within the 26 day record for Keeling Plot Analysis. This resolved the isotopic composition of end members with an uncertainty of  $\leq 1$  ‰ when the magnitude of  $\text{CO}_2$  signals is larger than 10 ppm. The uncertainty of the Keeling Plot Analysis strongly increased for smaller  $\text{CO}_2$  events (2-7 ppm), where the instrument performance is the limiting factor and may only allow for the distinction between very different end members, such as the role of terrestrial versus oceanic carbon cycle processes. Further improvement in measurement performance is desirable to meet the WMO “network compatibility goal” of 0.01 ‰ for  $\delta^{13}\text{C}\text{-CO}_2$  and 0.05 ‰ for  $\delta^{18}\text{O}\text{-CO}_2$ , which is needed to resolve the small variability that is typical for background air observatories such as Baring Head.

30



## 1. Introduction

Carbon dioxide (CO<sub>2</sub>) is the single most important anthropogenic greenhouse gas, and it is therefore of critical importance to understand biogeochemical processes controlling atmospheric CO<sub>2</sub> levels (IPCC 2021). The isotopic composition of atmospheric CO<sub>2</sub> at any time and location is controlled by different carbon cycle processes and can therefore be used to constrain carbon fluxes on a range of spatio-temporal scales. For example, Ciais et al. (1995a; 1995b) have used stable carbon isotope ratio in atmospheric CO<sub>2</sub> ( $\delta^{13}\text{C-CO}_2$ ) in weekly samples from 43 sites to distinguish terrestrial and ocean sink fluxes. Keeling et al. (2017) also used  $\delta^{13}\text{C-CO}_2$  from flask samples to infer changes in water use efficiency of plants with increasing atmospheric CO<sub>2</sub> mole fractions. Similarly, the oxygen isotope ratio ratios in CO<sub>2</sub> ( $\delta^{18}\text{O-CO}_2$ ) have been used as a tracer for gross primary production (GPP) of the terrestrial biosphere (Francey and Tans, 1987; Ciais et al., 1997). Using global  $\delta^{18}\text{O-CO}_2$  records, Welp et al. (2011) demonstrated the impact of El Niño Southern Oscillation on the global carbon cycle and provided revised GPP estimates that exceeded previous values by ~30 %. Much of the knowledge on isotope ratios in atmospheric CO<sub>2</sub> has been generated by isotope ratio mass spectrometry (IRMS) measurements in discrete air samples (Ferretti et al., 2000; Werner et al., 2001; Allison and Francey, 2007; Brand et al., 2016), often requiring a complex and well operated logistical network (Ciais et al., 1995a; Welp et al., 2011; Keeling et al., 2017). This may be particularly challenging for tracers such as  $\delta^{18}\text{O-CO}_2$ , which can be subject to storage effects in flasks (Rothe et al., 2005; Vardag et al., 2015).

The potential for field-deployable, laser-based instruments measuring both mole fractions and isotope ratios in atmospheric CO<sub>2</sub> in real-time has been demonstrated (Bowling et al., 2003; Mohn et al., 2007). Continuous technical improvement of both analysers and applied calibration techniques enables an achievable measurement precision that is increasingly comparable to that of well-performing IRMS systems (Tuzson et al., 2011; Griffith et al., 2012; Sturm et al., 2013; Hammer et al., 2013; Flores et al., 2017; Pieber et al., 2021) and is approaching the compatibility goal of the World Meteorological Organisation (WMO), (Steur et al., 2021). With that, laser-based instruments may be an interesting alternative for observations that were previously limited to IRMS laboratories and flask sampling programmes. The performance of these techniques was demonstrated in the monitoring of annual and seasonal cycles with high temporal resolution (Sturm et al., 2013; Vardag et al., 2016; Pieber et al., 2021). Moreover, real-time measurements of CO<sub>2</sub> and its stable isotopes opens new research opportunities that researchers have hitherto not been able to explore. For example, the high temporal resolution achievable with laser-based instruments enables observations ranging from synoptic scales (Vardag et al., 2015; Vardag et al., 2016; Pieber et al., 2021) to that of micrometeorological observations (Griffis et al., 2008; Wehr et al., 2013), for which IRMS based techniques are not a feasible long-term solution.

Commercially available instruments show a large variability in their performance (i.e. achievable measurement precision) and in the level of operator knowledge and interaction required to make meaningful measurements. Key questions are how the achievable instrument performance for each of these instruments compares to traditional IRMS techniques and other laser-based instruments, and what new research opportunities these techniques may provide.



In this study, we assess the performance of an IRIS analyser, the “Delta Ray”, manufactured by Thermo (Thermo Fisher Scientific, Bremen, Germany). Note that Thermo has discontinued the manufacturing of the Delta Ray since the experiments of this study were completed. The first studies that deployed the then new Delta Ray instrument in the field have demonstrated its capability to resolve variation ranges in both CO<sub>2</sub> mole fractions (101-103 ppm) and isotope ratios (1-15 ‰). These studies included CO<sub>2</sub> observations i) at carbon storage and sequestration sites (Van Geldern et al., 2014), ii) of volcanic CO<sub>2</sub> emissions (Rizzo et al., 2014; Schipper et al., 2017), iii) at a forest site (Braden-Behrens et al., 2017), and iv) in a cave system (Töchterle et al., 2017). Both Van Geldern et al. (2014) and Braden-Behrens et al. (2017) report Allan deviations for  $\delta^{13}\text{C}\text{-CO}_2$  of around 0.04 and 0.02 ‰, respectively. However, both publications also report final measurement uncertainties of their field deployed instruments of 0.3 ‰. Töchterle et al. (2017) and Flores et al. (2017) report uncertainties of 0.34 ‰ and 0.18 ‰ for  $\delta^{13}\text{C}\text{-CO}_2$  and 0.44 ‰ and 0.48 ‰ for  $\delta^{18}\text{O}\text{-CO}_2$ , respectively. Only Rizzo et al. (2014) reports a precision that is close to the values of reported Allan Deviations with <0.05 ‰. Altogether, these studies reveal a significant difference between Allan Deviation and the reported measurement uncertainties, suggesting that the latter may be improved significantly. Achieving uncertainties closer to the compatibility goals of the WMO (WMO-GAW, 2019) potentially increases the variety of research questions this instrument may help to answer.

We tested the Delta Ray instrument in our laboratory and at Baring Head (BHD), our observatory for Southern Ocean background air (Brailsford et al., 2012). Generally, Southern Ocean background air shows very little variability in CO<sub>2</sub> mole fractions (Stephens et al., 2013; Steinkamp et al., 2017) and isotope ratios (Allison and Francey, 2007; Moss et al., 2018), providing one of the most challenging environments to explore the performance of a field-deployed instrument for such measurements (Pieber et al., 2021). We compare Delta Ray data with co-located observations of CO<sub>2</sub> mole fractions in the context of meteorology and the variability of Radon. Due to the unfortunate failure of the automated air sampler at BHD during the time of the Delta Ray deployment, we cannot provide a direct comparison of the Delta Ray and our well-established GC-IRMS system (Ferretti et al., 2000; Moss et al., 2018). However, we compare the Delta Ray data from background air events with interpolated  $\delta^{13}\text{C}\text{-CO}_2$  and  $\delta^{18}\text{O}\text{-CO}_2$  observations from BHD and the Cape Grim Observatory (CGO). Despite the limitation to resolve the isotope variability of the smallest CO<sub>2</sub> signals (i.e. CO<sub>2</sub> variability  $\leq 2$  ppm), the Delta Ray time series provides valuable information on the processes controlling the variability of CO<sub>2</sub> at BHD on synoptic and daily time scales.

## 90 2. Methods

We tested the Delta Ray instrument in two separate campaigns. An early Delta Ray model was used during 2015 in NIWA’s atmospheric laboratory for Allan Deviation and stability tests, as well as during the deployment at the BHD observatory. In 2018, we used a factory-refurbished Delta Ray model with improved precision. This instrument was used for CO<sub>2</sub>-free air experiments before it developed faulty behaviour and had to be returned to Thermo without deployment at BHD.

95



## 2.1 The Delta Ray analyser

The physical principle of the Delta Ray has been described in detail in previous publications (Van Geldern et al., 2014; Töchterle et al., 2017; Braden-Behrens et al., 2017). In short, the instrument measures the absorption spectrum of CO<sub>2</sub> in the mid-infrared range. It comprises of two units, the analyser and the Universal Reference Interface (URI). The URI dilutes isotopically known, pure CO<sub>2</sub> gases with CO<sub>2</sub>-free air and supplies this mixture as reference gas to the laser unit. The operating software (Qtegra) controls the CO<sub>2</sub> mole fraction in the reference gas by matching the average mole fraction of a previously measured sample. This concept is applied to account for the CO<sub>2</sub> amount effect on the measured isotopic composition of the analyser (Braden-Behrens et al., 2017). The software calculates the isotopic composition of the unknown samples using the isotope values of the two pure CO<sub>2</sub> gases. This two-point calibration also accounts for the so-called “scale-compression”. Furthermore, the system requires an air standard with known CO<sub>2</sub> mole fractions to calibrate the mole fraction measurements of the Delta Ray. Once all gases are connected and the Delta Ray at operating temperature, the instrument requires a calibration procedure to determine factors for linearity, scale compression, isotope calibration, mole fraction calibration and for the mass flow controller that mixes pure CO<sub>2</sub> with the carrier gas. Qtegra applies these factors to all following sample measurements. Thermo specifies the achievable instrument precision to be 0.07 ppm for CO<sub>2</sub> mole fractions and as low as 0.05 ‰ for both  $\delta^{13}\text{C-CO}_2$  and  $\delta^{18}\text{O-CO}_2$  (Thermo, 2014).

## 2.2 Reference gases, quality control gases and carrier gases

Two electropolished 1 L stainless steel flasks were filled to 5 bar with two pure, isotopically distinct CO<sub>2</sub> gases, referred to as Marsden and Kapuni. We determined  $\delta^{13}\text{C-CO}_2$  and  $\delta^{18}\text{O-CO}_2$  values of  $-32.77$  ‰ and of  $-32.52$  ‰ for Marsden, and of  $-13.75$  ‰ and of  $-11.69$  ‰ for Kapuni, respectively (Table 1), using a dual inlet IRMS system and VPDB scale realisation described by Lowe et al. (1994). Over all experiments, we re-filled the flasks with Marsden and Kapuni following the same filling protocol but did not re-calibrate the aliquots. Thereby, we assign a conservative uncertainty of 0.1 ‰ to the isotope values used for both gases (Table 1). While the isotopic difference between Marsden and Kapuni is in the range of the reference gases that Thermo supplies commercially for that purpose (“Ambient” and “Bio”), typical values of atmospheric CO<sub>2</sub> are outside the range covered by our two gases. Due to its isotopic proximity to that of atmospheric CO<sub>2</sub>, we used Kapuni as the regularly used reference gas (Ref-1) during all measurements, while Marsden was only used during the initial instrument calibration (Ref-2).

We used a CO<sub>2</sub>-free air from Scott-Marrin (Scott-Marrin, California, USA, now Praxair, USA) as carrier gas in the 2015 campaign. Scott-Marrin produces their CO<sub>2</sub>-free air by purifying natural air (Scott-Marrin, Lori Thomas, pers. comm, via email on 16 August 2014) and certifies the CO<sub>2</sub>-free air with  $<1$  ppm CO<sub>2</sub>, which exceeded the recommended level of  $<0.5$  ppm (Thermo, 2014). To test the effect of different carrier gases on the measured isotopic compositions, we applied a range of CO<sub>2</sub>-free gases in the 2018 campaign (section 3).



As calibration gas for CO<sub>2</sub> mole fractions, we used a 30 L Luxfer cylinder (Scott-Marrin, California, USA, now Praxair, USA) with compressed natural air, taken at BHD. The CO<sub>2</sub> mole fraction was determined by gas chromatography (GC) at NIWA's atmospheric laboratory.

Furthermore, we used five 30 L Luxfer cylinders with compressed air as quality-control gases (referred to as QC-1 to QC-5). The  $\delta^{13}\text{C}\text{-CO}_2$  and  $\delta^{18}\text{O}\text{-CO}_2$  isotope ratios of the QC gases were measured on NIWA's gas chromatography isotope ratio mass spectrometer (GC-IRMS) system, (Ferretti et al., 2000; Moss et al., 2018), using a custom made peripheral on a MAT252 isotope ratio mass spectrometer (Thermo Finnigan, Germany). The instrument is calibrated using a propagated VPDB-CO<sub>2</sub> scale realisation from the Commonwealth Scientific and Industrial Research Organisation (CSIRO, Aspendale, Australia). Two QC gases were included in each measurement cycle. CO<sub>2</sub> mole fractions in QC-1 to QC-3 were determined using a gas chromatograph system at NIWA's gaslab, while mole fractions of QC-4 and QC-5 were measured using the Picarro system at BHD and via comparison of peak sizes on the GC-IRMS instrument, respectively. CO<sub>2</sub> mole fractions in QC-1 to QC-4 are calibrated to the WMO CO<sub>2</sub> X2007 scale.

140

### 2.3 Calibration scheme

Thermo designed an integrated referencing technique for the Delta Ray, in which two pure CO<sub>2</sub> gases with known isotopic composition get diluted with CO<sub>2</sub>-free air to match CO<sub>2</sub> mole fraction range of measured air samples. Therein, the system attempts to conserve the isotopic composition of the pure CO<sub>2</sub> during the dilution process and to provide a CO<sub>2</sub>-in-air reference gas to the analyser that has constant isotope ratios at dynamic CO<sub>2</sub> mole fractions. The main purpose for this technique is to account for non-linear, CO<sub>2</sub> mole fraction dependent isotope effects (Thermo, 2014).

However, the application of this compulsory referencing technique does not follow the Principle of Identical Treatment (Werner and Brand, 2001), hereafter referred to as PIT, which is regarded as the "golden rule" for isotope referencing in the IRMS community. Therefore, we treat the data output of the Delta Ray as preliminary. We designed our measurement sequences to include two quality control gases (QC-1, QC-2, QC-3) and used QC-1 as working standard to reference the Delta Ray data to the VPDB isotope scale (Table 1), which followed the PIT and improved the reproducibility of QC-2 and QC-3 significantly.

### 2.4 Configuration of analytical setup and measurement sequence

The Delta Ray system configuration comprised of the Delta Ray analyser, two pure CO<sub>2</sub> gases (Kapuni and Marsden), one CO<sub>2</sub>-free air as carrier gas, one air standard for CO<sub>2</sub> mole fractions and two QC gases at a time (Fig. 1). Kapuni and Marsden are configured in the Qtegra as Reference-1 and Reference-2 (Ref-1 and Ref-2), respectively. The Delta Ray analyser includes an inbuilt Nafion system (Nafion, Permapure, USA). However, because this inbuilt Nafion combines the air intake and air outlet in counterflow without water removal, its efficacy is not clear to us, as it potentially mediates water in both directions.



160 Therefore, we used an additional Nafion membrane to dry the incoming air, where the outgoing air was dried using a molesieve  
trap before it was used as drying air in the Nafion membrane. Three-way solenoid valves were used to switch between air  
samples and QC gases. The valves were configured so that air samples were measured in the “normally closed” position, to  
ensure the QC gas cylinders were closed during potential electric failure. Air samples and QC gases were introduced via  
“sample port B”, to fulfil the PIT as much as possible.

165

The Delta Ray has the capability to control up to four external solenoid valves and we used two of these to switch between  
ambient air and the two QC gases. Measurement sequences were defined in Qtegra and executed in continuous cycles (Table  
2). Each measurement sequence begins with the measurement of Ref-1, which is followed by measurement blocks of QC-1,  
air sample and QC-2, before another Ref-1 measurement block marks both the end of the current measurement sequence and  
170 the start of the next measurement sequence. We allowed a flush time of 150 s after each gas change, to ensure complete gas  
replacement in the optical cell. Thereafter, Ref-1 was measured for 300 s, while air and QC gases were measured in three  
blocks of 200 s each, leading to a total time of 45 minutes per measurement sequence. This measurement sequence resulted in  
only 10 min of effective air measurement in every 45 minutes. Because the objective of this test was to assess the analyser  
performance, our sequence included a disproportional amount of QC gas measurements. For the data analysis, we calculated  
175 average values of each measurement block, resulting in ~32 data points for air and QC gases per 24 h period.

Considering the gas flow-rate of 80 mL min<sup>-1</sup> through the analyser, as well as the measurement and flush times we defined for  
reference- and QC gases in the measurement sequence, the Delta Ray consumed 19 L of CO<sub>2</sub>-free air and 32 L of each of the  
two QC gases per day. In this configuration, cylinders with 30 L volume filled to 138 bar (2000 PSI) would be exhausted in  
180 215 days for CO<sub>2</sub>-free air and in 129 days for QC gases. This would require two to three cylinder replacements per year (Table  
2). The QC gas consumption would decrease significantly with greater proportion of air measurements. However, Thermo  
recommends a frequency of Ref-1 measurements of 1 per 30 minutes, which means the CO<sub>2</sub>-free air consumption should not  
be decreased further.

## 185 **2.5 Data correction and uncertainty propagation with QC-1**

QC-1 was selected as working standard to convert all mole fraction and isotope ratio measurements to the respective scales  
(Table 1). QC-1 comprised of natural air with similar mole fractions and isotope ratios of CO<sub>2</sub> to the air measured during the  
campaign to fulfil the PIT.

We derived unprocessed values for  $\delta^{13}\text{C-CO}_2$ ,  $\delta^{18}\text{O-CO}_2$  and CO<sub>2</sub> in QC-1 of  $-8.74 \pm 0.06 \text{ ‰}$ ,  $-1.22 \pm 0.07 \text{ ‰}$  and  $400.88 \pm$   
190  $0.19 \text{ ppm}$ , respectively. The comparison to the calibrated values (Table 1) suggests that the long-term averages of the Delta  
Ray measurements in QC-1 are too depleted in both <sup>13</sup>C and <sup>18</sup>O by  $-0.20 \pm 0.13 \text{ ‰}$  and  $-0.60 \pm 0.11 \text{ ‰}$ , respectively, while  
they are too high in CO<sub>2</sub> by  $0.45 \pm 0.28 \text{ ppm}$  (Table 3). The magnitude of this offset is consistent for QC-2 and QC-3, suggesting



a correction for the offset in QC-1 is suitable for all measured parameters in all gases. We correct all Delta Ray measurements according to:

195

$$X_{s(n)} = X_{DR-s(n)} - (X_{DR-QC1(n)} - X_{scale-QC1}) \quad (1)$$

where  $X_{s(n)}$  is the calibrated sample average as measured in sequence  $n$  on the respective scale,  $X_{DR-s(n)}$  and  $X_{DR-QC1(n)}$  are the measurement averages for the sample and QC-1 within measurements sequence  $n$ , while  $X_{scale-QC1}$  refers to the calibrated value for QC-1 (Table 1).

200

Likewise, we calculated the uncertainty of  $X_{s(n)}$  as

205

$$U_{s(n)} = \sqrt{U_{DR-s(n)}^2 + U_{DR-QC1(n)}^2 + U_{scale-QC1}^2} \quad (2)$$

where  $U_{s(n)}$  is the fully propagated uncertainty of each sample in measurement sequence  $n$ , while  $U_{DR-s(n)}$  and  $U_{DR-QC1(n)}$  are the standard deviations of the Delta Ray measurements for sample and QC-1 in measurement sequence  $n$ , respectively (Section 2.4).  $U_{scale-QC1}$  refers to the uncertainty of the target value assignment of QC-1 (Table 1). This correction and uncertainty propagation is applied to all  $\delta^{13}\text{C-CO}_2$ ,  $\delta^{18}\text{O-CO}_2$  and  $\text{CO}_2$  measurements in air, QC-2 and QC-3.

210

### 3. Assessing instrument sensitivity to variable qualities of $\text{CO}_2$ -free air as carrier gas

#### 3.1 Quality requirements for $\text{CO}_2$ -free air as carrier gas

Optical analysers for measurements of air samples, such as the Delta Ray, are sensitive to changes in the composition of the air matrix, i.e. the mole fractions of  $\text{N}_2$ ,  $\text{O}_2$  and Ar (Werle et al., 1993; Chen et al., 2010; Thermo, 2014), referred to as the pressure-broadening effect. To prevent the pressure-broadening effect, it is of paramount importance that the air matrix in air samples and reference gases is identical, following the PIT. For measurements of natural air samples with the Delta Ray, the  $\text{CO}_2$ -free air used as carrier gas must therefore comprise of a natural, ultra-pure air matrix ( $\text{N}_2 = 78\%$ ,  $\text{O}_2 = 21\%$ ,  $\text{Ar} = 1\%$ ) and have a  $\text{CO}_2$ -blank of  $<0.5$  ppm (Thermo, 2014).

The calibration strategy of the Delta Ray setup as recommended by Thermo is largely dependent on the quality of the  $\text{CO}_2$ -free air, where  $\text{CO}_2$ -free air of sub-optimal quality may limit the achievable accuracy of the system. Because of that, Delta Ray users need to manage their long-term  $\text{CO}_2$ -free air requirements in addition to their reference gas usage. For example, research applications such as long-term atmospheric monitoring with measurement focus on very small signals also require the lowest

220



possible variability in both air matrixes and CO<sub>2</sub> blanks between consecutive CO<sub>2</sub>-free air cylinders. The setup we built for  
225 this study uses Ref-1 as “mediator” only. The final referencing of air measurements is based on QC-1, which fulfils the PIT  
and therefore mitigates potential variability due to variation in the quality of consecutive CO<sub>2</sub>-free air supply.

### 3.2 CO<sub>2</sub>-free air mixed from pure N<sub>2</sub> and O<sub>2</sub>

Commercial CO<sub>2</sub>-free air can be manufactured by mixing main air components of high purity, such as the “Ultra-zero grade  
230 air” from BOC (BOC, Linde Group, Wellington, New Zealand) with CO<sub>2</sub> ≤ 1 ppm, O<sub>2</sub> = 21 ± 1 %, Ar = 0 %, in N<sub>2</sub> balance.  
Ultra-zero grade air is the highest quality zero air product that is readily available in New Zealand, however, its certified values  
neither satisfy the quality criteria for the remaining CO<sub>2</sub> level, nor for the composition of the matrix air. This highlights  
potential logistical limitations to source suitable CO<sub>2</sub>-free air from local gas providers. We attempt to quantify the  
consequences that can be expected when the CO<sub>2</sub>-free air is not meeting requirements. Because instruments in our laboratory  
235 are not calibrated for sub-ppm measurements of CO<sub>2</sub> mole fractions, we introduce the CO<sub>2</sub>-free gases into the Delta Ray and  
measure the transmission in the absorption spectra to get a quantitative estimate of the CO<sub>2</sub> blank (Fig. 2). With a certified  
CO<sub>2</sub> blank of ≤ 1 ppm, the Ultra-zero grade air from BOC resulted in a transmission of 0.7 % on the main peak of the main  
isotopologue (indicated as 626 for <sup>16</sup>O<sup>12</sup>C<sup>16</sup>O). Passing the Ultra-zero grade air through a chemical CO<sub>2</sub> scrubber (Carbosorb,  
Elemental Microanalysis, Devon, UK) reduced the transmission to 0.2 %. By comparing the two transmission values, we think  
240 that it is likely that the chemical scrubbing reduced the CO<sub>2</sub> blank to ≤ 0.5 ppm and thus meets the manufacturer’s CO<sub>2</sub>-blank  
requirements. Further CO<sub>2</sub>-removal from commercial carrier gases may be required to achieve acceptable CO<sub>2</sub> levels.

### 3.3 CO<sub>2</sub>-free air from purified natural air

CO<sub>2</sub>-free air can also be prepared by removing CO<sub>2</sub> from natural air, which minimises the potential to alter the composition of  
245 the air matrix. For the 2015 campaign, we sourced “ultrapure” air from Scott Marrin (now Praxair, Linde Group, Pennsylvania,  
USA), which is made from purified natural air (Scott-Marrin, Lori Thomas, pers. comm, via email on 16 August 2014). In the  
2018 campaign, we prepared CO<sub>2</sub>-free air in NIWA’s atmospheric laboratory. Therefore, we use an oil-free compressor  
(Sweetair, SA-6E, RIX, California, USA) with a 13X molesieve trap (8-12 mesh Sigma-Aldrich) on the compressor inlet in  
combination with a chemical CO<sub>2</sub> scrubber (Carbosorb, Elemental Microanalysis, Devon, UK) on the compressor outlet, and  
250 filled a 30 L cylinder to 50 bar.

The CO<sub>2</sub>-free air produced at NIWA showed a transmission of 0.2 % (Fig. 2). Based on the experiments with the Ultra-zero  
grade air from BOC, we estimate the CO<sub>2</sub>-blank in the CO<sub>2</sub>-free air produced at NIWA to be ≤ 0.5 ppm as well. Because the  
added Carbosorb trap in the experiments with the Ultra-zero grade air from BOC produces CO<sub>2</sub> blanks that are  
indistinguishable from the CO<sub>2</sub> blank in the CO<sub>2</sub>-free air made at NIWA, we conclude that adding the Carbosorb trap not only





255 minimises the CO<sub>2</sub> blank as much as possible but it also homogenises the CO<sub>2</sub> blanks between different CO<sub>2</sub>-free air cylinders,  
which would minimise long-term variability.

Measurements of the O<sub>2</sub>/N<sub>2</sub> ratio in the CO<sub>2</sub>-free air prepared at NIWA confirmed the natural composition of the air matrix  
was preserved during the purification step. Because of that, we assume that natural Ar/N<sub>2</sub> ratios were preserved as well and  
that atmospheric measurements referenced with purified natural air as CO<sub>2</sub>-free air do not create an accuracy offset due to  
260 pressure broadening. In comparison to the Ultra-zero grade air from BOC with an uncertainty of the O<sub>2</sub> mole fraction of ± 1  
%, CO<sub>2</sub>-free air produced with this technique also guarantees a minimal variability in the air matrix between different CO<sub>2</sub>-  
free air cylinders and hence minimal accuracy offsets in long-term measurement series.

### 3.4 Accuracy offsets due to pressure broadening effects in CO<sub>2</sub>-free air

265 To assess the effect of the different CO<sub>2</sub>-free carrier gases on the isotope measurements, we measured the two cylinders, QC-  
4 and QC-5 (Table 1) on the Delta Ray setup, using Ref-1 and different carrier gases: i) CO<sub>2</sub>-free air prepared at NIWA, ii)  
Ultra-zero grade air from BOC, iii) Ultra-zero grade air from BOC with a Carbosorb trap to reduce the CO<sub>2</sub>-blank. We found  
systematic variation in the measured values. While the measurements with the CO<sub>2</sub>-free air prepared at NIWA produced  
accurate isotope values in QC-4 and QC-5 within 0.2 ‰, measurements made with the Ultra-zero grade air from BOC resulted  
270 in offsets in the range of +1.14 ± 0.11 ‰ for δ<sup>13</sup>C-CO<sub>2</sub> and of +0.15 ± 0.04 ‰ for δ<sup>18</sup>O-CO<sub>2</sub>. Reducing the CO<sub>2</sub> blank in the  
Ultra-zero grade air from BOC resulted in slightly larger offsets of +1.24 ± 0.13 ‰ for δ<sup>13</sup>C-CO<sub>2</sub> and in comparable offsets of  
+0.17 ± 0.03 ‰ for δ<sup>18</sup>O-CO<sub>2</sub>. This suggested that the air matrix effect was dominating the offset and that the Ultra-zero grade  
air from BOC was not a suitable CO<sub>2</sub>-free air for the Delta Ray system. Therefore, we operated the Delta Ray with purified  
natural air as carrier gas.

275

## 4. Assessing instrument performance using QC gas measurements in the laboratory

### 4.1 Allan deviation

We determined the Allan deviation of an earlier version of the Delta Ray analyser during the 2015 campaign using QC-1 and  
find values of 0.03 ‰ for both δ<sup>13</sup>C-CO<sub>2</sub> and δ<sup>18</sup>O-CO<sub>2</sub> and <0.01 ppm for CO<sub>2</sub> for integration times of 200 to 300 s (Fig. 3).  
280 These values are comparable to the findings of Braden-Behrens et al., (2017). We use our Allan Deviation results in the design  
of our measurement sequence and schedule blocks between 200 and 300 s for air and QC gases (section 2.4).



#### 4.2 Instrument stability during six hours of QC gas measurements

To test the instrument stability of the Delta Ray in the laboratory prior to deployment at BHD, we measured sequences of QC-1 and QC-2 over 6 h. After 5 h, we observed a sudden 0.4 ‰ shift in both  $\delta^{13}\text{C-CO}_2$  and  $\delta^{18}\text{O-CO}_2$  traces that occurred simultaneously for both gases, while the mole fraction measurements of both gases remained unaffected (Fig. 4). We have no explanation for the sudden shifts at this point but can think of two potential causes for this artefact: i) The Delta Ray experiments were performed in a laboratory of which the temperature was not tightly controlled. Because the laboratory had no external walls or windows, temperature fluctuations were likely below  $0.2^\circ\text{C min}^{-1}$ , which Thermo specifies as acceptable temperature gradients. While we cannot rule out that a greater temperature change occurred, we think it is unlikely that the temperature in the laboratory suddenly changed dramatically. The experiment was made during the period of core working hours, when both the traffic in and out of the laboratory as well as the magnitude of traffic-induced temperature changes are at their maximum. If the laboratory temperature was not suitable for the Delta Ray, we would expect similar shifts during the first 5 h of this experiment, which we did not observe. ii) We speculate that instabilities during the referencing step may have caused that artefact, which would create a simultaneous shift in both QC gases of identical magnitude. We think that this is the most likely explanation, however, we have no means to support this hypothesis. Interestingly, we notice a significant variability in the  $\text{CO}_2$  mole fraction measurements in Figure 7 of Braden-Behrens et al., (2017) during measurements of their “target gas”, which is not reflected in their isotope traces. Furthermore, Figure 7 in Braden-Behrens et al., (2017) shows the same pattern of sudden, synchronous changes in the  $\delta^{13}\text{C-CO}_2$  and  $\delta^{18}\text{O-CO}_2$  measurements of the “target gas” that we observe and describe here. To monitor such artefacts in the following experiments and to be able to correct for such effects, we measured two independent QC gases in every measurement sequence and to apply a calibration scheme that is not entirely based on Ref-1. This enables unambiguous identification whether instability originates from the Delta Ray instrument or the reference gases and it provides the means to remove affected data, or to correct for such effects.

### 5. Instrument deployment at BHD, site description and typical air advection pattern observed during instrument deployment

#### 5.1 The BHD site

The Delta Ray was deployed at BHD, located on the edge of an 85 m southward-facing cliff, overlooking the Southern Ocean ( $41.4083^\circ\text{S}$ ,  $174.8710^\circ\text{E}$ ). BHD lies within a regional park at the southern tip of the greater Wellington region with a population of 520,000. Atmospheric dynamics at BHD are highly variable and complex but show a distinct pattern that is described in detail by Brailsford et al., (2012) and Steinkamp et al., (2017). The topography of New Zealand’s North and South Islands deflect the flow path of advected air masses so that the resulting wind direction at BHD ranges between either north-west to north, or south-west to south-east most of the time (Fig. 11).



When the air is advected from between north-west to north, the air has most likely passed over New Zealand's North Island and potentially includes a significant terrestrial signal. In some cases, air arrives at BHD from true north but has been deflected from further west to south-west where it has passed over the Tasman Sea and does therefore not carry a clear terrestrial signal at all. Furthermore, it may have passed over the northern parts and the West Coast of New Zealand's South Island, in which case it potentially includes a terrestrial signal. Similarly, air advected from south-west to south has potentially passed over the East Coast of New Zealand's South Island, a region marked by major cities and agricultural activity. In summary, air masses advected from either north or south may include a terrestrial signal but may also represent oceanic air. Only air advected from between south to south-east has originated from the Southern Ocean and has not been in contact with land masses for many days. These air masses are amongst the cleanest on the planet and are representative of baseline air. During baseline conditions, the variability of CO<sub>2</sub> mole fractions can be less than 0.1 ppm over several hours and even days (Brailsford et al., 2012; Stephens et al., 2013; Steinkamp et al., 2017). In contrast, northerly air masses that contain a terrestrial CO<sub>2</sub> signal are likely to include anthropogenic CO<sub>2</sub> emissions from urban areas in the greater Wellington region as well. During periods of low wind speeds, the measured CO<sub>2</sub> signal can be dominated by local biogeochemical CO<sub>2</sub> fluxes, where the short-term variability in CO<sub>2</sub> mole fractions can exceed 10 ppm (Stephens et al., 2013; Steinkamp et al., 2017). However, the short-term variability in CO<sub>2</sub> isotope ratios has not yet been quantified during such conditions at BHD.

Flask samples are routinely taken during baseline events and include the analysis of CO<sub>2</sub> isotope ratios at NIWA's atmospheric laboratory in Wellington (Ferretti et al., 2000), as well as for intercomparison programmes with the Scripps Institute of Oceanography and the Institute for Alpine and Arctic Research (Moss et al., 2018). The  $\delta^{13}\text{C}$ -CO<sub>2</sub> time series from BHD shows a variability that is typically within 0.2 ‰ per year and a long-term trend of ~0.3 ‰ per decade towards <sup>13</sup>C depletion, largely a result from continuously added CO<sub>2</sub> from fossil fuel combustion, referred to as the Suess-effect (Keeling et al., 2017).

The BHD observatory is home to many different analytical systems. Continuous measurements of CO<sub>2</sub> mole fractions have been performed at BHD since 1972. A Siemens Ultramat 3 analyser was used from 1985-2016 (Brailsford et al., 2012), while a Picarro G2301 analyser was installed in 2011 (Steinkamp et al., 2017). A Radon analyser was installed in 2015 by the Australian Nuclear Science and Technology Organisation (ANSTO), providing half-hourly average data that indicate the degree to which the measured air mass has been in contact with land masses before reaching BHD (Williams et al., 2011; Chambers et al., 2016). The tower at BHD is equipped with a range of meteorological sensors at 12 m above ground level (Fig. 5). Wind data are measured by 2-D ultrasonic anemometer (Wind Observer II, Gill Instruments, UK) which was installed in May 2013. The raw wind components are measured at 2 Hz and converted to a 3 s average. The 3 s vector components are averaged to 10 minute and hourly wind statistics and stored with other meteorological variables in the station data logger (CR1000, Campbell Scientific Inc, USA). Wind characteristics of the site are described by Stephens et al., (2013). The temperature in the laboratory where the Delta Ray was operated was controlled to  $19.5 \pm 1.5^\circ\text{C}$ , while larger temperature changes may occur during weekly maintenance visits.



## 5.2 Wind direction, wind speed and Radon variability during Delta Ray deployment at BHD

Because the variability of CO<sub>2</sub> mole fractions measured at BHD is strongly controlled by atmospheric advection (Brailsford et al., 2012; Stephens et al., 2013; Steinkamp et al., 2017), we expected that this also applies to the isotopes of CO<sub>2</sub>. Therefore, we will briefly describe characteristics of selected advection patterns that were observed during the Delta Ray deployment at BHD. We support the interpretation of our meteorological observations from BHD with back trajectories from HYSPLIT, an atmospheric transport and dispersion model (Stein et al., 2015; Rolph et al., 2017). Figure 11 shows 30 min averages of Radon data, and hourly averages of both wind speed and wind direction from BHD. Wind direction data are clustered into eight sectors of 45°, i.e. with the centres of clusters north and south being 360/0° and 180°, respectively.

We observed three significant southerly events resulting in baseline/or near baseline CO<sub>2</sub> values on 27 May, 5 June, and 15 June of 2015 (S1, S2 and S3 in Figure 11). These three southerlies are marked by some of the lowest Radon levels in the record, suggesting the measured air had no significant contact with land masses during the days before advection to BHD. While S2 fulfils the strict requirements for a baseline-air event (Brailsford et al., 2012; Steinkamp et al., 2017) between 08:30 and 18:30 on 5 June 2015, both S1 and S3 are not classified as baseline-air events. The accuracy of this classification is corroborated by HYSPLIT back-trajectories for S1 and S3, showing that the air has travelled over New Zealand's South Island before it was measured at BHD, suggesting that air from both S1 and S3 may contain a terrestrial component. In contrast, back trajectories show that air masses measured during S2 have been advected from the Southern Ocean, without direct contact to New Zealand's South Island (Fig. 13).

Furthermore, we observe two long-lasting northerly events from 29 May to 1 June 2015, and from 8 to 11 June 2015 (N1 and N2 in Figure 11). While the average hourly wind speed of N1 with ~10 m s<sup>-1</sup> seems typical for our study period, average wind speeds persistently exceeded ~20 m s<sup>-1</sup> during N2. The very low Radon levels during N2 are comparable with those from S1-S3, indicating the terrestrial impact on the measured CO<sub>2</sub> during N2 was small. Back trajectories for the N2 event show that the air was indeed advected from the Ocean, with very limited contact to land masses before reaching BHD (Fig. 12, F).

We find that the deployment at BHD provides an analytically challenging environment for the Delta Ray analyser, enabling the assessment of its capability to resolve very small to moderate changes in CO<sub>2</sub> mole fractions and isotope ratios. Particularly the three southerlies (S1-S3) with very similar properties provide an opportunity to assess the performance of the Delta Ray system under field conditions at a baseline observatory.



## 375 6. Assessing instrument performance during deployment at BHD

### 6.1 Outlier detection in BHD time series using QC gases

Figure 6 shows all measurements of QC gases during the deployment at BHD as 10-minute averages ( $n=791$ ). All values in this figure are shown as provided by the Delta Ray, i.e. as measured against Ref-1, without further data processing. On 11 June 2015, the QC-2 was nearing a very low pressure and was replaced with QC-3.

380 The  $\delta^{13}\text{C-CO}_2$  and  $\delta^{18}\text{O-CO}_2$  time series from the QC gases vary around their long-term average and do not show a long-term drift (Fig. 6). However, periods of strong variability appear on 21 May, on 25 May and from 10 to 11 June of 2015 that impact on all isotope measurements within the respective 45 min measurement cycle. We did not find a reason for the increased variability. We think that we can rule out that sudden temperature changes have caused the sudden variability, because the most abrupt temperature changes this time of year occur when the door is open during maintenance visits. However,  
385 maintenance visits didn't coincide with the periods of increased variability in the record.

We find that  $\delta^{13}\text{C-CO}_2$  and  $\delta^{18}\text{O-CO}_2$  are affected in the same order of magnitude and that both isotope traces are affected simultaneously while the  $\text{CO}_2$  mole fraction data are not affected at all. This pattern is identical to the sudden shift that we observed in earlier laboratory tests (Section 4.2) and is similar to observations of Braden-Behrens et al., (2017). Measurement sequences are flagged as outlier (yellow symbols in Figure 6), when the  $\delta^{13}\text{C-CO}_2$ , the  $\delta^{18}\text{O-CO}_2$  or the  $\text{CO}_2$  measurements of  
390 QC-1 deviate from their long-term average by more than three standard deviations ( $3\sigma$ ). We reject 20 measurement sequences, affecting around 2.5 % of the measurements, resulting in a total of 791 measurement sequences from the 26 day deployment period. For an unknown reason, the measurements of both isotope ratios in QC-2 show a systematic variability, which does not occur in QC-1 and QC-3 (Fig. 6 and 8), resulting in generally larger standard deviations of the QC-2 data (Table 3).

### 395 6.2 Reproducibility of QC gas measurements during deployment at BHD

Following the removal of outliers, we use the standard deviation ( $1\sigma$ ) of the three QC gas measurements within each measurement cycle as indicator for the reproducibility of the Delta Ray setup. This provides us with 791 values for QC-1, 661 for QC-2 and 130 for QC-3. The histograms in Figure 7 display the distribution of the standard deviation values, showing that the majority of the  $\delta^{13}\text{C-CO}_2$  and  $\delta^{18}\text{O-CO}_2$  values lie within a range that is comparable to the Allan Deviation of 0.03 ‰  
400 (Section 4.1 and Fig. 3). This suggests that the Delta Ray system at BHD is operating close to its maximum performance level for isotope ratio measurements during most of the time. In contrast, the histogram for  $\text{CO}_2$  shows that all standard deviation values from all three QC gases are out of range compared to the Allan Deviation of 0.01 ppm (Section 4.1). Furthermore, the standard deviations of the  $\text{CO}_2$  measurements appear in QC gas specific clusters. The reason for this pattern and the weak performance in  $\text{CO}_2$  measurements remains unclear but is likely associated with effects in the cylinders or pressure regulators  
405 rather than the Delta Ray itself.



### 6.3 Control of linearity and isotope scale compression during deployment at BHD

We compare the average measurement results for the QC gases obtained by the Delta Ray measurements to the target values determined by GC and GC-IRMS analysis in Table 3. QC-1 and QC-2 were designed to cover a large range in CO<sub>2</sub> mole fractions (~97.3 ppm) as well as in  $\delta^{13}\text{C}\text{-CO}_2$  (~4.9 ‰) and  $\delta^{18}\text{O}\text{-CO}_2$  (~5.5 ‰), to assess the capability of the Delta Ray to make accurate measurements over a large range. Table 3 shows good agreement between the Delta Ray measurements and the target values. This suggests that a potential linearity effect is sufficiently controlled via the linearity calibration of the Delta Ray, and that the calibration scheme of the Delta Ray based on Ref-1 and Ref-2 is able to prevent significant scale compression artefacts.

415 However, the QC-1 corrected data seem to overestimate the CO<sub>2</sub> mole fraction in QC-2 by about 0.27 ppm, given a CO<sub>2</sub> difference between QC-1 and QC-2 of 97.3 ppm. In comparison, this difference accounts for only 0.01 ppm for QC-3, which had CO<sub>2</sub> mole fractions that were very similar to that of QC-1. While this difference is within the combined measurement uncertainty for CO<sub>2</sub> mole fractions in both cases, it might be due to inaccurate control of large CO<sub>2</sub> variations. If this overestimation in QC-2 was based on a linear process, it would add an error of +0.0028 ppm ppm<sup>-1</sup> to the mole fraction measurements. Using this value, we estimate that the CO<sub>2</sub> mole fractions in the air measurements of the deployment at BHD would need to exceed or fall below the target value of QC-1 ( $400.43 \pm 0.09$  ppm) by >18 ppm to produce an offset that exceeds the compatibility goal formulated by the WMO, which did not occur during the deployment at BHD. Note that the Delta Ray has the capability for a two-point mole fraction calibration, which we have not utilised during this assessment. It is thus likely that the control of this effect can be improved by a second “concentration standard” (Thermo, 2014).

### 6.4 CO<sub>2</sub> mole fraction measurements in QC gases

The CO<sub>2</sub> mole fraction data from the QC gas cylinders show synchronous variations of similar magnitude (Fig. 6). Interestingly, this feature is similar to observations made by Braden-Behrens et al., (2017), who also found a similar variability in CO<sub>2</sub> mole fraction measurements in cylinder air. A linear regression analysis between QC-1 and QC-2 suggests that about 84 % of the variability in the mole fraction measurements in both cylinders can be explained by the same process. This finding gives strong support for using QC-1 as the working standard in the post-processing protocol for CO<sub>2</sub> mole fractions. Moreover, this highlights the importance to determine and apply correction factors for every single measurement sequence. It is important to note that the prominent features in the CO<sub>2</sub> mole fraction measurements are not reflected in the isotope traces. This suggests that the internal linearity calibration of the Delta Ray is robust for CO<sub>2</sub> variations of that magnitude (Fig. 6).



## 6.5 Assessment of the instrument performance using QC gas measurements from BHD in performance chart method

440 Given the lack of a second QC gas that was measured over the entire campaign and the low quality of the measurements of QC-2, we use the QC-3 time series to assess the reproducibility of the Delta Ray measurements using the performance chart method (Werner and Brand, 2001) in Figure 9. The performance chart is based on  $\delta^{13}\text{C-CO}_2$ ,  $\delta^{18}\text{O-CO}_2$  and  $\text{CO}_2$  values of QC-3, after full corrections have been applied. Error bars represent the fully propagated uncertainty of the measured averages in each sequence. Next, we determine the standard deviation ( $1\sigma$ ) of all  $\delta^{13}\text{C-CO}_2$ ,  $\delta^{18}\text{O-CO}_2$  and  $\text{CO}_2$  values from all QC-3 measurements as indicator of the instrument performance (Werner and Brand, 2001). We find a reproducibility ( $1\sigma$ ) for  $\delta^{13}\text{C-CO}_2$ ,  $\delta^{18}\text{O-CO}_2$  and  $\text{CO}_2$  of 0.07 ‰, 0.06 ‰ and 0.03 ppm, respectively,  $n = 130$ , which we use as a measure of achievable measurement precision. Because the variability in isotope ratios of the relatively short time series for QC-3 is similar to the time series of QC-1 spanning 26 days (Fig. 6, 7 and 8), we think this is a representative estimate.

450 While the precision estimates for both isotope ratios did not meet the WMO network compatibility goal of 0.01 ‰ for  $\delta^{13}\text{C-CO}_2$  and 0.05 ‰ for  $\delta^{18}\text{O-CO}_2$ , they did meet the expanded compatibility goal of 0.1 ‰ for both parameters. However, our instrument precision for  $\text{CO}_2$  mole fractions of 0.03 ppm met the WMO network compatibility goal of 0.05 ppm (WMO-GAW, 2019).

## 7. Assessing the instrument performance by analysing 26 day time series from deployment at BHD

455 The following sections compare the Delta Ray time series to observations made with well-established measurement systems at BHD. Furthermore, we describe and interpret features in the Delta Ray time series in the context of atmospheric advection, with the objective to highlight the capability of the Delta Ray instrument to resolve the variability of  $\text{CO}_2$  and its isotope ratios at BHD under field conditions.

### 7.1 Comparing $\text{CO}_2$ mole fraction measurements from Delta Ray and Siemens Ultramat 3 at BHD

460 We used 5 min average  $\text{CO}_2$  mole fraction measurements from the Siemens Ultramat 3 gas analyser at BHD (Brailsford et al., 2012; Stephens et al., 2013). To compare Siemens and Delta Ray data, we removed periods when the Siemens was in calibration mode from both time series. Next, we sub-sampled the remaining 5 min averages from the Siemens at the time averages of the remaining Delta Ray data by linear interpolation and used the resulting 738 data pairs for comparison.

465 Figure 10 displays the  $\text{CO}_2$  mole fraction data comparison between the Delta Ray and the Siemens analysers. The histogram showed the residuals with a Gaussian distribution, suggesting that the offset was not systematically biased towards either lower



or higher mole fractions. The potential scale effect in our Delta Ray setup of  $0.0028 \text{ ppm ppm}^{-1}$  produced a maximum bias of 0.04 ppm on the 29 May 2015 (Section 6.3). Interestingly, the slope of 0.97 in the comparison confirmed a bias in the Delta Ray data towards higher values (Fig. 10). Out of the 738 data pairs used for the comparisons, 155 or 21 % agreed within the  
470 WMO compatibility goal of 0.05 ppm for the Southern Hemisphere, while 287 or 39 % of the data pairs agreed within the WMO compatibility goal of 0.1 ppm for the Northern Hemisphere, respectively (WMO-GAW, 2019). Furthermore, 542 or 73 % of the data pairs agreed within the standard deviation of the mole fraction averages, which amounted up to a few ppm during times of high  $\text{CO}_2$  variability in the measured air (Fig. 10). In these cases, the large standard deviation coincided with large residual values, suggesting that the agreement between both time series could be improved through synchronisation of  
475 the averaging intervals.

This finding is corroborated by the excellent reproducibility of  $\text{CO}_2$  mole fraction measurements of QC-3 in the performance chart of 0.03 ppm (Section 6.5), suggesting the Delta Ray setup is capable of highly reproducible mole fraction measurements that meet the WMO network compatibility goal.

## 480 7.2 $\text{CO}_2$ mole fraction observations of the Delta Ray during deployment at BHD

The  $\text{CO}_2$  mole fractions during the Delta Ray deployment at BHD varied between 392 ppm and 414 ppm, spanning a total range of 22 ppm. The average  $\text{CO}_2$  mole fraction of 397.09 ppm from the baseline event S2 that occurred on 5 June 2015 is shown with a red line in Figure 11, C.

The most prominent pattern of the  $\text{CO}_2$  mole fraction time series is the daily cycle, which is typically characterised by  $\text{CO}_2$   
485 minima between midday and later afternoon when photosynthetic  $\text{CO}_2$  uptake dominates  $\text{CO}_2$  fluxes; and  $\text{CO}_2$  maxima at night-time during boundary layer build-up of  $\text{CO}_2$  from respiration and anthropogenic sources.  $\text{CO}_2$  peaks are typically accompanied by Radon peaks of proportional magnitude (Fig. 11, D), highlighting the interplay of  $\text{CO}_2$  dilution by wind speed versus  $\text{CO}_2$  accumulation in the boundary layer, as control of the  $\text{CO}_2$  peak amplitude (Williams et al., 2011; Chambers et al., 2016).

490 The largest single event of the  $\text{CO}_2$  time series is the  $\text{CO}_2$  build-up to 414 ppm in the night-time boundary layer in the early hours of 29 May 2015, also coinciding with the largest peak in the Radon time series (Fig. 11, C and D). Back trajectories show the air flow leading up to this event (Fig. 12, B). In the 48 h before measurement at BHD, the measured air had passed over the cities of Dunedin, Christchurch, Lower Hutt and Wellington in a southerly, before the wind direction changed to northerly and the same air passed over Wellington and Lower Hutt again before measurement at BHD. The amplitude of the  
495  $\text{CO}_2$  peak was enhanced by the relatively low wind speeds of  $<5 \text{ m s}^{-1}$ , preventing effective vertical mixing. The advection pattern suggests that both urban  $\text{CO}_2$  emissions and ecosystem respiration contributed to the elevated  $\text{CO}_2$  levels.

We observe seven daily  $\text{CO}_2$  cycles with an amplitude between 10-15 ppm occurring after 1 June 2015. These events are typically associated with air advection across New Zealand's North Island (Fig. 12, E) and moderate wind speeds. However,





500 only four of these events coincide with high Radon peaks (Fig. 11, D). The data gap in the Radon time series on 1 June 2015  
is because the instrument is in calibration mode on the first day of every month. Furthermore, nine daily CO<sub>2</sub> cycles with  
amplitudes between 5-10 ppm and three with amplitudes between 1-5 ppm occur in the record, where most of them have a  
corresponding signal in the Radon time series. However, some exceptions occur where days with ~6 ppm (14 June 2015) or  
even ~13 ppm (2 and 3 June 2015) amplitudes of the daily CO<sub>2</sub> cycle don't show a significant counterpart in the Radon time  
505 series.

Both the amplitude and the timing of these twenty daily CO<sub>2</sub> cycles are controlled by wind direction and wind speed. In general,  
the amplitude of the daily CO<sub>2</sub> mole fraction cycle appears in an inverse relationship with wind speed in the measurements of  
terrestrial air, where higher wind speeds coincide with smaller amplitudes and peak widths in the daily CO<sub>2</sub> cycle. For example,  
510 the largest CO<sub>2</sub> peak during 29 May 2015 occurred when wind speeds were below 5 m s<sup>-1</sup>. In contrast, the daily CO<sub>2</sub> cycle was  
strongly dampened to values between 2 and 4 ppm at persistent wind speeds of ~10 m s<sup>-1</sup> between 30 to 31 May 2015 (N1),  
when the air was advected along the west coast of the North Island (Fig. 12, C). We observed CO<sub>2</sub> cycles with an even smaller  
amplitude of ~1 ppm between 9 and 10 June 2015 (N2). Interestingly, CO<sub>2</sub> minima and maxima appear out of phase with the  
expected timing of daily CO<sub>2</sub> cycle during these days. While the recorded wind direction is true north, back-trajectories show  
515 that the air has been deflected and in fact originated from the Tasman Sea, suggesting that the small CO<sub>2</sub> variability could be  
a distant signal (Fig. 12, F).

As expected for air with Oceanic properties, we observe no daily CO<sub>2</sub> cycle during S1-S3. With the onset of a southerly event,  
an ongoing daily cycle diminishes, and CO<sub>2</sub> mole fractions begin to approach baseline values (Fig. 11, C). Because the air  
520 during a southerly event becomes more stable and cleaner with duration of the event, we focus on the final 6 h period within  
each S1, S2 and S3. We found similar CO<sub>2</sub> mole fractions for S1 and S3 of 397.29 ± 0.07 ppm and 397.21 ± 0.05 ppm,  
respectively, while the baseline air event S2 is marked by slightly lower CO<sub>2</sub> mole fractions of 397.09 ± 0.11 ppm. HYSPLIT  
back trajectories show the S2 has not been in contact with land masses prior to the measurements, while air masses measured  
during both S1 and S3 have been in contact with New Zealand's South Island (Fig. 13). The small difference between S2 on  
525 the one hand and both S1 and S3 may thus be a result from an additional component of terrestrial CO<sub>2</sub> during S1 and S3.

### 7.3 δ<sup>13</sup>C-CO<sub>2</sub> observations of the Delta Ray during deployment at BHD

The δ<sup>13</sup>C-CO<sub>2</sub> data from the field deployment at BHD appear with an average value of about -8.5 ‰. The most prominent  
features in the δ<sup>13</sup>C-CO<sub>2</sub> time series are the systematic daily cycles that occur in concert with CO<sub>2</sub> mole fractions (Fig. 11, B).  
530 The δ<sup>13</sup>C-CO<sub>2</sub> maxima in observed daily cycles are marked with C and are numbered in the δ<sup>13</sup>C-CO<sub>2</sub> time series (Fig. 11, B).  
As expected, the amplitude of the daily cycle in δ<sup>13</sup>C-CO<sub>2</sub> is negatively correlated with that of CO<sub>2</sub> mole fractions, where daily



$\delta^{13}\text{C}\text{-CO}_2$  maxima correspond to day-time minima in  $\text{CO}_2$  mole fractions. The  $R^2$  suggests that 81 % of the variability in  $\delta^{13}\text{C}\text{-CO}_2$  could be explained by the variation of  $\text{CO}_2$  (Fig. 14).

535 This pattern is generally consistent with  $\text{CO}_2$  uptake by plants, which preferentially assimilate  $^{13}\text{C}$  depleted  $\text{CO}_2$ , leading to  $^{13}\text{C}$  enriched  $\text{CO}_2$  in the remaining atmosphere (Ciais et al., 1995a; Bowling et al., 2005; Braden-Behrens et al., 2017). In line with Bowling et al., (2005) and Braden-Behrens et al., (2017), we observe a strong  $\delta^{13}\text{C}\text{-CO}_2$  depletion during the build-up of  $\text{CO}_2$  in the night-time boundary layer, which coincides with Radon build-up, highlighting that terrestrial  $\text{CO}_2$  fluxes caused this variability at our coastal observation site. This pattern is expected as the ground-level  $\text{CO}_2$  increase is caused by ecosystem  
540 respiration (around  $-27.5\text{‰}$  in  $\text{C}_3$  plant dominated ecosystems) or anthropogenic sources ( $-26\text{‰}$  to  $-44\text{‰}$ ), both of which are strongly depleted in  $^{13}\text{C}$  compared to atmospheric  $\delta^{13}\text{C}\text{-CO}_2$  (Vardag et al., 2016; Braden-Behrens et al., 2017).

We observe 19  $\delta^{13}\text{C}\text{-CO}_2$  events (C1-C19). Daily cycles in  $\delta^{13}\text{C}\text{-CO}_2$  that are statistically significant but close to the limit of detection are observed at amplitudes of the daily cycle in  $\text{CO}_2$  mole fractions as low as 2 to 3 ppm (e.g. C6, C7, C15, C17).  
545 This is confirmed by the following back of the envelope calculation. Using the linear regression of the correlation between  $\text{CO}_2$  mole fractions and  $\delta^{13}\text{C}\text{-CO}_2$  (Fig. 14), we can calculate a minimum difference in  $\text{CO}_2$  mole fractions that would theoretically result in a significant  $\delta^{13}\text{C}\text{-CO}_2$  difference of at least twice the  $\delta^{13}\text{C}\text{-CO}_2$  measurement uncertainty of  $\pm 0.07\text{‰}$  (Fig. 9).

550 We find that the Delta Ray setup as described and operated at BHD requires a  $\text{CO}_2$  variability of at least  $\sim 2.6$  ppm in order to measure a  $\delta^{13}\text{C}\text{-CO}_2$  signal that exceeds  $0.14\text{‰}$  or twice the analytical uncertainty. Note that this estimation is critically dependent on the isotopic composition of the locally prevailing  $\text{CO}_2$  source and is therefore specific to the deployment site. The majority of observed daily  $\text{CO}_2$  cycles exceeds an amplitude of 2.6 ppm (Section 7.2), resulting in a typical amplitude of daily  $\delta^{13}\text{C}\text{-CO}_2$  cycles between  $0.2$  and  $0.7\text{‰}$ , thereby exceeding the measurement uncertainty by a factor of 3-10, respectively.  
555 Our observations show that the Delta Ray setup is able to resolve most  $\delta^{13}\text{C}\text{-CO}_2$  variations at BHD that are associated with terrestrial  $\text{CO}_2$  fluxes.

This assessment has so far provided critical indicators of instrument performance such as the achievable instrument precision and the limit of the analytical resolution under field deployment conditions. Further to this, we assess the limitations of the  
560 analysis that can be done on the data from the field deployed instrument using Keeling Plot Analysis (KPA). Following the recommendations of Zobitz et al., (2006) for data with small  $\text{CO}_2$  ranges, we use the Model 1 regression (ordinary least squares) and the standard error as uncertainty of the determined intercept in our KPAs. Bowling et al., (2005) point out that this prevents an erroneous bias of strongly  $^{13}\text{C}$  depleted intercept values at the lowest  $\text{CO}_2$  ranges, which seems to produce realistic intercept results from our data (e.g. Fig. 15, B). We selected twelve events in the  $\text{CO}_2$  and  $\delta^{13}\text{C}\text{-CO}_2$  time series (Fig. 11, B and C)



565 ranging from the smallest (2 ppm) to the largest (16 ppm) CO<sub>2</sub> mole fraction variations. Selected events include six CO<sub>2</sub> peaks  
and six CO<sub>2</sub> troughs, resulting from both night-time boundary layer CO<sub>2</sub> build-up and photosynthetic CO<sub>2</sub> uptake, respectively.

The CO<sub>2</sub> amplitude of these events is well correlated with the amplitude in  $\delta^{13}\text{C-CO}_2$  (Fig. 15, A) with a coefficient of  
correlation of 0.97. As expected from the findings of Pataki et al. (2003), Bowling et al. (2005) and Zobitz et al., (2006), the  
570 uncertainty of our intercepts increases when the range of CO<sub>2</sub> and  $\delta^{13}\text{C-CO}_2$  is small (Fig. 15, C and D). However, it is  
noteworthy that the data of Pataki et al. (2003) require a minimum CO<sub>2</sub> range of 75 ppm to achieve intercept uncertainties of  
 $\leq 1\%$ , whereas Bowling et al. (2005) apply a lower threshold of  $\leq 40$  ppm. In comparison, we find intercept uncertainties of  $\pm$   
 $5\%$  at CO<sub>2</sub> ranges of  $\sim 2.5$  ppm and of  $\sim 1\%$  at CO<sub>2</sub> ranges  $\geq 10$  ppm (Fig. 15, C), which Zobitz et al., (2006) reported as an  
acceptable uncertainty level. For further comparison, Pieber et al., (2021) filter their multi-year data to exclude CO<sub>2</sub> variations  
575  $< 3$  ppm and cluster their data for intercept uncertainties of 1, 2, 3 and 4 %, which indicates the performance of their instrument  
is superior to that of the Delta Ray system presented here. Zobitz et al., (2006) model the improvement in the uncertainty of  
the intercepts with improvement of the measurement precision for isotope ratios. Given the superior measurement precision  
of the Delta Ray setup of  $\pm 0.07\%$  (Section 7.2) in comparison to the setup described by Bowling et al., (2005), the uncertainty  
of the intercepts in our KPAs is smaller as expected. While this proves the gain in the interpretability of measured data with  
580 the instrument performance of the Delta Ray, the comparison with Zobitz et al., (2006) and Pieber et al., (2021) shows that  
further improvement of instrument precision would be desirable to further improve the usefulness of observations.

The intercepts of the KPAs range between  $-23$  and  $-33\%$  with an average of  $-30\%$ , which is around  $-3\%$  more depleted in  
<sup>13</sup>C than the typical intercept values both Pataki et al., (2003) and Bowling et al., (2005) report. However, our intercept values  
are in the range that Vardag et al., (2016) report from an urban site and Braden-Behrens et al., (2017) find at a forest site, as  
585 well as in the range that Pieber et al., (2021) report from observations at a background air location.

Figure 16 A and D show KPA intercepts that are in good agreement with the values from Pataki et al. (2003) and Bowling et  
al., (2005), i.e. the CO<sub>2</sub> build-up in the night-time boundary layer on 26 May 2015 and the photosynthetic CO<sub>2</sub> draw-down on  
2 June 2015 with intercept values of  $-28 \pm 3\%$  and  $-28 \pm 2\%$ , respectively. The intercepts from both events are in the  
expected range for C3 plant dominated ecosystems. Indeed, Figure 12 (A and D) show that the air was advected over the  
590 central South Island on 26 May 2015, while it passed over the central North Island on 2 June 2015. The central parts of both  
islands are predominantly either forest or farmland while urban areas are mostly in the coastal regions, which corroborates the  
KPA result.

These two events are marked by a CO<sub>2</sub> range of 7.5 and 9.2 ppm, respectively (Fig. 12, A and D). In contrast, the photosynthetic  
uptake event on 29 May 2015 is marked by an intercept of  $-29\%$  with a large uncertainty of  $\pm 9\%$  due to the small CO<sub>2</sub> range  
595 of 1.8 ppm (Fig. 12, C). This event directly followed the largest CO<sub>2</sub> peak in our time series. Back trajectories for the day-time  
of 29 May 2015 (not shown) indicate that over the previous 48 h, the measured air was advected from the Tasman sea and has  
only been in contact with land masses in the last hour before measurement. Despite the large uncertainty of the intercept, its



value of  $-29 \pm 9$  ‰ rules out that marine processes have caused the small  $\text{CO}_2$  decrease, because oceanic  $\text{CO}_2$  uptake does not discriminate strongly against  $^{13}\text{C}$ .

600 In contrast, the night-time build-up of  $\text{CO}_2$  in the early hours of the 29 May 2015 is the largest feature of our time series. For that event, our KPA shows an intercept of  $-30 \pm 1$  ‰ (Fig. 16, B), which is slightly more depleted in  $^{13}\text{C}$  than what we would expect for respiration of C3 plant ecosystems (Pataki et al., 2003; Bowling et al., 2005). Back trajectories from that event show that the air measured during this event has passed over the urban areas of Wellington and Lower Hutt (Fig. 12, B), which likely resulted in the impact of additional urban  $\text{CO}_2$  emissions in our measurements. Urban  $\text{CO}_2$  can explain the  $^{13}\text{C}$  depletion of the  
605 intercept, because besides wood, isotopically depleted natural gas is widely used as fuel for residential heating in the Wellington region.

It is important to keep in mind that the nature of observations by Pataki et al., (2003), Bowling et al., (2005), Zobitz et al., (2006) and Braden-Behrens et al., (2017) is fundamentally different from our study as well as from that of Vardag et al., (2016) and Pieber et al., (2021). Due to the remote location of our study site and that of Pieber et al., (2021), observed  $\text{CO}_2$  and  $\delta^{13}\text{C}$ -  
610  $\text{CO}_2$  variations result from a spatio-temporal integration of multiple  $\text{CO}_2$  processes and different ecosystem types along the air flow path. In comparison, the observations of Pataki et al., (2003), Bowling et al., (2005) and Braden-Behrens et al., (2017) were made within one ecosystem, while that of Vardag et al., (2016) were made in an urban environment. Resulting differences between the intercepts derived in these studies are therefore expected.

#### 615 **7.4 $\delta^{18}\text{O}$ - $\text{CO}_2$ observations of the Delta Ray during deployment at BHD**

Over the course of our study period, the  $\delta^{18}\text{O}$ - $\text{CO}_2$  measurements vary around a baseline value of  $+1.1$  ‰ (Fig. 11). This value is in the expected range for a coastal site in the mid latitudes of the Southern Hemisphere, and it is in good agreement with observations from the Commonwealth Scientific and Industrial Research Organisation (CSIRO) at the Cape Grim Observatory (CGO) (Francey and Tans, 1987; Welp et al., 2011). In comparison to  $\delta^{13}\text{C}$ - $\text{CO}_2$ , the  $\delta^{18}\text{O}$ - $\text{CO}_2$  time series does not show a  
620 strong correlation with  $\text{CO}_2$  mole fractions (Fig. 14). The  $\delta^{18}\text{O}$ - $\text{CO}_2$  time series shows 22 distinct events with amplitudes that range between  $0.1$  ‰ and  $1.5$  ‰, labelled O1 – O22 in Figure 11. All events except O8 occur during northerly wind conditions and are most pronounced during low wind speed. All events except O5 and O20 occur during day-time, while  $\delta^{18}\text{O}$ - $\text{CO}_2$  typically declines as Radon levels increase with the build-up of the night-time boundary layer (e.g. O2, O4, O6), when the observed daily  $\delta^{18}\text{O}$ - $\text{CO}_2$  cycle is a signal of the terrestrial biosphere. Atmospheric  $\text{CO}_2$  undergoes oxygen isotope exchange  
625 with  $^{18}\text{O}$ -enriched leaf water (Francey and Tans, 1987; Farquhar et al., 1993; Welp et al., 2011; Cernusak et al., 2016), which is modulated by stomatal conductance that is generally high at day-time and low at night-time (Caird et al., 2007). Most peaks in the  $\delta^{18}\text{O}$ - $\text{CO}_2$  record are therefore a result of photosynthetic activity of the terrestrial biosphere. This explains the lack of a  $\delta^{18}\text{O}$ - $\text{CO}_2$  signal during S1, S2 and S3, when the air was advected over the ocean (Fig. 13) and had limited (S1, S3) or no (S2) contact with the terrestrial biosphere in the recent past.



630 Changes in the  $\delta^{18}\text{O}$ -CO<sub>2</sub> record suggest that the measured CO<sub>2</sub> has been in isotopic exchange with different water bodies of  
different isotopic compositions. Baisden et al., (2016) show the spatial variability of the isotopic composition of precipitation  
in New Zealand. In general,  $\delta^{18}\text{O}$  in precipitation becomes more depleted with i) increasing distance to the equator (latitudinal  
gradient), ii) increasing distance to the precipitation source (Ocean water) and iii) increasing altitude (Dansgaard, 1964;  
Baisden et al., 2016). In a very simplified approach, we can assume that the spatial isotope pattern of the precipitation creates  
635 a corresponding pattern in the isotopic composition of leaf and soil water bodies, which will impact on  $\delta^{18}\text{O}$ -CO<sub>2</sub> during isotope  
exchange accordingly (Farquhar et al., 1993; Cernusak et al., 2016).

An example of this can be observed during 2 to 3 June 2015 and 6 June 2015, when  $\delta^{18}\text{O}$ -CO<sub>2</sub> appears 0.3 ‰ to 0.6 ‰ more  
depleted than average, indicating that this CO<sub>2</sub> has been in isotopic exchange with <sup>18</sup>O depleted leaf and soil water. In fact,  
HYSPLIT back-trajectories show that air masses measured during this period were predominantly advected from inland  
640 regions and higher altitudes (Fig. 12, D), where the  $\delta^{18}\text{O}$  of the precipitation is more depleted than in other regions (Baisden  
et al., 2016).

Interestingly, the night-time events O5 and O20 show an <sup>18</sup>O enrichment of 0.7 to 1.0 ‰, which is accompanied by a  
simultaneous <sup>13</sup>C depletion of ~0.6 ‰ and increased CO<sub>2</sub> mole fractions of 7 to 10 ppm. This combined pattern furthermore  
coincides with peaks in Radon (Fig. 11). Back trajectories from O20 (not shown) reveal that the measured air has been advected  
645 from the West Coast of the South Island, from where it passed over alpine areas as well as over the city of Wellington before  
it was measured at BHD. Schumacher et al., (2011) report <sup>18</sup>O enrichment and <sup>13</sup>C depletion in CO<sub>2</sub> derived from wood  
combustion. It is thus likely that the increased CO<sub>2</sub> originated from a combination of ecosystem respiration and anthropogenic  
combustion processes. In contrast, we observe the opposite  $\delta^{18}\text{O}$ -CO<sub>2</sub> trend during the largest CO<sub>2</sub> peak in our time series (29  
May 2015), which might suggest that the relative contribution of each CO<sub>2</sub> source category is different for O5 and O20 in  
650 comparison to the major CO<sub>2</sub> event on the 29 May 2015.

Our observations show that the Delta Ray is capable of resolving small changes in  $\delta^{18}\text{O}$ -CO<sub>2</sub> and that these measurements  
enable further analysis of anthropogenic and ecosystem processes along the pathways of advected air masses.

## 8. Capabilities and limitations of Delta Ray to resolve small variations of Southern Ocean air events at BHD

### 655 8.1 Variability of CO<sub>2</sub> mole fractions during southerlies

Figure 17 zooms into the measurement data from the three southerly periods S1, S2 and S3. Delta Ray and Siemens data show  
good agreement throughout the events and differences of the event averages (calculated as Delta Ray – Siemens) of –0.03  
ppm, –0.08 ppm and +0.04 ppm CO<sub>2</sub>, for S1, S2 and S3, respectively, which is within the compatibility goal of the WMO for  
S1 and S3, but not for S2. The Delta Ray CO<sub>2</sub> data for S2 include one strongly elevated CO<sub>2</sub> value towards the end of the  
660 event. If this data pair was removed, the disagreement between Delta Ray and Siemens during S2 would increase to –0.11



ppm. Both analysers show S2 with the lowest CO<sub>2</sub> mole fractions, which seems plausible given the potential for added terrestrial CO<sub>2</sub> during both S1 and S3 (Fig. 13). A possible explanation for the variability between measurements is the different measurement schedules both analysers operate on. While the Delta Ray observations follow a measurement schedule containing only 22 % air measurements per cycle (Table 2), the measurement schedule of the Siemens during southerlies  
665 measures air during 50 % of the time and makes thus more than twice as many observations, but not necessarily at the same time as the Delta Ray. The difference in timing may explain some differences between the measurements of both systems. However, we would expect the differences to be minimal during southerly events and especially during steady intervals, as is the case for S2.

## 670 8.2 Accuracy of isotope measurements of Delta Ray, assessed using Southern Ocean events at BHD

Unlike the case for CO<sub>2</sub> mole fractions, we have no means to assess the accuracy of the isotope data from the Delta Ray with independent observations, because the flask sampler at BHD was not operational during the Delta Ray deployment. As a next best solution, we compare the Delta Ray isotope data with IRMS-based data that are available from BHD ( $\delta^{13}\text{C-CO}_2$  only) as well as from the Cape Grim Observatory (CGO) in Tasmania, Australia ( $\delta^{13}\text{C-CO}_2$  and  $\delta^{18}\text{O-CO}_2$ ) from times adjacent to the  
675 Delta Ray time series campaign. We think that this comparison is feasible for two reasons: i) the isotope values for QC-1 were assigned using the same GC-IRMS setup and scale realisation that is also used to make the  $\delta^{13}\text{C-CO}_2$  measurements in the flask samples from BHD (Section 2.2). Therefore, we think that potential calibration offsets between the Delta Ray, NIWA's GC-IRMS and CSIRO's observations at CGO should be minimal. ii) during similar phases of the seasonal cycle, the observable difference between stations in the Southern Hemisphere at comparable latitudes is very small. For example, the seasonal  $\delta^{13}\text{C-}$   
680 CO<sub>2</sub> cycle at CGO is in the order of 0.05 ‰ (Allison and Francey, 2007). The very small  $\delta^{13}\text{C-CO}_2$  variability in Southern Ocean air justifies the comparison of baseline observations from multiple sites (e.g. Ciais et al., (1995a) for  $\delta^{13}\text{C-CO}_2$ , Welp et al., (2011) for  $\delta^{18}\text{O-CO}_2$ , Stephens et al., (2013) for CO<sub>2</sub>).

GC-IRMS measurements are available from flask samples taken at BHD during two southerlies on 28 April 2015 and 23 June 2015, where the latter fulfilled steady interval criteria. Furthermore,  $\delta^{13}\text{C-CO}_2$  and  $\delta^{18}\text{O-CO}_2$  observations were made at CGO  
685 on 13 and 29 May 2015 as well as on 9 and 24 June 2015. We use a linear interpolation between the discrete observations from both BHD and CGO to estimate  $\delta^{13}\text{C-CO}_2$  and  $\delta^{18}\text{O-CO}_2$  values for the periods of S1, S2 and S3. We find good agreement in the interpolated  $\delta^{13}\text{C-CO}_2$  values between samples from BHD and CGO of <0.02 ‰ (green lines in Figure 17), which corroborates our approach to compare measurements made with the Delta Ray to observations made in glass flasks on different times and at a different station in the Southern Ocean. However, the comparison for S1 and S3 is compromised as these events  
690 did not fulfil baseline criteria.

We determine the agreement between the Delta Ray and interpolated IRMS-based measurements (calculated as Delta Ray – IRMS) during S2 as –0.10 ‰ for  $\delta^{13}\text{C-CO}_2$  and –0.20 ‰ for  $\delta^{18}\text{O-CO}_2$  (Fig. 17). For  $\delta^{13}\text{C-CO}_2$ , this difference accounts for



twice the amplitude of the seasonal cycle seen at CGO of  $\sim 0.05$  ‰ (Allison and Francey, 2007), while the range is smaller than the amplitude of the seasonal  $\delta^{18}\text{O}\text{-CO}_2$  cycle observed at CGO during 2015 of  $\sim 0.3$  ‰. In the light of the compatibility  
695 goals of 0.01 ‰ for  $\delta^{13}\text{C}\text{-CO}_2$  and 0.05 ‰ for  $\delta^{18}\text{O}\text{-CO}_2$  (WMO-GAW, 2019), this requires further investigation. In the case of  $\delta^{13}\text{C}\text{-CO}_2$ , this difference accounts for twice the measurement uncertainty, while it exceeds the measurement uncertainty of  $\delta^{18}\text{O}\text{-CO}_2$  by a factor of 4. We can think of a few possible reasons for this difference.

Additional  $\delta^{13}\text{C}\text{-CO}_2$  observations from BHD made in flask samples from 22 July 2015 and 3 September 2015 show  $\delta^{13}\text{C}\text{-CO}_2$   
700 values of  $-8.54 \pm 0.03$  ‰ and  $-8.56 \pm 0.02$  ‰, respectively. While these  $\delta^{13}\text{C}\text{-CO}_2$  values are in the same range as the observations made with the Delta Ray system, they are significantly more depleted in  $^{13}\text{C}$  than all other flask sample observations from BHD and CGO during 2015. It seems thus possible that the  $\delta^{13}\text{C}\text{-CO}_2$  values observed during S1, S2 and S3 are a true atmospheric  $\delta^{13}\text{C}\text{-CO}_2$  signal that is different from the observations at CGO.

Furthermore, this difference may partly be explained by the uncertainty of the target value assignment to the working standard  
705 QC-1, which accounts for 0.07 ‰ for  $\delta^{13}\text{C}\text{-CO}_2$  and 0.04 ‰ for  $\delta^{18}\text{O}\text{-CO}_2$  (Table 1). An offset in the determination of the target value of QC-1 would result in a corresponding shift of the entire Delta Ray data set. While the uncertainty in the value assignment of QC-1 may explain up to 70 % of the difference to the interpolated flask values for  $\delta^{13}\text{C}\text{-CO}_2$ , it can only explain 20 % of that difference in  $\delta^{18}\text{O}\text{-CO}_2$ . Further tests would be required to scrutinise the scale realisation effect but are out of scope for this study.

710 Another aspect that potentially creates an offset in our Delta Ray setup is the systematic difference between the measurements made in air samples at ambient pressure and the measurement of reference gases that are supplied by high-pressure cylinders and delivered to the system at above-ambient pressures. Therefore, measurements of reference and sample gases are made at systematically different pressure regimes. We did not evaluate the impact of different gas supply pressures on the resulting isotope data. However,  $\delta^{13}\text{C}\text{-CO}_2$  measurements using air from glass flasks showed that  $\delta^{13}\text{C}\text{-CO}_2$  was drifting with lowering  
715 pressure in the flask. Even though the Delta Ray should tolerate inlet pressures between 700 and 1200 mbar (Thermo, 2014), our experiments in that pressure window showed isotope effects with a magnitude that could explain the observed difference. Because we set all pressure regulators of the QC gases to identical pressures, a measurement artefact due to pressure differences would affect the measurements of all QC gas cylinder with comparable magnitude. Indeed, our QC gas measurements show similar offsets compared to their assigned target values (Table 3). It is thus possible that an unquantified pressure bias caused  
720 differences between measurements of ambient air and QC gases from cylinders. Further tests with direct comparisons between Delta Ray and IRMS-based methods that explore the effect of different gas delivery pressures are needed to assess factors limiting the accuracy of the Delta Ray.



### 8.3 Limitations of $\delta^{13}\text{C}\text{-CO}_2$ and $\delta^{18}\text{O}\text{-CO}_2$ observations of the Delta Ray during Southern Ocean events at BHD

- 725 The WMO has formulated challenging compatibility goals for the analytical performance of instruments to measure  $\text{CO}_2$ ,  $\delta^{13}\text{C}\text{-CO}_2$  and  $\delta^{18}\text{O}\text{-CO}_2$  in Southern Hemispheric baseline air (WMO-GAW, 2019). However, the specifications of the Delta Ray instrument for isotope ratio measurements exceed the compatibility goals by a factor of 2 to 5. The very small atmospheric variation observable during southerlies at BHD represent a challenging environment to assess the capability and limitations of the instrument.
- 730 Isotope observations during S1, S2 and S3 highlight the limitations of the Delta Ray to resolve small atmospheric variations. We found the average  $\delta^{13}\text{C}\text{-CO}_2$  values of S1 with  $-8.51 \pm 0.02 \text{‰}$  to be by 0.05 ‰ more depleted in  $^{13}\text{C}$  than the values during the steady interval S2 with  $\delta^{13}\text{C}\text{-CO}_2$  of  $-8.46 \pm 0.05 \text{‰}$ . Likewise, S3 with a  $\delta^{13}\text{C}\text{-CO}_2$  of  $-8.48 \pm 0.04 \text{‰}$  was by 0.02 more depleted in  $^{13}\text{C}$  than S2. However, considering the analytical uncertainties of these observations, we are unable to resolve the differences between the events at significant levels. While it seems plausible that S1 and S3 have more negative  $\delta^{13}\text{C}\text{-CO}_2$
- 735 values due to the potential for additional terrestrial  $\text{CO}_2$ , analysing differences of this magnitude does not provide robust results. The same limitations apply to the  $\delta^{18}\text{O}\text{-CO}_2$  results from S1, S2 and S3. An improvement of the achievable measurement precision would be required to resolve the variability or to assess the similarity of isotope ratios during Southern Ocean baseline events.

### 9. Summary and conclusion

- 740 We tested the Delta Ray analyser in the laboratory and at BHD, our observatory for Southern Ocean baseline air. We developed a calibration scheme for the Delta Ray system that is different from that recommended by the manufacturer. Our calibration scheme includes measurements of two quality control gases in every measurement sequence for instrument calibration and assessment, fulfilling the Principle of Identical Treatment (PIT). We achieved a long-term reproducibility of 0.07 ‰ for  $\delta^{13}\text{C}\text{-CO}_2$ , 0.06 ‰ for  $\delta^{18}\text{O}\text{-CO}_2$  and 0.03 ppm for  $\text{CO}_2$  mole fractions. We demonstrated that our changes to the calibration approach
- 745 sufficiently controlled instrument linearity, which was reported as problematic in previous studies (Braden-Behrens et al., 2017; Flores et al., 2017). However, our calibration technique limited the length of time the system was able to measure air within each sequence. A preferred method of operation would be to enable the use of  $\text{CO}_2$  in air standards instead of Ref-1 and Ref-2 at the operator's discretion. Especially when deployed at sites of low  $\text{CO}_2$  mole fraction variability such as BHD, the inbuilt capability for dynamic mixing of Ref-1 and Ref-2 seems unnecessary. The reliance on Ref-1 and Ref-2 adds logistical
- 750 complications due to the strict quality requirements on  $\text{CO}_2$ -free air. We demonstrated the sensitivity of the system to different commercial  $\text{CO}_2$ -free air suppliers and find that commercial or home-made purified air delivered the most accurate results. The deployment period at BHD included a range of atmospheric advection patterns, resulting in daily  $\text{CO}_2$  cycles of variable amplitude, periods with variable degree of terrestrial influence on  $\text{CO}_2$  and reoccurring Southern Ocean events with very little variability of  $\text{CO}_2$  and its isotope ratios (S1, S2 and S3). We think that the deployment at BHD with its very small variation in





755 CO<sub>2</sub> represented a challenging environment to assess the instrument performance of the Delta Ray under field deployed conditions.

Overall, we find the CO<sub>2</sub> mole fraction measurements made with the Delta Ray in good agreement with our well-established system at BHD (Brailsford et al., 2012; Stephens et al., 2013), over mole fraction changes between 2 to 16 ppm (Section 7.1, Fig. 11). We find 39 % and 21 % of the data pairs in agreement with the WMO compatibility goals of 0.1 ppm and 0.05 ppm  
760 for the Northern and Southern Hemisphere, respectively. Existing differences in CO<sub>2</sub> mole fraction measurements likely originate from different data reduction and averaging intervals from both instruments. We expect that synchronising the timing would have further improved the instrument agreement. Our Delta Ray setup relied on a one-point calibration for CO<sub>2</sub> mole fractions only, while a two-point calibration is recommended by the manufacturer for more accurate measurements.

While the instrument performance did not meet the WMO network compatibility goals of 0.01 ‰ for δ<sup>13</sup>C-CO<sub>2</sub> and 0.05 ‰  
765 for δ<sup>18</sup>O-CO<sub>2</sub>, it did meet the WMO expanded compatibility goal of 0.1 ‰ for both δ<sup>13</sup>C-CO<sub>2</sub> and δ<sup>18</sup>O-CO<sub>2</sub>. In line with previous studies, we found the uncertainty of data analysis to be inversely scaled to the amplitude of CO<sub>2</sub> changes (Pataki et al., 2003; Bowling et al., 2005). In comparison to these studies, the superior instrument precision of the Delta Ray enables the analysis of smaller CO<sub>2</sub> signals with smaller amplitude. We demonstrated the capability of Keeling Plot Analysis (KPA) on selected events in the Delta Ray time series to provide intercepts with uncertainty of ~1 ‰ when CO<sub>2</sub> signals exceed 10 ppm.  
770 KPA on smaller CO<sub>2</sub> signals was possible if larger intercept uncertainty was tolerable. However, we found the limit of resolution at ~3 ppm, where the Delta Ray was capable to resolve variations in isotope ratios that were in line with expected δ<sup>13</sup>C-CO<sub>2</sub> and δ<sup>18</sup>O-CO<sub>2</sub> signals based on trajectories of air advection and associated biogeochemical processes. For robust analysis of our data, however, further improvement of the measurement precision to ≤0.01 ‰ would be desirable to meet the WMO network compatibility goal and to distinguish the variability in Southern Ocean baseline air.

775

## 10. Data availability

Date are available upon request.

## 11. Author contributions

780 PS, GWB, RCM and IS conceptualised the study and developed the method, MM supplied the instrument, PS, SMF, BB and JMG analysed the data, SN and PK curated and provided additional data, PS wrote the manuscript with contributions from all authors.



## 12. Competing Interests

785 The authors declare no competing interests.

## 13. Acknowledgements

This work was funded by the National Institute of Water and Atmospheric Research through the Greenhouse Gases, Emissions and Carbon Cycle Science Programme. Further support was received through the CarbonWatch NZ research programme  
790 (C01X1817) and Marsden funded project NIW-1704. We gratefully acknowledge the support from Thermo in supplying us with a Delta Ray demo instrument. The Australian Bureau of Meteorology and CSIRO are thanked for their long-term support of the Cape Grim station and CSIRO GASLAB.

## 14. References

- 795 Allison, C. E. and Francey, R. J.: Verifying Southern Hemisphere trends in atmospheric carbon dioxide stable isotopes, *J. Geophys. Res.-Atmos.*, 112, 27, 10.1029/2006jd007345, 2007.
- Baisden, W. T., Keller, E. D., Van Hale, R., Frew, R. D., and Wassenaar, L. I.: Precipitation isoscapes for New Zealand: enhanced temporal detail using precipitation-weighted daily climatology, *Isot. Environ. Health Stud.*, 52, 343-352, 10.1080/10256016.2016.1153472, 2016.
- 800 Bowling, D. R., Sargent, S. D., Tanner, B. D., and Ehleringer, J. R.: Tunable diode laser absorption spectroscopy for stable isotope studies of ecosystem-atmosphere CO<sub>2</sub> exchange, *Agric. For. Meteorol.*, 118, 1-19, 10.1016/s0168-1923(03)00074-1, 2003.
- Bowling, D. R., Burns, S. P., Conway, T. J., Monson, R. K., and White, J. W. C.: Extensive observations of CO<sub>2</sub> carbon isotope content in and above a high-elevation subalpine forest, *Glob. Biogeochem. Cycle*, 19, 15, 10.1029/2004gb002394, 2005.
- 805 Braden-Behrens, J., Yan, Y., and Knohl, A.: A new instrument for stable isotope measurements of <sup>13</sup>C and <sup>18</sup>O in CO<sub>2</sub> - instrument performance and ecological application of the Delta Ray IRIS analyzer, *Atmos. Meas. Tech.*, 10, 4537-4560, 10.5194/amt-10-4537-2017, 2017.
- Brailsford, G. W., Stephens, B. B., Gomez, A. J., Riedel, K., Mikaloff-Fletcher, S. E., Nichol, S. E., and Manning, M. R.: Long-term continuous atmospheric CO<sub>2</sub> measurements at Baring Head, New Zealand, *Atmos. Meas. Tech.*, 5, 3109-3117,  
810 10.5194/amt-5-3109-2012, 2012.
- Brand, W. A., Rothe, M., Sperlich, P., Strube, M., and Wendeberg, M.: Automated simultaneous measurement of the  $\delta^{13}\text{C}$  and  $\delta^2\text{H}$  values of methane and the  $\delta^{13}\text{C}$  and  $\delta^{18}\text{O}$  values of carbon dioxide in flask air samples using a new multi cryo-trap/gas



- chromatography/isotope ratio mass spectrometry system, *Rapid Commun. Mass Spectrom.*, 30, 1523-1539, 10.1002/rcm.7587, 2016.
- 815 Caird, M. A., Richards, J. H., and Donovan, L. A.: Nighttime stomatal conductance and transpiration in C3 and C4 plants, *Plant Physiol.*, 143, 4-10, 10.1104/pp.106.092940, 2007.
- Cernusak, L. A., Barbour, M. M., Arndt, S. K., Cheesman, A. W., English, N. B., Feild, T. S., Helliker, B. R., Holloway-Phillips, M. M., Holtum, J. A. M., Kahmen, A., Mcinerney, F. A., Munksgaard, N. C., Simonin, K. A., Song, X., Stuart-Williams, H., West, J. B., and Farquhar, G. D.: Stable isotopes in leaf water of terrestrial plants, *Plant Cell Environ.*, 39, 1087-820 1102, 10.1111/pce.12703, 2016.
- Chambers, S. D., Williams, A. G., Conen, F., Griffiths, A. D., Reimann, S., Steinbacher, M., Krummel, P. B., Steele, L. P., Van Der Schoot, M. V., Galbally, I. E., Molloy, S. B., and Barnes, J. E.: Towards a Universal "Baseline" Characterisation of Air Masses for High- and Low-Altitude Observing Stations Using Radon-222, *Aerosol Air Qual. Res.*, 16, 885-899, 10.4209/aaqr.2015.06.0391, 2016.
- 825 Chen, H., Winderlich, J., Gerbig, C., Hofer, A., Rella, C. W., Crosson, E. R., Van Pelt, A. D., Steinbach, J., Kolle, O., Beck, V., Daube, B. C., Gottlieb, E. W., Chow, V. Y., Santoni, G. W., and Wofsy, S. C.: High-accuracy continuous airborne measurements of greenhouse gases (CO<sub>2</sub> and CH<sub>4</sub>) using the cavity ring-down spectroscopy (CRDS) technique, *Atmos. Meas. Tech.*, 3, 375-386, 10.5194/amt-3-375-2010, 2010.
- Ciais, P., Tans, P. P., Trolier, M., White, J. W. C., and Francey, R. J.: A large northern-hemisphere terrestrial CO<sub>2</sub> sink indicated 830 by the <sup>13</sup>C/<sup>12</sup>C ratio of atmospheric CO<sub>2</sub>, *Science*, 269, 1098-1102, 10.1126/science.269.5227.1098, 1995a.
- Ciais, P., Tans, P. P., White, J. W. C., Trolier, M., Francey, R. J., Berry, J. A., Randall, D. R., Sellers, P. J., Collatz, J. G., and Schimel, D. S.: Partitioning of ocean and land uptake of CO<sub>2</sub> as inferred by δ<sup>13</sup>C measurements from the NOAA climate monitoring and diagnostics laboratory global air sampling network, *J. Geophys. Res.-Atmos.*, 100, 5051-5070, 10.1029/94jd02847, 1995b.
- 835 Ciais, P., Denning, A. S., Tans, P. P., Berry, J. A., Randall, D. A., Collatz, G. J., Sellers, P. J., White, J. W. C., Trolier, M., Meijer, H. A. J., Francey, R. J., Monfray, P., and Heimann, M.: A three-dimensional synthesis study of δ<sup>18</sup>O in atmospheric CO<sub>2</sub> I. Surface fluxes, *J. Geophys. Res.-Atmos.*, 102, 5857-5872, 10.1029/96jd02360, 1997.
- Dansgaard, W.: Stable isotopes in precipitation, *Tellus*, 16, 436-468, 1964.
- Farquhar, G. D., Lloyd, J., Taylor, J. A., Flanagan, L. B., Syvertsen, J. P., Hubick, K. T., Wong, S. C., and Ehleringer, J. R.: 840 Vegetation effects on the isotope composition of oxygen in atmospheric CO<sub>2</sub>, *Nature*, 363, 439-443, 10.1038/363439a0, 1993.
- Ferretti, D. F., Lowe, D. C., Martin, R. J., and Brailsford, G. W.: A new gas chromatograph-isotope ratio mass spectrometry technique for high-precision, N<sub>2</sub>O-free analysis of δ<sup>13</sup>C and δ<sup>18</sup>O in atmospheric CO<sub>2</sub> from small air samples, *J. Geophys. Res.-Atmos.*, 105, 6709-6718, 10.1029/1999jd901051, 2000.



- Flores, E., Viallon, J., Moussay, P., Griffith, D. W. T., and Wielgosz, R. I.: Calibration Strategies for FT-IR and Other Isotope  
845 Ratio Infrared Spectrometer Instruments for Accurate  $\delta^{13}\text{C}$  and  $\delta^{18}\text{O}$  Measurements of  $\text{CO}_2$  in Air, *Anal. Chem.*, 89, 3648-  
3655, 10.1021/acs.analchem.6b05063, 2017.
- Francey, R. J. and Tans, P. P.: Latitudinal variation in oxygen-18 of atmospheric  $\text{CO}_2$ , *Nature*, 327, 495-497,  
10.1038/327495a0, 1987.
- Griffis, T. J., Sargent, S. D., Baker, J. M., Lee, X., Tanner, B. D., Greene, J., Swiatek, E., and Billmark, K.: Direct measurement  
850 of biosphere-atmosphere isotopic  $\text{CO}_2$  exchange using the eddy covariance technique, *J. Geophys. Res.-Atmos.*, 113, 20,  
10.1029/2007jd009297, 2008.
- Griffith, D. W. T., Deutscher, N. M., Caldow, C., Kettlewell, G., Riggenbach, M., and Hammer, S.: A Fourier transform  
infrared trace gas and isotope analyser for atmospheric applications, *Atmos. Meas. Tech.*, 5, 2481-2498, 10.5194/amt-5-2481-  
2012, 2012.
- 855 Hammer, S., Griffith, D. W. T., Konrad, G., Vardagl, S., Caldow, C., and Levin, I.: Assessment of a multi-species in situ FTIR  
for precise atmospheric greenhouse gas observations, *Atmos. Meas. Tech.*, 6, 1153-1170, 10.5194/amt-6-1153-2013, 2013.
- Keeling, R. F., Graven, H. D., Welp, L. R., Resplandy, L., Bi, J., Piper, S. C., Sun, Y., Bollenbacher, A., and Meijer, H. A. J.:  
Atmospheric evidence for a global secular increase in carbon isotopic discrimination of land photosynthesis, *Proc. Natl. Acad.  
Sci. U. S. A.*, 114, 10361-10366, 10.1073/pnas.1619240114, 2017.
- 860 Lowe, D. C., Brenninkmeijer, C. A. M., Brailsford, G. W., Lassey, K. R., Gomez, A. J., and Nisbet, E. G.: Concentration and  
 $^{13}\text{C}$  records of atmospheric methane in New Zealand and Antarctica - evidence for changes in methane sources, *J. Geophys.  
Res.-Atmos.*, 99, 16913-16925, 10.1029/94jd00908, 1994.
- Mohn, J., Werner, R. A., Buchmann, B., and Emmenegger, L.: High-precision  $\delta^{13}\text{C}\text{CO}_2$  analysis by FTIR spectroscopy using a  
novel calibration strategy, *J. Mol. Struct.*, 834, 95-101, 10.1016/j.molstruc.2006.09.024, 2007.
- 865 Moss, R., Brailsford, G., Martin, R. J., Nankivell, C., Nichol, S., Sperlich, P., Mikaloff-Fletcher, S. E., Tans, P. P., Englund-  
Michel, S., Keeling, R. F., Werczynski, S., Gorjan, P., and Mandic, M.: A43N-3313: NIWA's  $\delta^{13}\text{C}\text{-CO}_2$  Measurement  
Programme: Twenty Years of Monitoring in New Zealand and Antarctica, including the Performance Assessment of an in-situ  
Analyser at Baring Head, AGU Fall Meeting 2018, Washington, USA, 13th December 2018.
- Pataki, D. E., Ehleringer, J. R., Flanagan, L. B., Yakir, D., Bowling, D. R., Still, C. J., Buchmann, N., Kaplan, J. O., and Berry,  
870 J. A.: The application and interpretation of Keeling plots in terrestrial carbon cycle research, *Glob. Biogeochem. Cycle*, 17,  
15, 10.1029/2001gb001850, 2003.
- Pieber, S. M., Tuzon, B., Henne, S., Karstens, U., Gerbig, C., Koch, F. T., Brunner, D., Steinbacher, M., and Emmenegger,  
L.: Analysis of regional  $\text{CO}_2$  contributions at the high Alpine observatory Jungfraujoch by means of atmospheric transport  
simulations and  $\delta^{13}\text{C}$ , *Atmospheric Chemistry and Physics Discussions*, in review, 10.5194/acp-2021-644, 2021.
- 875 Rizzo, A. L., Jost, H. J., Caracausi, A., Paonita, A., Liotta, M., and Martelli, M.: Real-time measurements of the concentration  
and isotope composition of atmospheric and volcanic  $\text{CO}_2$  at Mount Etna (Italy), *Geophys. Res. Lett.*, 41, 2382-2389,  
10.1002/2014gl059722, 2014.



- Rolph, G., Stein, A., and Stunder, B.: Real-time Environmental Applications and Display sYstem: READY, Environ. Modell. Softw., 95, 210-228, 10.1016/j.envsoft.2017.06.025, 2017.
- 880 Rothe, M., Jordan, A., and Brand, W. A.: Trace gases,  $\delta^{13}\text{C}$  and  $\delta^{18}\text{O}$  of  $\text{CO}_2$ -in-air samples: Storage in glass flasks using PCTFE seals and other effects, 12<sup>th</sup> IAEA/WMO meeting of  $\text{CO}_2$  experts, Toronto, Canada, 2005.
- Schipper, C. I., Moussallam, Y., Curtis, A., Peters, N., Barnie, T., Bani, P., Jost, H. J., Hamilton, D., Aiuppa, A., Tamburello, G., and Giudice, G.: Isotopically ( $\delta^{13}\text{C}$  and  $\delta^{18}\text{O}$ ) heavy volcanic plumes from Central Andean volcanoes: a field study, Bull. Volcanol., 79, 15, 10.1007/s00445-017-1146-4, 2017.
- 885 Schumacher, M., Werner, R. A., Meijer, H. A. J., Jansen, H. G., Brand, W. A., Geilmann, H., and Neubert, R. E. M.: Oxygen isotopic signature of  $\text{CO}_2$  from combustion processes, Atmos. Chem. Phys., 11, 1473-1490, 10.5194/acp-11-1473-2011, 2011.
- Stein, A. F., Draxler, R. R., Rolph, G. D., Stunder, B. J. B., Cohen, M. D., and Ngan, F.: NOAA'S Hysplit atmospheric transport and dispersion modelling system, Bull. Amer. Meteorol. Soc., 96, 2059-2077, 10.1175/bams-d-14-00110.1, 2015.
- Steinkamp, K., Mikaloff-Fletcher, S. E., Brailsford, G., Smale, D., Moore, S., Keller, E. D., Baisden, W. T., Mukai, H., and  
890 Stephens, B. B.: Atmospheric  $\text{CO}_2$  observations and models suggest strong carbon uptake by forests in New Zealand, Atmos. Chem. Phys., 17, 47-76, 10.5194/acp-17-47-2017, 2017.
- Stephens, B. B., Brailsford, G. W., Gomez, A. J., Riedel, K., Mikaloff-Fletcher, S. E., Nichol, S., and Manning, M.: Analysis of a 39-year continuous atmospheric  $\text{CO}_2$  record from Baring Head, New Zealand, Biogeosciences, 10, 2683-2697, 10.5194/bg-10-2683-2013, 2013.
- 895 Steur, P. M., Scheeren, H. A., Nelson, D. D., Mcmanus, J. B., and Meijer, H. A. J.: Simultaneous measurement of  $\delta^{13}\text{C}$ ,  $\delta^{18}\text{O}$  and  $\delta^{17}\text{O}$  of atmospheric  $\text{CO}_2$  - performance assessment of a dual-laser absorption spectrometer, Atmos. Meas. Tech., 14, 4279-4304, 10.5194/amt-14-4279-2021, 2021.
- Sturm, P., Tuzson, B., Henne, S., and Emmenegger, L.: Tracking isotopic signatures of  $\text{CO}_2$  at the high altitude site Jungfraujoch with laser spectroscopy: analytical improvements and representative results, Atmos. Meas. Tech., 6, 1659-1671,  
900 10.5194/amt-6-1659-2013, 2013.
- Thermo: Delta Ray Isotope Ratio Infrared Spectrometer, User Guide, 2014.
- Töchterle, P., Dublyansky, Y., Stöbener, N., Mandic, M., and Spötl, C.: High-resolution isotopic monitoring of cave air  $\text{CO}_2$ , Rapid Commun. Mass Spectrom., 31, 895-900, 10.1002/rcm.7859, 2017.
- Tuzson, B., Henne, S., Brunner, D., Steinbacher, M., Mohn, J., Buchmann, B., and Emmenegger, L.: Continuous isotopic  
905 composition measurements of tropospheric  $\text{CO}_2$  at Jungfraujoch (3580 m a.s.l.), Switzerland: real-time observation of regional pollution events, Atmos. Chem. Phys., 11, 1685-1696, 10.5194/acp-11-1685-2011, 2011.
- Van Geldern, R., Nowak, M. E., Zimmer, M., Szizybalski, A., Myrntinen, A., Barth, J. A. C., and Jost, H. J.: Field-Based Stable Isotope Analysis of Carbon Dioxide by Mid-Infrared Laser Spectroscopy for Carbon Capture and Storage Monitoring, Anal. Chem., 86, 12191-12198, 10.1021/ac5031732, 2014.



- 910 Vardag, S. N., Hammer, S., and Levin, I.: Evaluation of 4 years of continuous  $\delta^{13}\text{C}(\text{CO}_2)$  data using a moving Keeling plot method, *Biogeosciences*, 13, 4237-4251, 10.5194/bg-13-4237-2016, 2016.
- Vardag, S. N., Hammer, S., Sabasch, M., Griffith, D. W. T., and Levin, I.: First continuous measurements of  $\delta^{18}\text{O}-\text{CO}_2$  in air with a Fourier transform infrared spectrometer, *Atmos. Meas. Tech.*, 8, 579-592, 10.5194/amt-8-579-2015, 2015.
- Wehr, R., Munger, J. W., Nelson, D. D., Mcmanus, J. B., Zahniser, M. S., Wofsy, S. C., and Saleska, S. R.: Long-term eddy  
915 covariance measurements of the isotopic composition of the ecosystem-atmosphere exchange of  $\text{CO}_2$  in a temperate forest, *Agric. For. Meteorol.*, 181, 69-84, 10.1016/j.agrformet.2013.07.002, 2013.
- Welp, L. R., Keeling, R. F., Meijer, H. A. J., Bollenbacher, A. F., Piper, S. C., Yoshimura, K., Francey, R. J., Allison, C. E., and Wahlen, M.: Interannual variability in the oxygen isotopes of atmospheric  $\text{CO}_2$  driven by El Nino, *Nature*, 477, 579-582, 10.1038/nature10421, 2011.
- 920 Werle, P., Mucke, R., and Slemr, F.: The limits of signal averaging in atmospheric trace-gas monitoring by Tunable Diode-Laser-Absorption-Spectroscopy (TDLAS), *Applied Physics B-Photophysics and Laser Chemistry*, 57, 131-139, 10.1007/bf00425997, 1993.
- Werner, R. A. and Brand, W. A.: Referencing strategies and techniques in stable isotope ratio analysis, *Rapid Commun. Mass Spectrom.*, 15, 501-519, 10.1002/rcm.258, 2001.
- 925 Werner, R. A., Rothe, M., and Brand, W. A.: Extraction of  $\text{CO}_2$  from air samples for isotopic analysis and limits to ultra high precision  $\delta^{18}\text{O}$  determination in  $\text{CO}_2$  gas, *Rapid Commun. Mass Spectrom.*, 15, 2152-2167, 10.1002/rcm.487, 2001.
- Williams, A. G., Zahorowski, W., Chambers, S., Griffiths, A., Hacker, J. M., Element, A., and Werczynski, S.: The Vertical Distribution of Radon in Clear and Cloudy Daytime Terrestrial Boundary Layers, *J. Atmos. Sci.*, 68, 155-174, 10.1175/2010jas3576.1, 2011.
- 930 WMO-GAW: 20<sup>th</sup> WMO/IAEA Meeting on Carbon Dioxide, Other Greenhouse Gases and Related Measurement Techniques (GGMT-2019), WMO Report No. 255, 2019.
- Zobitz, J. M., Keener, J. P., Schnyder, H., and Bowling, D. R.: Sensitivity analysis and quantification of uncertainty for isotopic mixing relationships in carbon cycle research, *Agric. For. Meteorol.*, 136, 56-75, 10.1016/j.agrformet.2006.01.003, 2006.

935

940



945 **Table 1: Two pure CO<sub>2</sub> gases used as reference gases (Marsden, Kapuni) were calibrated to VPDB realisation of Lowe et al. (1994). QC-1, QC-2 and QC-3 served as air standard and as target gases, respectively, while QC-4 and QC-5 were used during laboratory tests. Mole fractions and isotope ratios are provided with the 1 $\sigma$  uncertainty of their measurement.**

name	function	cylinder	gas matrix	CO <sub>2</sub> [ppm]	u_CO <sub>2</sub> [ppm]	$\delta^{13}\text{C}$ [‰]	u_ $\delta^{13}\text{C}$ [‰]	$\delta^{18}\text{O}$ [‰]	u_ $\delta^{18}\text{O}$ [‰]	gas provider
Kapuni	Ref-1	46	pure CO <sub>2</sub>	100 %		-13.748	0.1	-11.695	0.1	BOC
Marsden	Ref-2	26	pure CO <sub>2</sub>	100 %		-32.768	0.1	-32.518	0.1	Air Liquide
CO <sub>2</sub> -free air	carrier, BHD deployment	CB11048	purified natural air	<1						Scott Marrin
CO <sub>2</sub> -free air	carrier, experiment		purified natural air	<1						NIWA
CO <sub>2</sub> -free air	carrier, experiment		synthetic N <sub>2</sub> /O <sub>2</sub> mixture, no Ar	<1						BOC
QC-1	standard	CB 09725	natural air	400.43	±0.09	-8.54	±0.07	-0.62	±0.04	NIWA
QC-2	target 1	43410	natural air with CO <sub>2</sub> spike	497.71	±0.07	-13.42	±0.02	-6.11	±0.07	NIWA
QC-3	target 2	CB10800	natural air	396.03	±0.06	-8.32	±0.04	+0.31	±0.01	NIWA
QC-4	test gas	6235	natural air	402.78	±0.04	-8.47	±0.01	+0.17	±0.02	NIWA
QC-5	test gas	6260	natural air with CO <sub>2</sub> spike	424.9	±1.5	-9.82	±0.01	-1.35	±0.04	NIWA

950

955

960



965 **Table 2: Timing used for blocks in measurement sequence, resulting gas consumptions, resulting requirements for cylinder replacements per year and relative time each gas was measured.**

gas	time [s]	measure/flush	consumption [L/d]	replacements / a	relative use time [%]	relative measurement time [%]
Ref-1 + carrier	150	flush	19	2	16.7	11.1
Ref-1 + carrier	300	measure				
QC-1	150	flush	32	3	27.8	22.2
QC-1	200	measure				
QC-1	200	measure				
QC-1	200	measure				
air sample	150	flush	32	–	27.8	22.2
air sample	200	measure				
air sample	200	measure				
air sample	200	measure				
QC-2, QC-3	150	flush	32	3	27.8	22.2
QC-2, QC-3	200	measure				
QC-2, QC-3	200	measure				
QC-2, QC-3	200	measure				
Ref-1 + carrier	150	flush	–	next cycles 1 <sup>st</sup> measurement	–	
Ref-1 + carrier	300	measure				

970

975

980





985 **Table 3: Target values (GC and GC-IRMS) and Delta Ray measurements for QC-1, QC-2 and QC-3 as determined during operation at BHD and differences as Delta Ray minus GC-IRMS and values for QC-2 after correction for the offset in QC-1 minus the GC-IRMS target value.**

	QC-1	QC-2	QC-3
<b>system</b>	$\delta^{13}\text{C-CO}_2$ [‰]	$\delta^{13}\text{C-CO}_2$ [‰]	$\delta^{13}\text{C-CO}_2$ [‰]
GC-IRMS	$-8.54 \pm 0.07$	$-13.42 \pm 0.02$	$-8.32 \pm 0.04$
Delta Ray	$-8.74 \pm 0.06$	$-13.60 \pm 0.12$	$-8.54 \pm 0.07$
Delta Ray – GC-IRMS	$-0.20 \pm 0.13$	$-0.18 \pm 0.14$	$-0.22 \pm 0.11$
QC-1-corr – GC-IRMS		+0.02	-0.02

	QC-1	QC-2	QC-3
<b>system</b>	$\delta^{18}\text{O-CO}_2$ [‰]	$\delta^{18}\text{O-CO}_2$ [‰]	$\delta^{18}\text{O-CO}_2$ [‰]
GC-IRMS	$-0.62 \pm 0.04$	$-6.11 \pm 0.07$	$+0.31 \pm 0.01$
Delta Ray	$-1.22 \pm 0.07$	$-6.80 \pm 0.14$	$-0.31 \pm 0.07$
Delta Ray – GC-IRMS	$-0.60 \pm 0.11$	$-0.69 \pm 0.21$	$-0.62 \pm 0.08$
QC-1-corr – GC-IRMS		-0.08	-0.04

  

	QC-1	QC-2	QC-3
<b>system</b>	$\text{CO}_2$ [ppm]	$\text{CO}_2$ [ppm]	$\text{CO}_2$ [ppm]
GC	$400.43 \pm 0.09$	$497.71 \pm 0.07$	$396.03 \pm 0.06$
Delta Ray	$400.88 \pm 0.19$	$498.41 \pm 0.22$	$396.54 \pm 0.12$
Delta Ray – GC	$0.45 \pm 0.28$	$0.71 \pm 0.29$	$0.51 \pm 0.18$
QC-1-corr – GC		0.27	0.01

990

995

1000

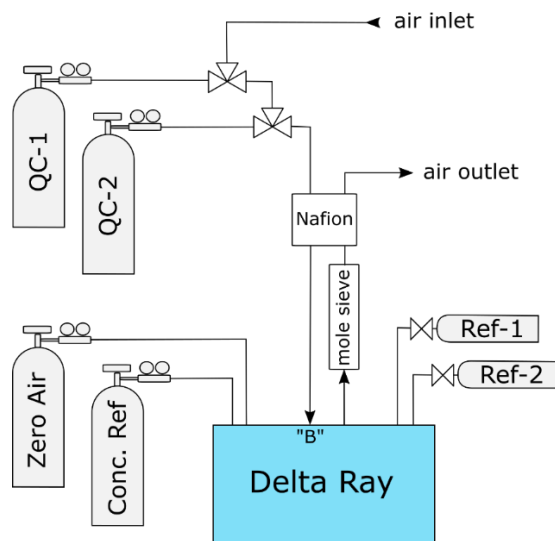
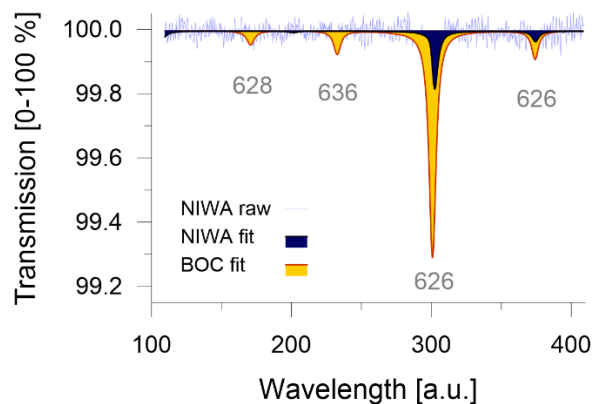

**Figure 1: Delta Ray setup as deployed at BHD.**

1005

1010

1015



**Figure 2:** Size of CO<sub>2</sub> blank in CO<sub>2</sub>-free air, transmission [%] over “artificial units [a.u.]”, provided by Delta Ray. Raw (light blue) and fitted (dark blue) data from CO<sub>2</sub>-free air made at NIWA in comparison with fitted spectra of BOC’s Ultra-zero grade air (orange).

1020

1025

1030

1035

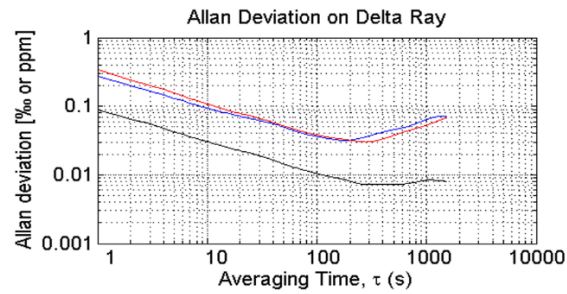

Figure 3: Allan deviation determined in QC-1: blue =  $\delta^{13}\text{C}$ , red =  $\delta^{18}\text{O}$ , black =  $\text{CO}_2$ , determined during the 2015 campaign.

1040

1045

1050

1055

1060

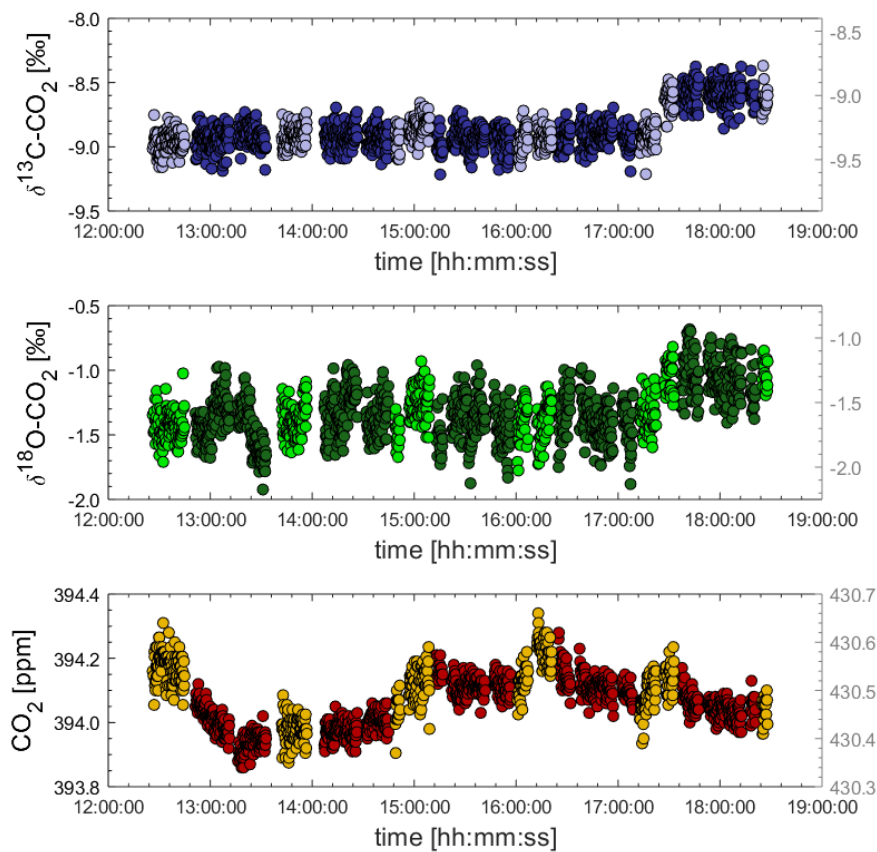

**Figure 4: Sudden and synchronous shift in both  $\delta^{13}\text{C-CO}_2$  (top) and  $\delta^{18}\text{O-CO}_2$  (middle) affecting the measurement of two QC gases during laboratory tests. Shifts in isotope traces are not reflected in  $\text{CO}_2$  mole fractions (bottom). Causes of the isotope shifts are unknown.**

1065

1070

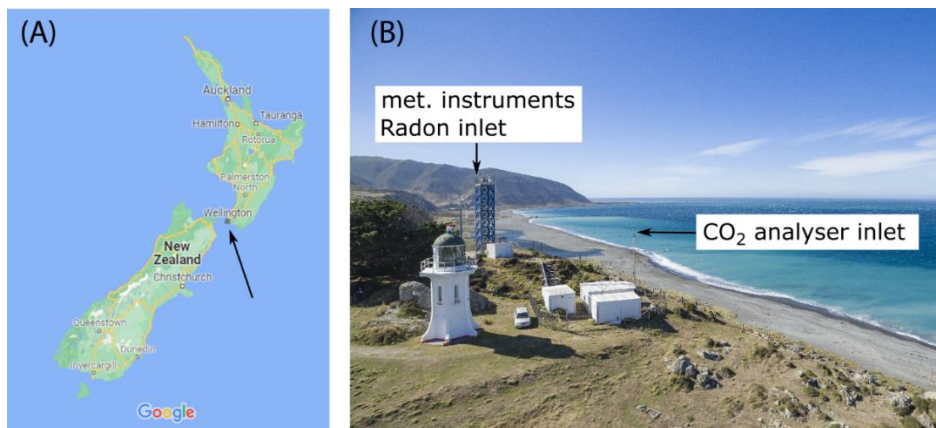

**Figure 5:** Left: Arrow highlights the location of BHD in New Zealand (© Google Maps 2021). Right: Aerial photograph of BHD (provided by Dave Allen, NIWA).

1075

1080

1085

1090

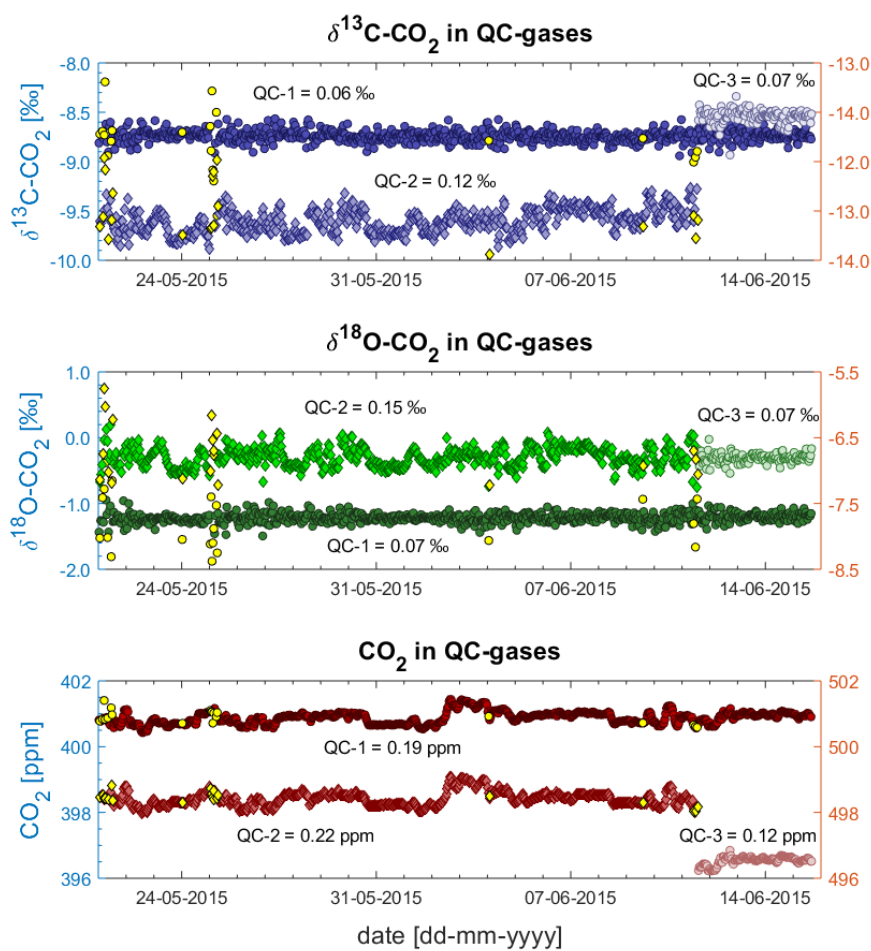

1095

Figure 6: QC gas data as measured against Ref-1 during deployment at BHD,  $\delta^{13}\text{C-CO}_2$  (top),  $\delta^{18}\text{O-CO}_2$  (middle) and  $\text{CO}_2$  mole fractions (bottom). QC-1 and QC-3 on left y-axes, QC-2 on right y-axes.

1100

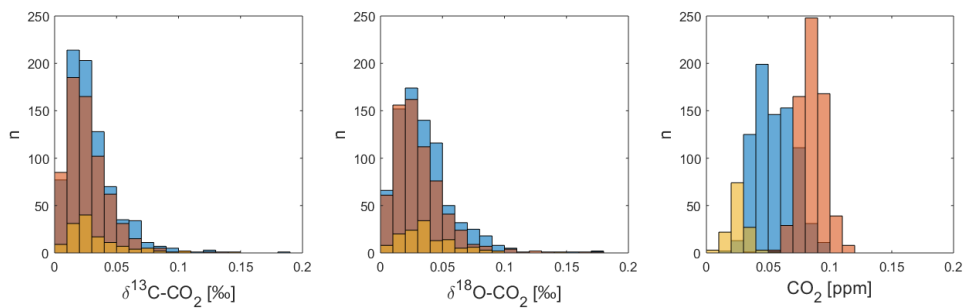

1105

**Figure 7: Internal reproducibility as the standard deviation ( $1\sigma$ ) of the QC gas block averages in each sequence for  $\delta^{13}\text{C-CO}_2$  (left),  $\delta^{18}\text{O-CO}_2$  (middle) and  $\text{CO}_2$  mole fractions (right), outliers excluded. QC-1 in blue, QC-2 in red and QC-3 in yellow.**

1110

1115

1120

1125



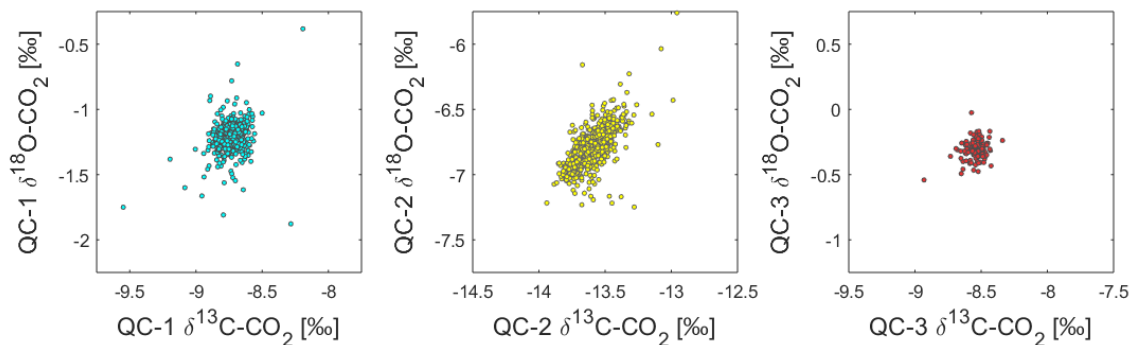

1130

**Figure 8: Correlation of  $\delta^{13}\text{C-CO}_2$  and  $\delta^{18}\text{O-CO}_2$  values in QC-1 (left), QC-2 (middle) and QC-3 (right) before outlier removal and correction for QC-1.**

1135

1140

1145

1150

1155

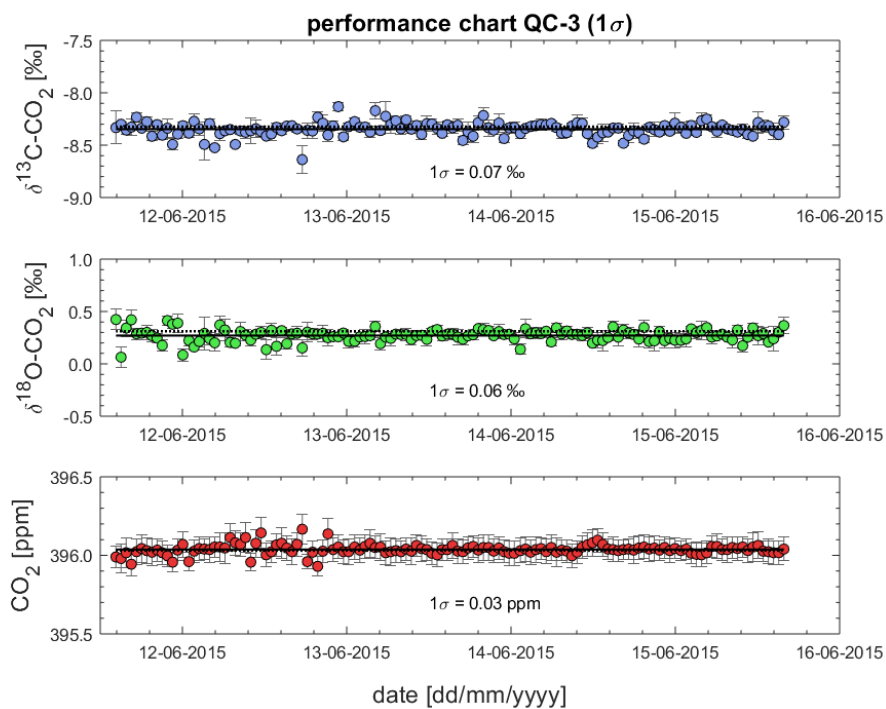
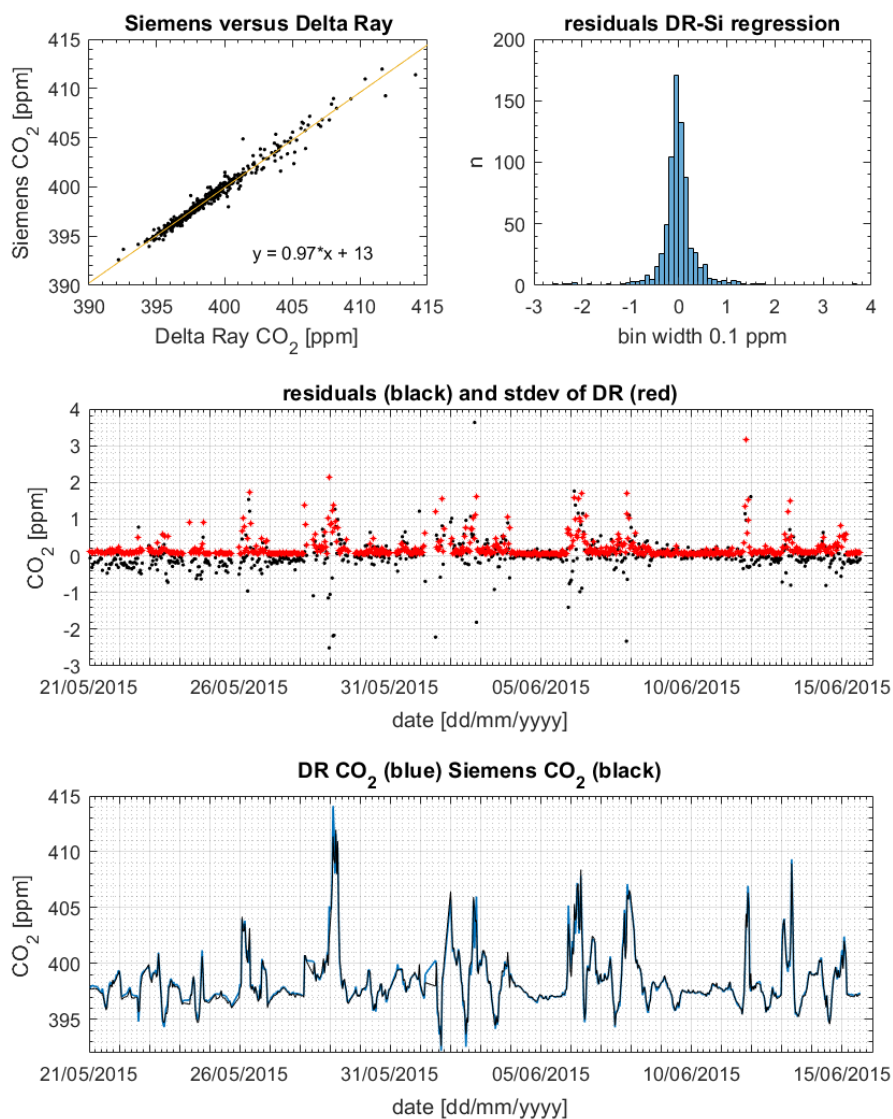

**Figure 9:** Sequence averages for processed  $\delta^{13}\text{C-CO}_2$  (top),  $\delta^{18}\text{O-CO}_2$  (middle) and  $\text{CO}_2$  (bottom) in QC-3. The standard deviation ( $1\sigma$ ) is a measure of the achievable analytical precision.

1160

1165

1170



1175 **Figure 10: Top left: slope and scatter of the regression Siemens (Si) versus Delta Ray (DR). Top right: histogram of residuals (top right). Middle: residuals (black) and 1σ standard deviation of the DR measurements (red). Bottom: CO<sub>2</sub> mole fractions from DR (blue) and Siemens (black).**

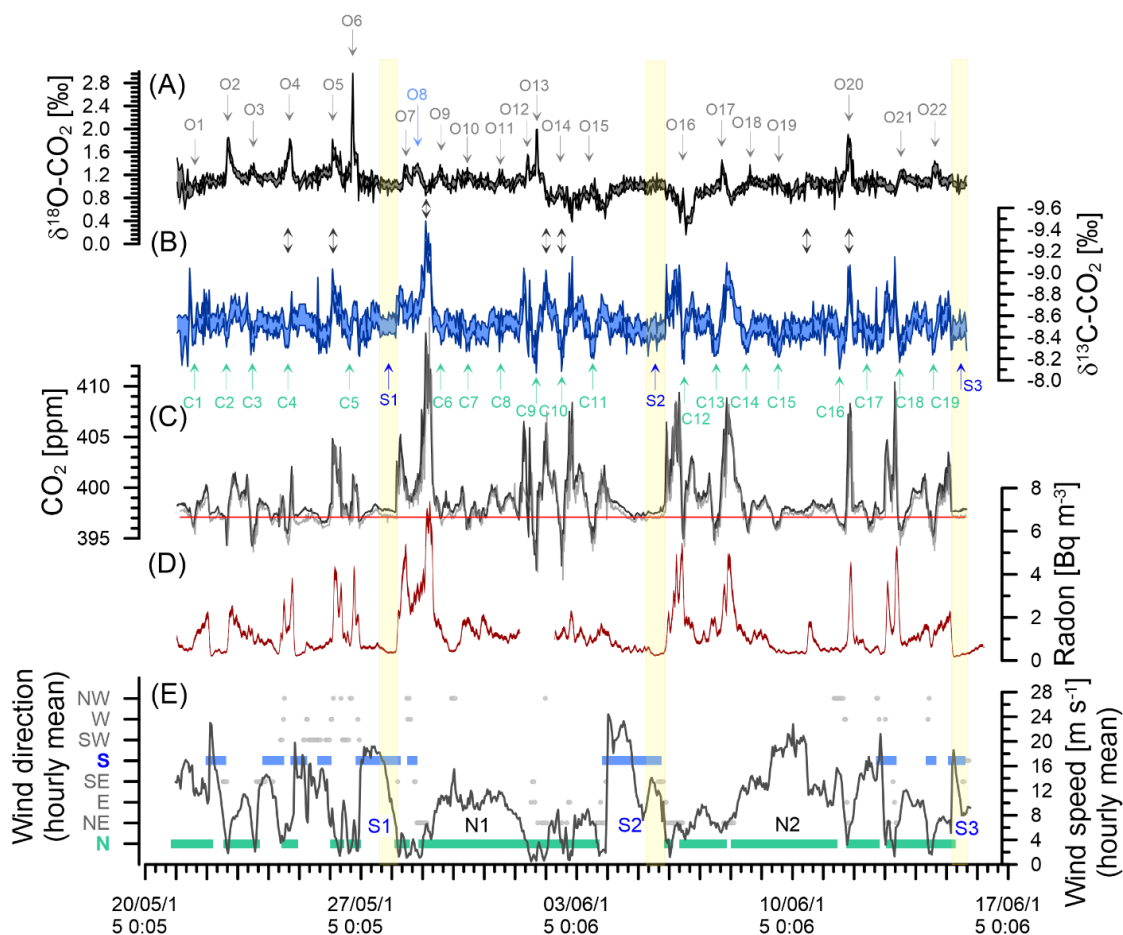

1180

1185

1190

**Figure 11:** Observations during the deployment at BHD. Delta Ray time series of  $\delta^{18}\text{O-CO}_2$  (A) and  $\delta^{13}\text{C-CO}_2$  with inverted y-axis (B).  $\text{CO}_2$  mole fractions measured with Delta Ray (black) and Siemens (grey) with average of the Siemens analyser for baseline  $\text{CO}_2$  measured during S2 indicated in red (C). Coloured shading in (A), (B) and (C) indicates the standard deviation of the measurement averages of the Delta Ray measurements. Events in the  $\delta^{18}\text{O-CO}_2$  and  $\delta^{13}\text{C-CO}_2$  time series are numbered from O1 to O22 and C1 to C19, respectively. (D) shows the Radon time series and (E) hourly averages of meteorological data. Southerly and northerly wind events are highlighted in blue and green, respectively. Wind speed is displayed by the black line. The yellow boxes highlight the most stable periods of the three significant southerly events S1, S2 and S3.

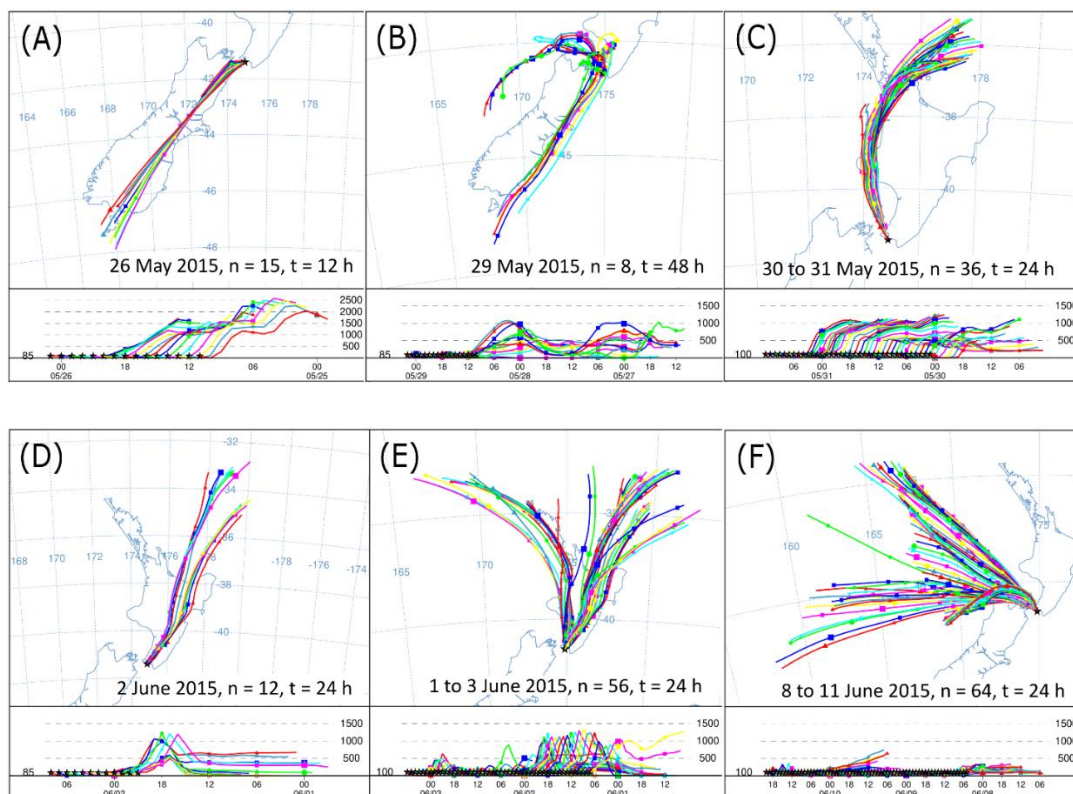

1195 **Figure 12: HYSPLIT back trajectories from six events in the Delta Ray time series. Each panel shows the history of air that was**  
**measured at the stated date. Intervals between trajectories are 1 h, n indicates the number of trajectories in the panel, t represents**  
**the trajectory length in hours.**

1200

1205

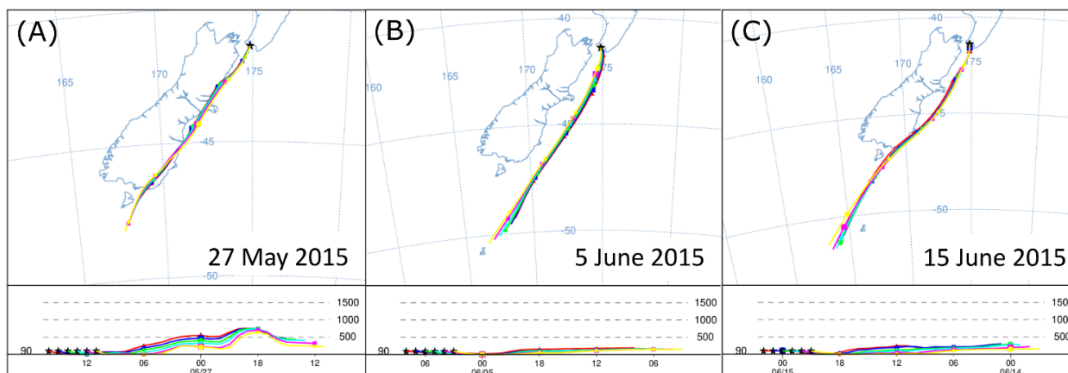

1210 **Figure 13: HYSPLIT back trajectories (24 h) for the air measured during S1, S2 and S3, with a 1 h interval between displayed trajectories. The selected timing is consistent with the final 6 h of each event displayed in Figure 17 with the lowest Radon counts.**

1215

1220

1225

1230

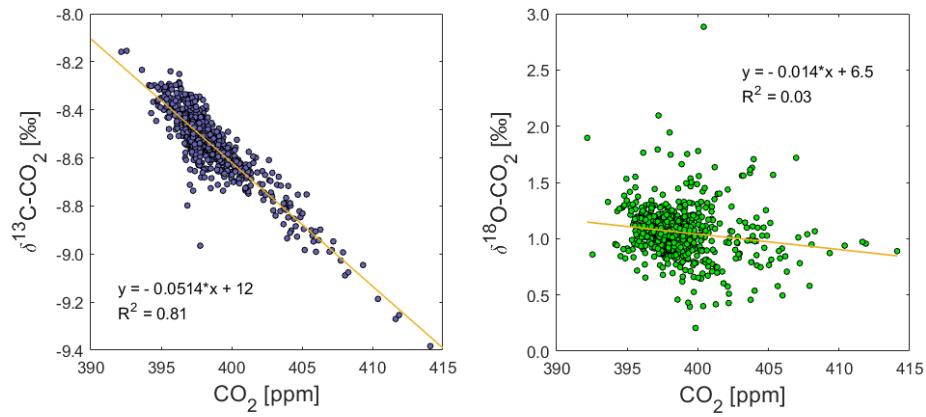

Figure 14: Correlation between CO<sub>2</sub> and δ<sup>13</sup>C-CO<sub>2</sub> (left) and δ<sup>18</sup>O-CO<sub>2</sub> (right) in air (n = 791).

1235

1240

1245

1250

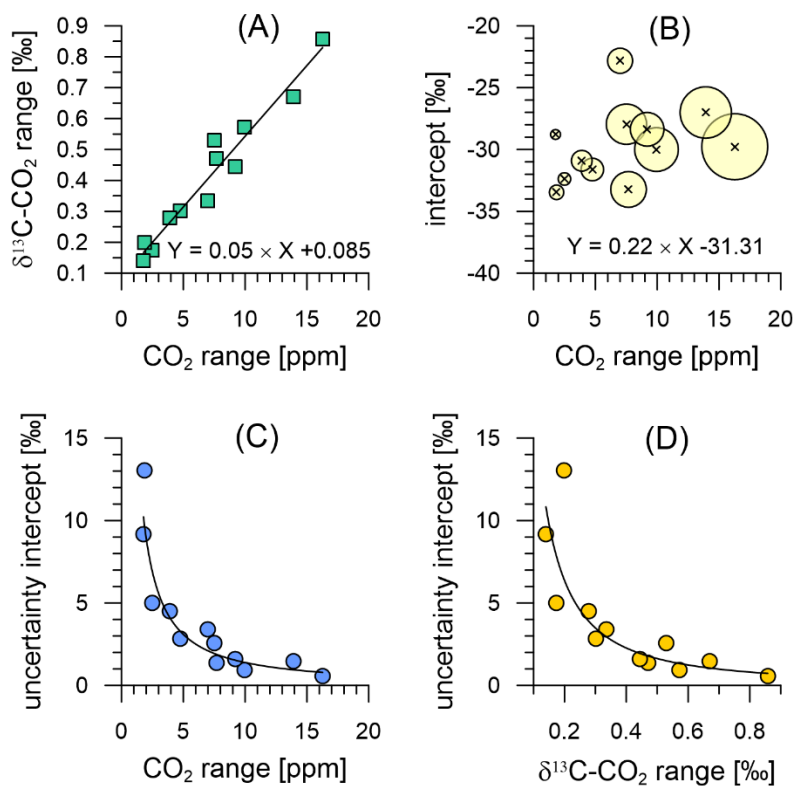

1255

**Figure 15: Relationship between the variations in  $\text{CO}_2$  and  $\delta^{13}\text{C-CO}_2$  of the twelve events used for KPA (A), as well as their intercept as function of the covered  $\text{CO}_2$  range (B). The bubble size in (B) scales with the range in  $\delta^{13}\text{C-CO}_2$  covered within the KPA event. Uncertainty of the intercept (standard error) as function of the range in  $\text{CO}_2$  (C) and  $\delta^{13}\text{C-CO}_2$  (D).**

1260

1265

1270



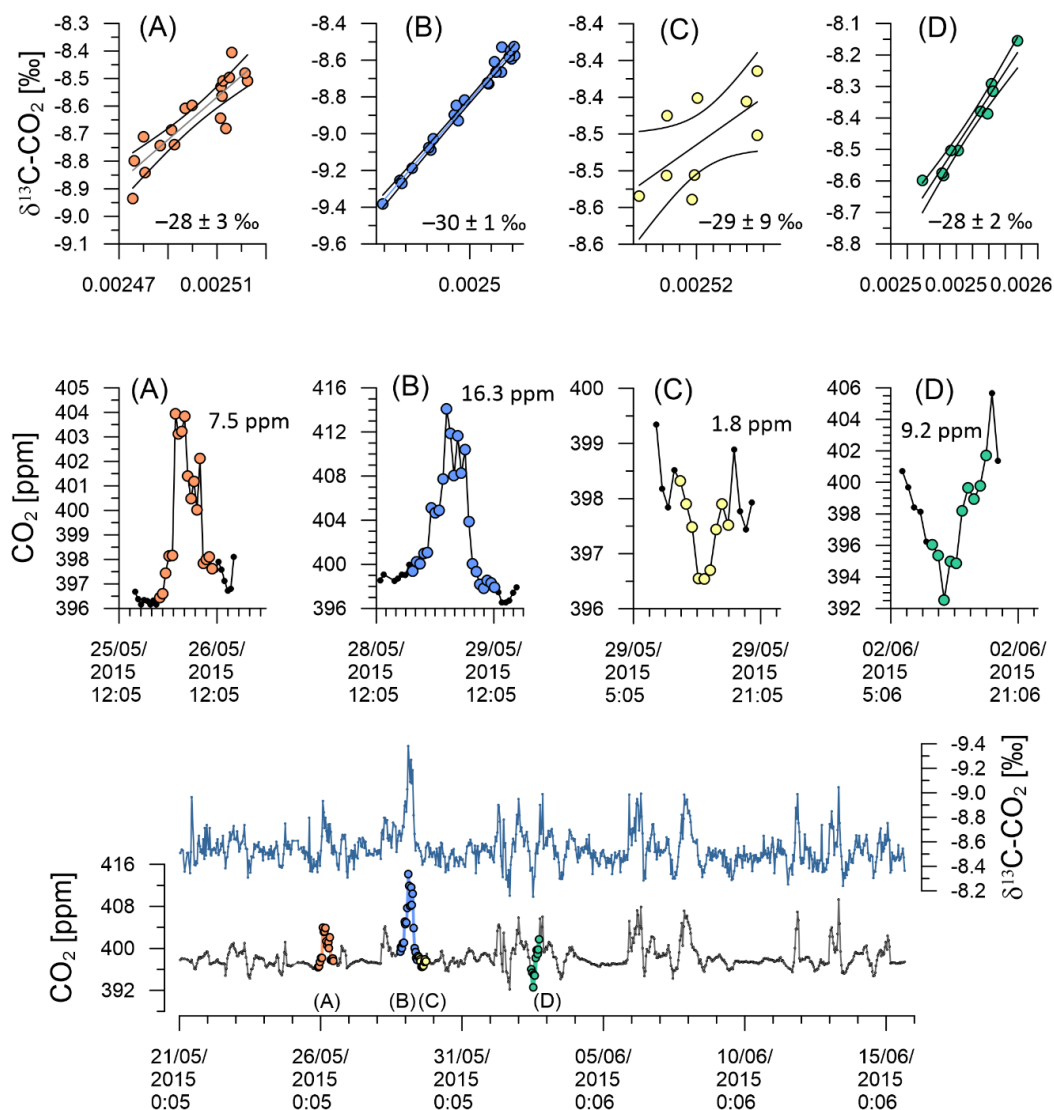

**Figure 16:** CO<sub>2</sub> and δ<sup>13</sup>C-CO<sub>2</sub> time series with selected events (A-D) shown in colours on the CO<sub>2</sub> time series (bottom panel). CO<sub>2</sub> variation of events A-D (middle panel). KPA with 95 % confidence interval and standard error for the intercept of A-D (top panel).

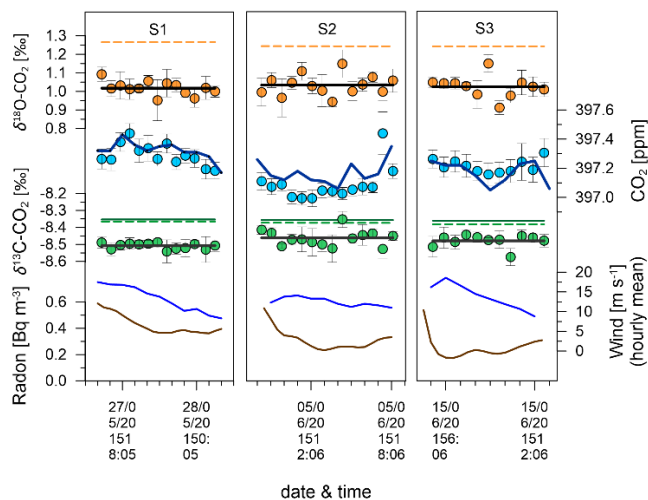

1280 **Figure 17: Data from southerly events S1 (left), S2 (middle) and S3 (right). Radon is shown in brown lines, mean hourly wind speed**  
1285 **in blue lines. Green, blue, and orange filled circles show average Delta Ray values for  $\delta^{13}\text{C-CO}_2$ ,  $\text{CO}_2$  mole fractions and  $\delta^{18}\text{O-CO}_2$ ,**  
**respectively. Error bars indicating the standard deviation ( $1\sigma$ ). Flat black lines indicate the event averages of the Delta Ray values**  
**for  $\delta^{13}\text{C-CO}_2$  and  $\delta^{18}\text{O-CO}_2$ . The dark green line shows the interpolated  $\delta^{13}\text{C-CO}_2$  value measured in flask samples before and after**  
**the test campaign, while dashed lines represent the interpolated values from  $\delta^{13}\text{C-CO}_2$  and  $\delta^{18}\text{O-CO}_2$  observations at Cape Grim**  
**observatory. The dark blue line shows the  $\text{CO}_2$  mole fraction values as interpolated from 5 min averages of the Siemens analyser at**  
**BHD.**

1290